

Rapid Steamer RS-1000 INTL Owner's Manual

Manufacturing Number:
9100651



Table of Contents

Overview	2
Before Use	2
In Case of Damage	2
Website	2
Service/Technical Assistance	2
Equipment Information to Save.....	2
Authorized Service Agency	2
Safety Information	3
Operation	3
Backflow Protection.....	3
Maintenance.....	3
Service	3
Specifications	4
Electrical Ratings	4
Installation	5
Unpacking	5
Equipment Setup.....	5
Touchscreen.....	5
Touchscreen Icons	5
Operating Instructions	6
Menu Items	7
Editing a Menu Item	7
Creating New Menu Items.....	7
Copying a Menu Item	7
Deleting a Menu Item	7
System Settings	8
Loading Menu Data	8
Maintenance	9
Daily Cleaning	9
Monthly Cleaning	10
Checking and Cleaning Strainer	10
Troubleshooting	11
Wiring Diagram	12
Replacement Parts List	13
Exploded Views	14
Exploded Diagram 1.....	14
Exploded Diagram 2.....	15
Exploded Diagram 3.....	16
Exploded Diagram 4.....	17
Exploded Diagram 5.....	18
Exploded Diagram 6.....	19
Limited Warranty	20

Overview

The Rapid Steamer features a touchscreen interface for quickly preparing items. This easy-to-use unit can handle a variety of different menu items without causing any delays in service. The included USB connection allows operations to easily load new recipes to handle new and expanding menus.

Before Use

This manual contains safety, installation, and operating procedures for the Rapid Steamer. Read and understand it completely before installing or operating the steamer. Keep this document for reference. If the steamer changes ownership, this manual must accompany it.

Immediately upon receipt, inspect the steamer for damage. Report any shipping damage or incorrect shipment to the delivery agent.

Record the model number, serial number, and installation date of your steamer and keep this information for future reference.

In Case of Damage

If the steamer arrives damaged, file a claim with the carrier immediately. Save all packing materials when filing a claim. Freight damage claims are the responsibility of the purchaser and are not covered under warranty.

Website

www.antunes.com

Service/Technical Assistance

If any parts are missing or damaged, contact Antunes Customer Service immediately at +1-877-392-7856 (toll free).

If there are problems with the installation or operation of this product, contact Antunes Technical Service toll free at +1-877-392-7854.

Fill in the information below and have it handy when calling for assistance. The serial number is on the specification plate located on the system.

Equipment Information to Save

Purchased from:

Date of purchase:

Model number:

Serial number:

Manufacturing number:

Authorized Service Agency

Name:

Phone No:

Address:

Safety Information

Operation

Use the following guidelines for safe operation of the steamer.

- Read all instructions before using equipment.
- For your safety, the equipment is furnished with a properly grounded cord connector. Do not attempt to defeat the grounded connector.
- Install or locate the equipment only for its intended use as described in this manual. Do not use corrosive chemicals in this equipment.
- Do not operate this equipment if it has a damaged cord or plug, if it is not working properly, or if it has been damaged or dropped.
- Do not block or cover any openings on the steamer.
- Do not immerse cord or plug in water.
- Keep cord away from heated surfaces.
- Do not use an extension cord with this device.
- Do not allow cord to hang over edge of table or counter.

NOTE: Turning off the power switch does NOT turn off all power to the steamer.

- The equipment should be grounded according to local electrical codes to prevent the possibility of electrical shock. It requires a grounded receptacle with separate electrical lines, protected by fuses or circuit breaker of the proper rating.
- All electrical connections must be in accordance with local electrical codes and any other applicable codes.

Backflow Protection

1001062	NORMAL OPERATING WATER PRESSURE	20 - 25 PSI 1.38 - 1.73 BAR
	THE EQUIPMENT IS TO BE INSTALLED TO COMPLY WITH THE BASIC PLUMBING CODE OF THE BUILDING OFFICIALS AND CODE ADMINISTRATORS INTERNATIONAL, INC. (BOCA) AND THE FOOD SERVICE SANITATION MANUAL OF THE FOOD AND DRUG ADMINISTRATION (FDA).	

The Rapid Steamer RS-1000 must be installed with adequate backflow protection to comply with applicable federal, state, and local codes.

Maintenance

- Do not use abrasive materials; they can damage the steamer's stainless steel finish.
- Do not use corrosive chemicals in this equipment.
- Chlorides or phosphates in cleaning agents (e.g., bleach, sanitizers, degreasers, and detergents) can permanently damage stainless steel equipment. The damage is usually in the form of discoloration, dulling of the metal surface finish, pits, voids, holes, or cracks. This damage is permanent and is not covered by warranty.
- Use only chemical cleaners that are safe for cast aluminum. Observe all precautions and warnings on product labels.
- Always use a soft, damp cloth for cleaning. Rinse with clear water and wipe dry. When required, always rub in the direction of metal polish lines.
- Routine cleaning should be performed daily with soap, ammonia detergent, and water.
- Sponge stains and hard water spots with a 50% vinegar solution.
- Rub off finger marks and smears using soap and water.
- Do not clean the steamer with a water jet.

Service

- Inspection, testing, and repair of electrical equipment must be performed only by qualified service personnel.
- Have the steamer serviced only by qualified personnel. Contact Antunes Technical Service for adjustment or repair.
- Turn the power off, unplug the power cord, and allow steamer to cool to room temperature before performing any service or maintenance.
- If the supply cord is damaged, it must be replaced by the manufacturer, its service agent, or a similarly qualified person in order to avoid an electrical hazard.

Specifications

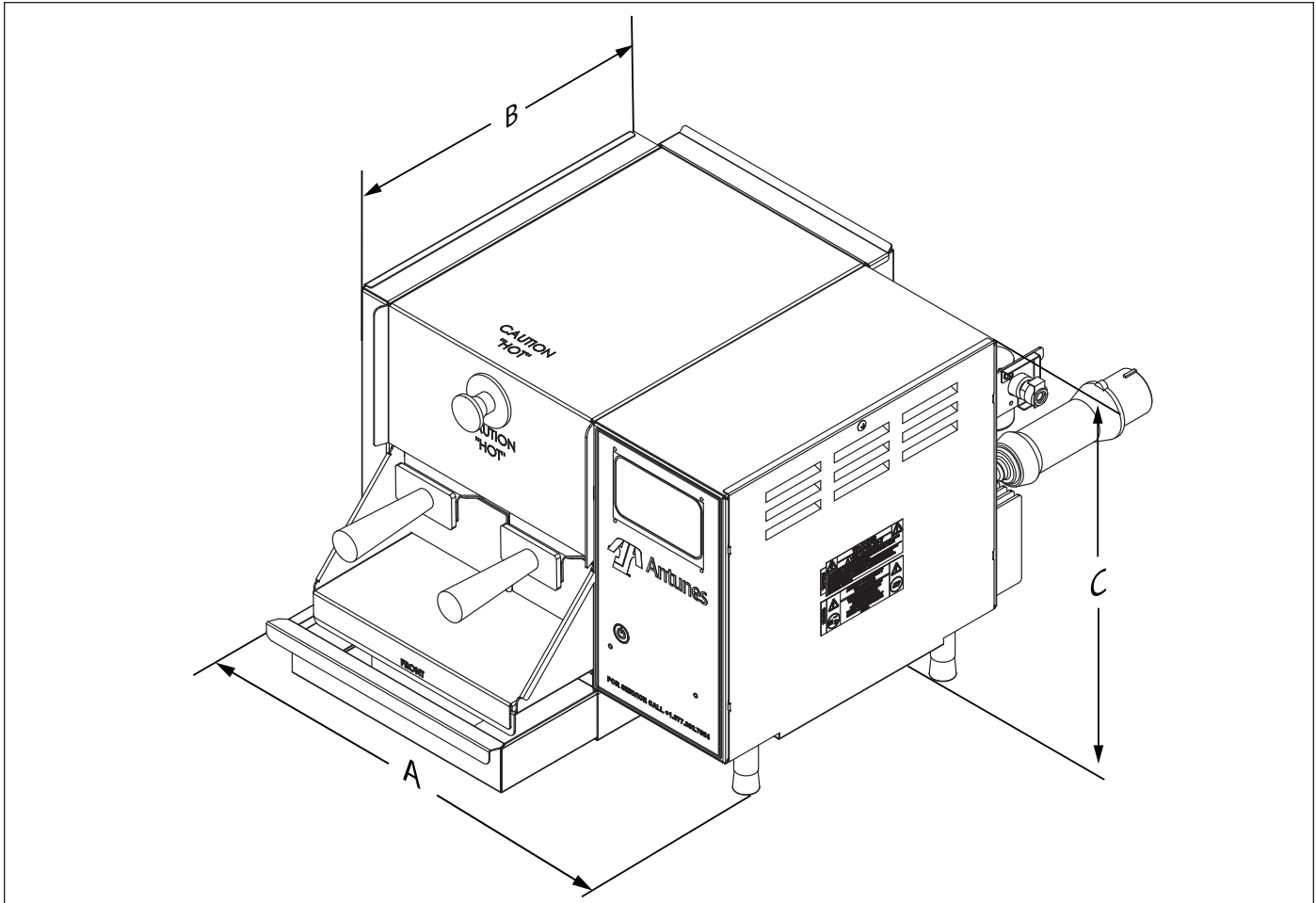

Electrical Ratings

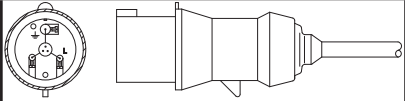
Mfg. No.	Volts	Watts	Amps	Hertz	Plug Description	Plug Configuration
9100651	200-240	5000	30	50/60	HRN/IEC309	

Mfg. No.	(A) Width	(B) Depth	(C) Height
9100651	17.39" (441.7mm)	16.86" (428.24mm)	12.79" (324.87mm)

Installation

Unpacking

1. Remove unit and all packing materials from shipping carton.
2. Open the large box. Remove all packing materials and protective coverings from the unit and parts.

NOTE: If any parts are missing or damaged, contact Antunes Customer Service IMMEDIATELY at +1-877-392-7856 (toll free).

3. Place the unit where it will be used.
4. Wash, rinse, and sanitize all components (Figure 1) at the sink. Wipe all surfaces of the unit with clean, sanitized towel.

NOTE: Do NOT use a dripping wet cloth. Wring out before use.

5. Install components in unit.
6. Connect the Flow Regulator to the cold water line.
7. Connect Inlet Hose Assembly.

Equipment Setup

When placing the unit into service, pay attention to the following guidelines.

- Install the steamer on an individual branch circuit only.
- Make sure power is off and the unit is at room temperature.
- Do NOT block or cover any openings on the unit.
- Do NOT immerse cord or plug in water.
- Keep cord away from heated surfaces.
- Do NOT allow cord to hang over edge of table or counter.
- Place unit on a sturdy, level table or work surface.
- Do NOT use an extension cord with the unit.
- Ensure that the line voltage corresponds to the voltage on the unit specification label.

Touchscreen

This unit is equipped with a touchscreen that uses a graphical user interface (GUI) that acts as the main control for the unit.

Treat the GUI interface with the same care as you would any touchscreen device. Do not use tools or objects on the GUI. Do not scratch or damage the GUI.

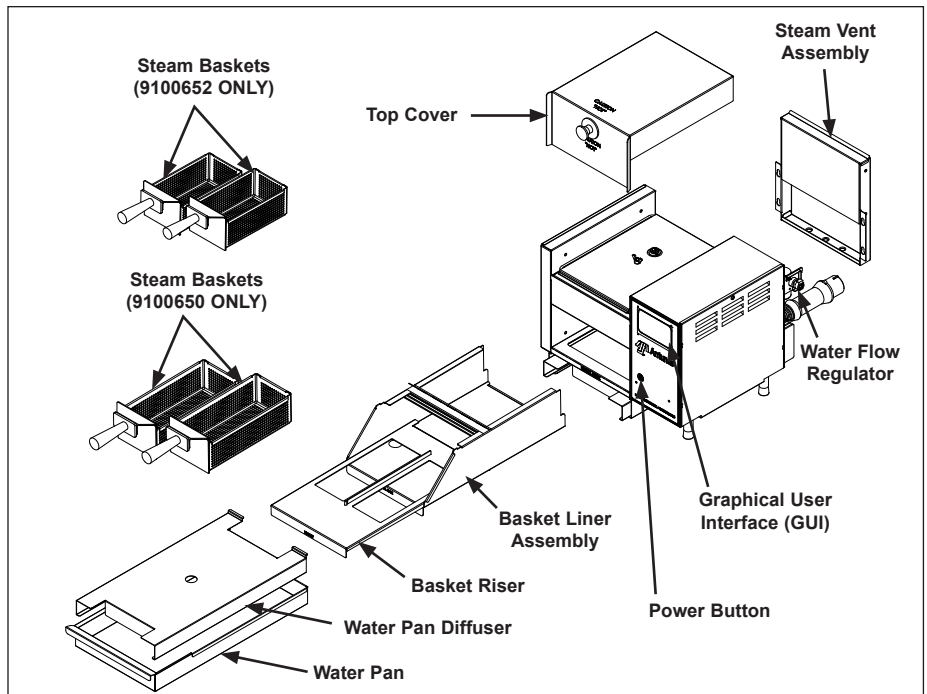
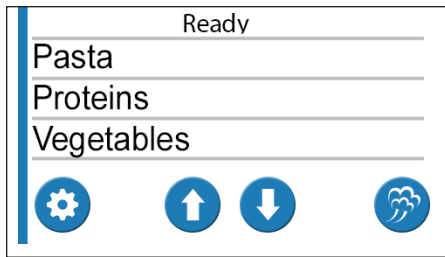

Figure 1. Components

Touchscreen Icons			
	Increase - Used to increase a value. Increments vary across items.		Menu - Used to access the menu editing, creation, copying, deleting, or factory reset section of the unit.
	Decrease - Used to decrease a value. Increments vary across items.		System Settings - Used to access and change system setting such as setpoint temperature, beep volume, and other settings.
	Save - Used to save data to the control board memory.		USB Update - Used to load menu information using the USB interface.
	Cancel - Used to cancel the current activity.		Edit Menu Item - Used to select a menu item to edit.
	Pause - Used to pause a cooking cycle.		New Menu Item - Used to create a new menu item.
	Resume - Used to resume a paused a cooking cycle.		Delete - Used to delete a menu item.
	Steam - Used to initiate a single unlimited steam shot. Used for refreshing a food item if required.		Copy Menu Item - Used to create a copy of an existing menu item. The copied menu item appears at the bottom of the menu item list. It is put in alphabetical order upon unit restart.
	Tools - Used to access the tools menu for programming or creating menu items and accessing other system information.		Factory Reset - Used to restore the unit to the original factory settings. This erases any edits or new items created.

Operating Instructions

1. Plug the power cord into the appropriate outlet. Press the power button to turn the unit on.
2. After displaying start up information, the display shows the following information:
Heating, Please Wait
XXX° F
 Where XXX represents the actual temperature of the unit. This increases as the unit warms up. The progress bar shows the progress of heating. The unit cannot be used to steam during this time, however you can access system tools by pressing the Tools .
3. When the unit reaches proper heat, it displays the **Ready** screen and the list of the first 3 menu items in alphabetical order.



4. Load the food product into the basket(s) and inset the basket(s) into the unit.
5. Use the **Up** and **Down** arrows (↑ or ↓) to page up or down to the appropriate choice and then press the name of that choice. If the food item you are cooking is already shown on the display, you can simply press it.
6. The unit begins the cooking cycle. The display shows the time remaining in the cooking cycle and beeps when cooking is complete.
7. Remove the basket(s) from the unit and continue with food preparation as required.
8. When cooking is complete the unit returns to the Ready screen.

If required, you can press **Pause** (⏸) to pause the cooking cycle. Press **Resume** (▶) to continue cooking.

If you need to cancel a cooking cycle, press **Cancel** (✕). The display returns to the ready screen.

Use **Steam** (🌀) to refresh an item with a single shot of steam.

NOTE: Do not remove the baskets during a cooking cycle.

NOTE: Depending on the cooking cycle, the unit may need to warm up after cooking. You cannot start a cooking cycle during warm up. It is normal to see the warm up screen after particularly long cook cycles.

WARNING

Keep face away from cover and opening when removing product from unit. Steam can escape and cause personal injury.

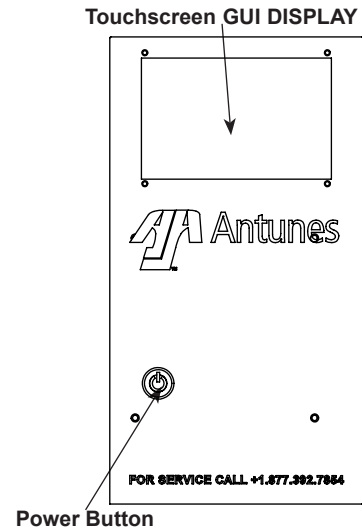
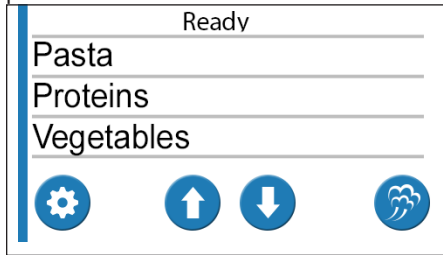

Figure 2. Control Panel

Menu Items

Follow these steps to create new menu items, edit existing menu items, delete menu items or copy menu items:

From the **Heating** or **Ready** screen, press **Tools** .



This opens the **Tools** screen shown below.

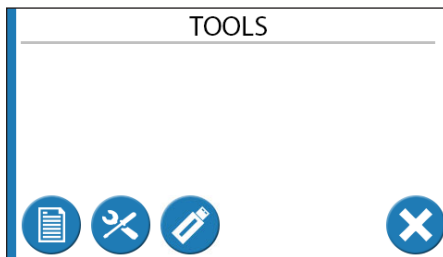

To work with menu items, press **Menu** . This opens the **Select Function** screen shown below.

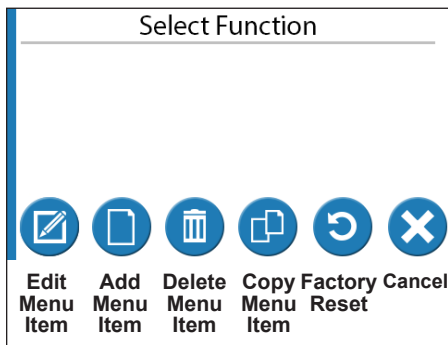

From the **Select Function** screen (above), press the appropriate icon to edit, add, delete, or copy a menu item. You can also press the Factory Reset icon to restore the factory settings or press the Cancel icon to return to the **Tools** screen.

Editing a Menu Item

If you press **Edit Menu Item** , the system displays a list of the existing menu items starting with the first three.

If the food item you want to edit is already shown on the display, you can simply press it.

After you touch the item you wish to edit, the system displays the name of the item and an on-screen keyboard you can use to rename the item. Edit the item name as desired or leave it as it is.

Press the **RETURN** button on the keyboard. The name is saved and the system then displays the **New Item** screen (below) with the available settings for the edited menu item.

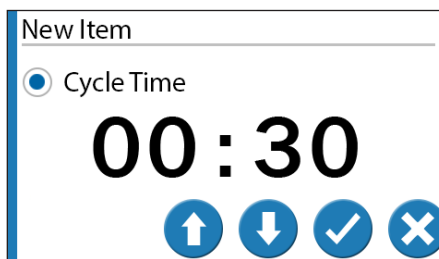

Be sure to change all values as required before proceeding. When you are finished making changes, press **Save**  to save the settings.

NOTE: You must press the radio button next to each setting before you can adjust it.

The available setting you can change is:

- **Cycle Time** - The length of time in minutes and seconds for the full cooking cycle.

You can also press **Cancel**  to cancel the edit and return to the **Select Function** screen.



Creating New Menu Items

Creating new menu items follows the same procedure as editing an existing menu item. The only difference is that you press **Add Menu Item**  from the **Select Function** screen. Then you are asked to enter a name for the new menu item. Do so and press the **RETURN** button on the on-screen keyboard.

The system then displays the **New Item** screen where you can set the Cycle Time just as you would when editing a menu item.

Copying a Menu Item

To copy a menu item, press **Copy Menu Item**  from the **Select Function** screen. The system displays a list of the existing menu items starting with the first three.

Use the **Up** and **Down** arrows ( or ) to page up or down to the appropriate choice and then press the name of that choice. The menu item is copied and added to the end of the menu item list.



You can then edit the name of the copied item and edit the settings according to the **Editing a Menu Item** section of this manual.

The new menu item will be put in alphabetical order upon unit restart.

Deleting a Menu Item

To delete a menu item, press **Delete**  from the **Select Function** screen. The system shows the list of existing menu items in alphabetical order.

NOTE: Be sure you want to delete the menu item before proceeding!

Use the **Up** and **Down** arrows ( or ) to page up or down to the appropriate choice and then press the name of that choice. The menu item is deleted.

System Settings

Follow these steps to access and edit the system settings.

1. From the **Heating** or **Ready** screen, press **Tools** .

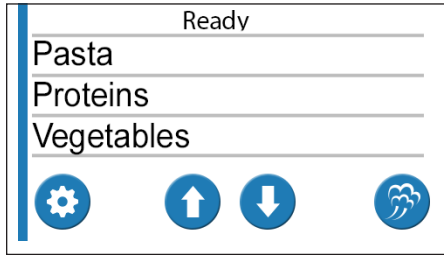

2. This opens the **Tools** screen shown below.

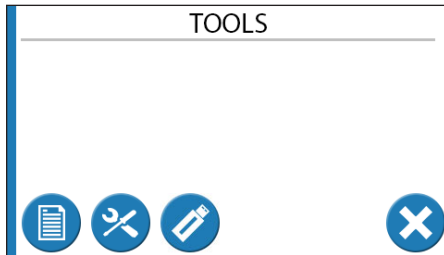

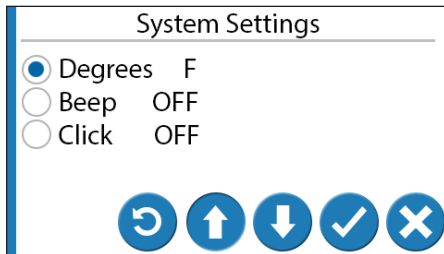

3. To work with settings items, press **System Settings** . This opens the **System Settings** screen shown below.



4. From this screen you can change the following system settings:
 - **Degrees:** F or C.
 - **Beep** (sounds when cooking cycle completes). Options are: HI, LO, and OFF.
 - **Click** (the sound that accompanies each screen press). Options are: HI, LO, and OFF.

NOTE: You must press the radio button next to each setting before you can adjust it.

5. Once you have changed the System settings as desired, press **Save** . The system saves the changes to memory.

To cancel your changes, press **Cancel**  to return to the **Tools** screen.



Loading Menu Data

The unit is equipped with a USB interface on the back of the unit. This allows you to load menu items into the system. To load a menu file:

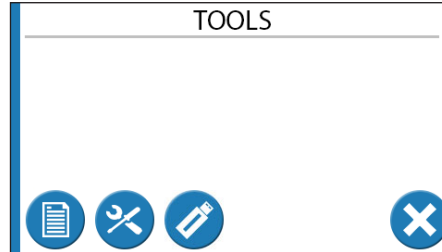
Make sure the unit displays the **Ready** or **Heating** screen. Insert the USB memory stick loaded with the electronic menu file into the USB connection (Figure 3).



1. Press **Tools** to open the Tools screen.
2. Press **USB Import** . The system reads the USB device and displays a list of acceptable menu files on the **USB Import** screen.

3. Use the **Up** and **Down** arrows ( or ) to locate the proper file name.

NOTE: The system displays one file name at a time. Be sure to scroll through the choices to find the appropriate file.

4. When the proper file name appears on the screen, press  to begin loading the file into the system.

When the import is complete, the system displays:

Copy Completed Remove USB, Press OK

5. Remove the USB stick and press . The system returns to the **Tools** Screen. You can verify the import by going back to the **Ready** screen by pressing the cancel button.

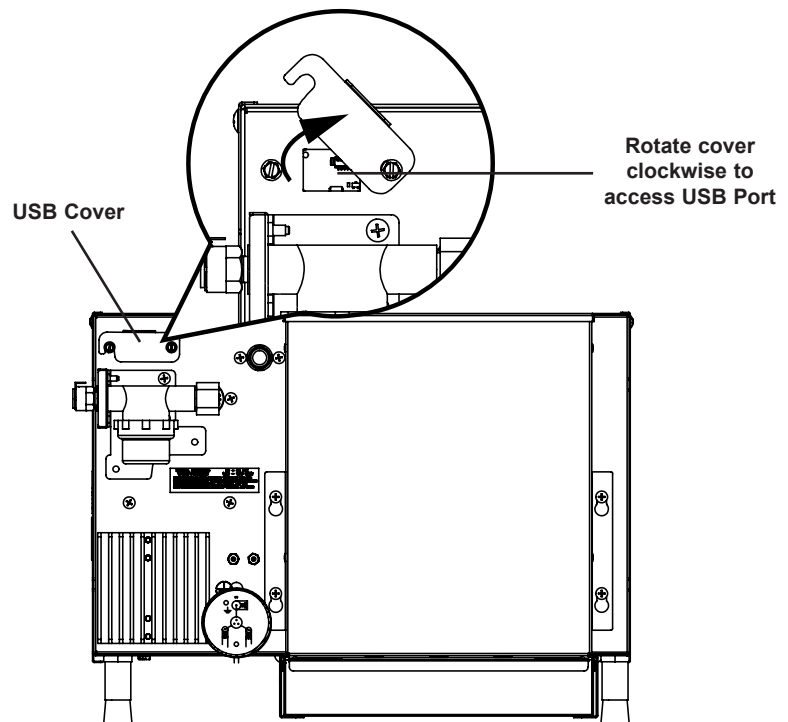

Figure 3. USB Port

Maintenance

NOTE: Frequency of cleaning is determined by water conditions, usage and water filter systems. Recommended water hardness, or Total Dissolved Solids (TDS), should not exceed 60 ppm (parts per million)

Daily Cleaning

1. Press the Power button to turn the unit off. The unit enters a cool-down mode and will shut down automatically.

NOTE: You do not need to wait until the cool down mode completes. However, the unit will be hot so wear heat resistant gloves during cleaning.

2. Put on heat resistant gloves and remove the items in Figure 4.
3. Wash, rinse, and sanitize the items removed at the sink. Allow to air dry.
4. Wipe the exterior of the unit and the inner part of the basket cavity with a clean, sanitized towel. Clean up any spills completely. Allow to air dry.
5. Reassemble the unit.

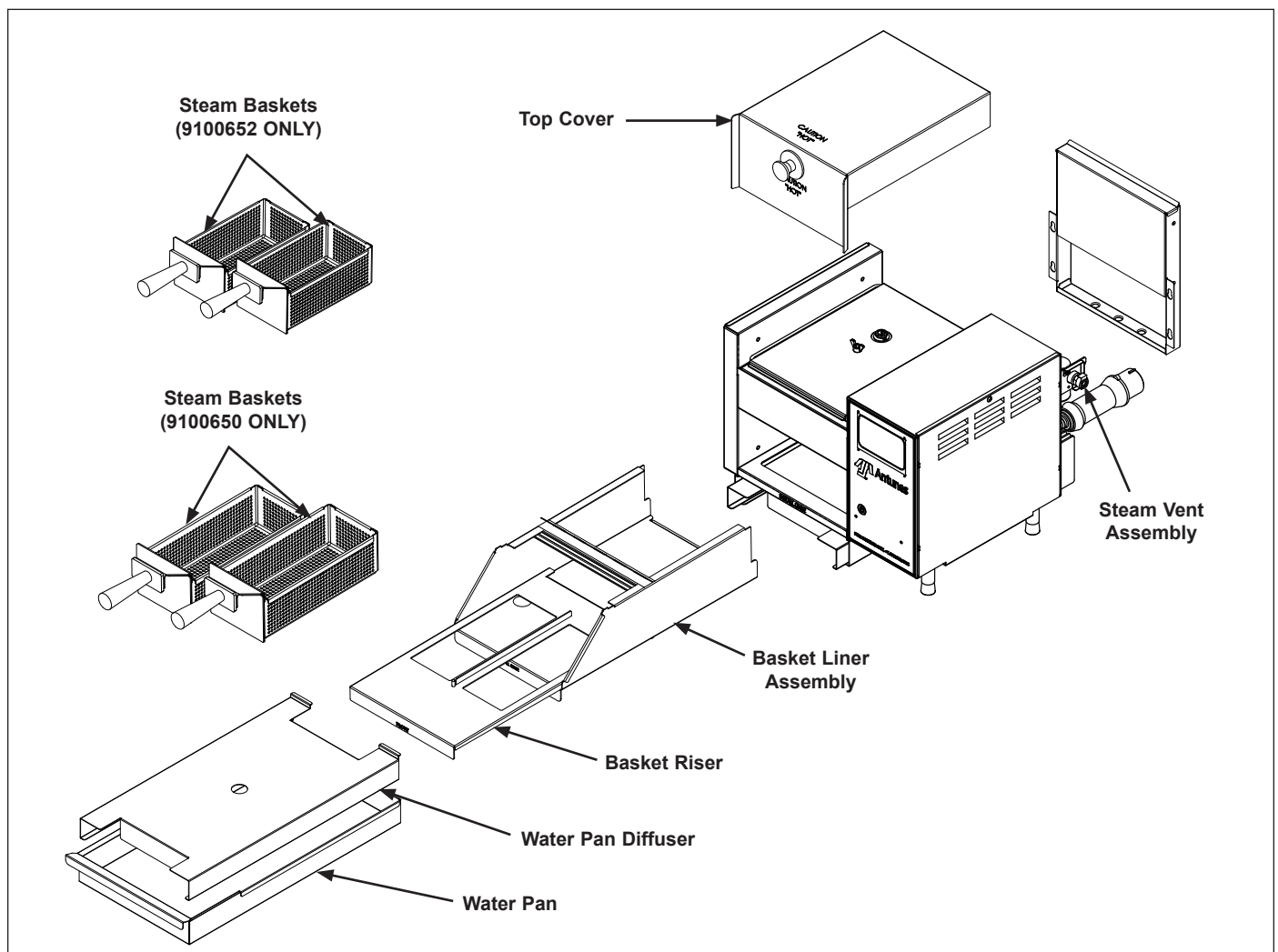

Figure 4. Components

Monthly Cleaning

This unit utilizes an open steam generator. When introduced, water immediately vaporizes creating a burst of steam, leaving behind any minerals that had previously been dissolved. Though a small amount of minerals are necessary for proper operation, excessive amounts will cause poor steaming and may damage the generator.

1. Press the Power button to turn the unit off. The unit enters a cool-down mode and will shut down automatically.

NOTE: You do not need to wait until the cool down mode completes. However, the unit will be hot so wear heat resistant gloves during cleaning.

2. Put on heat resistant gloves and remove the items in Figure 4.
3. Wash, rinse, and sanitize the items removed at the sink. Allow to air dry.
4. Wipe the exterior of the unit and the inner part of the basket cavity with a clean, sanitized towel. Clean up any spills completely. Allow to air dry.
5. Remove wing nut and generator cover assembly, generator gasket, and diffusers (Figure 5).
6. Examine all steam generator orifices (holes). If mineral deposits have formed, place a flat blade screwdriver into openings. Use a twisting motion to scrape openings clean.

NOTE: Mineral deposits come off in “flakes” or in layers if the build-up is excessive.

7. Use an abrasive cleaning brush and small scraper to remove deposits from the generator surface.
8. Pour delimer solution (not supplied) onto the generator surface and allow to soak for one hour.

NOTE: Be sure to Follow the usage instructions on the delimer packet.

9. Remove the delimer solution from the generator and rinse with clear water to remove traces of delimer.

NOTE: To ensure proper steaming characteristics some mineral deposits must be present on generator casting. If during cleaning, the generator does become free of mineral deposits, add ordinary tap water (non reverse osmosis or ionic filter system) to casting and allow to boil off.

NOTE: In soft water areas, it may be necessary to add a small amount of baking soda to generator to “season” it. This will ensure proper steaming characteristics by producing a thin coating of mineral deposits on the casting.

Seasoning mixture consists of 75 ml. (2-1/4 oz.) baking soda and 1 gallon water. Pour 1/4” deep of seasoning mixture into a cold generator. Turn the unit on. After mixture is converted to steam, the remaining loose powder is removed and generator cleaned.

10. Wipe the exterior of the unit and the inner part of the basket cavity with a clean, sanitized towel. Allow to air dry.
11. Re-install the diffusers, generator cover, generator cover bracket and secure with the wing nut.
12. Re-install all items removed in Step 2.

Checking and Cleaning Water Strainer

To ensure proper and consistent steaming results, inspect the water flow regulator and strainer cup regularly. If the water pressure on the gauge has dropped, visually check the clear plastic strainer cup and clean out the accumulated debris as follows:

1. Shut off the water supply valve to the unit. Unscrew the clear plastic strainer cup and carefully remove the mesh strainer screen.
2. At the sink, gently flush all of the accumulated debris from the strainer cup and mesh strainer screen. Be especially careful not to damage the mesh strainer screen.
3. Carefully place the mesh strainer screen into its seat at the bottom of the clear plastic cup and confirm that the O-ring is properly seated in its place before screwing the strainer cup and top back together.
4. Purge the air out of the strainer tubing by disconnecting the male quick disconnect fitting from the equipment and, over a bucket, pushing its valve core in until there is a good water flow.

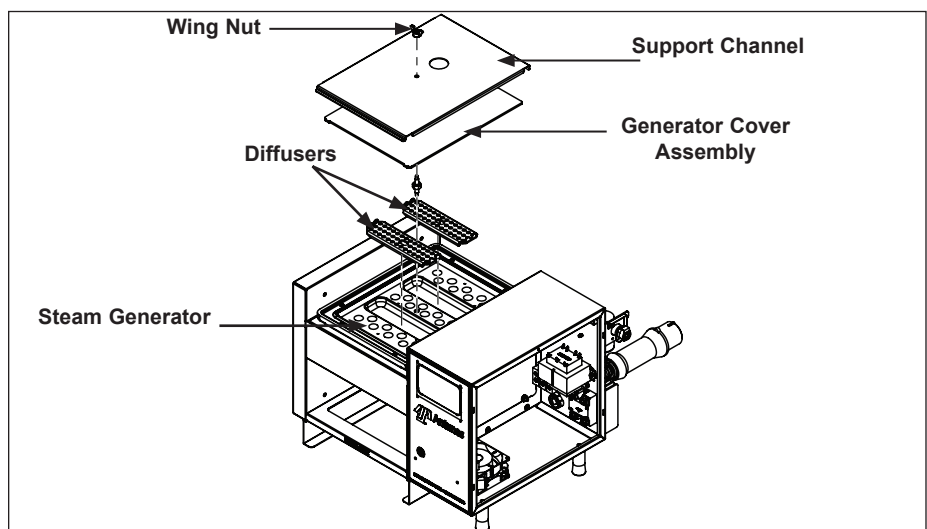

Figure 5. Steam Generator

Troubleshooting

Problem	Possible Cause	Corrective Action
Unit displays system error: "Zero Cross"	Power cord not correctly plugged in	Plug in the power cord correctly.
	The power cord and/or electrical plug is damaged	Inspect electrical wire, plug, and receptacle.
	Control board is inoperable	Contact your maintenance person or Authorized Service Agency for service.
	Transformer is inoperable	
Unit displays system error: "Warmup Timeout" because unit didn't warmup to desired temperature within 20 minutes.	Heat relay is inoperable	Contact your maintenance person or Authorized Service Agency for service.
	Heating element burnt out	
	Thermocouple is inoperable	
	Loose or burnt wiring in heating circuit	
Unit displays system error: "High Temp"	Hi-limit switch is tripped	Let the unit cool down. The hi-limit switch will clear itself once the unit drops below 500 °F and the unit will be operational again. If the hi-limit switch requires continuous resetting, contact your maintenance person or Authorized Service Agency for service.
Unit displays system error: "Open Probe TC1"	Open in thermocouple wiring	Contact your maintenance person or Authorized Service Agency for service.
	Loose or burnt wiring in thermocouple connection	
Unit displays system error: "FRAM"	Control board is inoperable	Reset the unit. If the problem persists, contact your maintenance person or Authorized Service Agency for service.
Unit displays system error: "Database Failure"	Possible data corruption on the receipts	Do a factory reset from the Menu Items menu to reset stored receipts. Reenter any missing receipts.
Unit heats but little or no steam is produced and/or the product requires more steaming than usual.	Water line valve is closed	Verify that the water line valve is open.
	Strainer is restricted	Check and clean the strainer as described in the Maintenance section of this manual.
	Quick disconnect is not fully engaged at rear of the unit or is damaged	Remove and reengage the quick disconnect firmly until a "click" is heard. Replace it if it is damaged.
	Low or no water pressure in water line	Remove the quick disconnect. Insert from the rear of the unit. While holding into an empty cup, press the white plastic tip. Strong steady water flow should be noted. If so, re-engage firmly into unit. If not present, or pressure is low, contact your maintenance person or plumber.
	Unit is not being cleaned daily or properly	Clean unit daily as described in the maintenance section of this manual.
	Insufficient or excessive calcium/mineral buildup on generator surface	Verify that a thin layer of deposits is present on the generator surface. Refer to the maintenance section of this manual.

Wiring Diagram

WIRING DIAGRAM WIRE LEGEND

⊕ 26 AWG MIL-W-16878/1 TYPE B

12 PVC ■

14 TEF ○

14 PV △

Ⓢ WIRE NUMBER

* 22 GA PVC

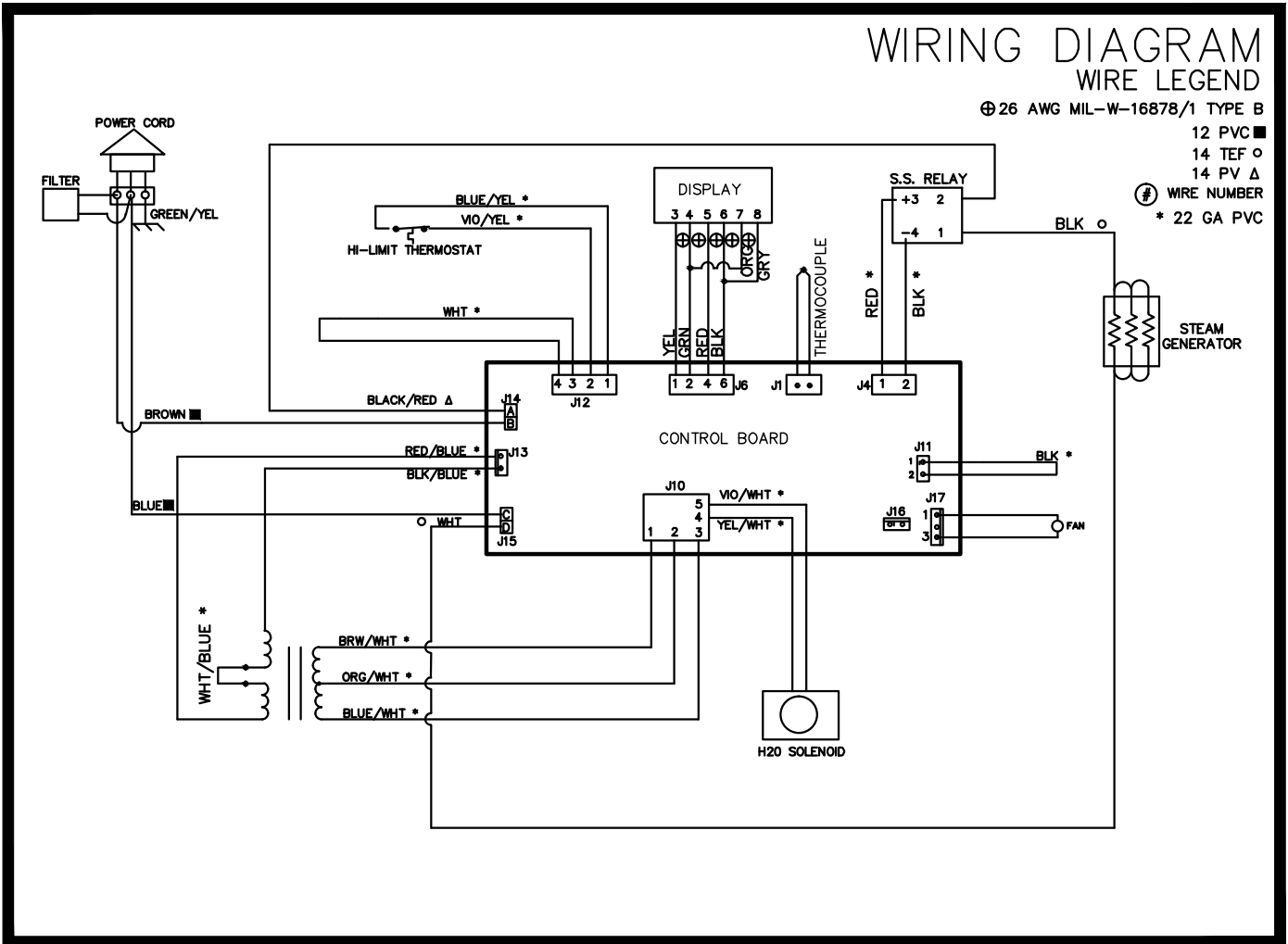

Replacement Parts List

Item No.	Part #	Description	Qty.
1	0011370	Leg Assembly - 2"	4
2	7002231	Top Cover Kit	1
3	7001927	Solenoid Valve Assy Kit	1
4	7002229	Double Basket Kit	2
5	7002227	Basket Liner Kit	1
6	7001920	Generator Kit (Includes #16)	1
7	7001921	Generator Cover Assy Kit	1
8	0013810	USB Bracket Assy	1
9	7001143	Relay Kit	1
10	7001926	Flow Regulator Assy Kit	1
11	7002228	Steam Vent Kit	1
12	0022280	Gasket Plate Weldmt	2
13	7002226	Basket Riser Kit	1
14	0022983	Weldmt, Chassis	1
15	0200360	Gasket Control Housing	2
16	0300129	Stud, Cover Hold Down	1
17	7002232	Generator Insulation Kit	1
18	0400514	Strain Relief Cable Gland	1
19	0502199	Spacer	4
20	0507194	Cover, USB	1
21	7002224	Water Pan Diffuser Kit	2
22	0507439	Support, Generator - Upper	1
23		Water Pan Kit	1
24	0507451	Panel, Electrical	2
25	0507462	Bracket, Mount Hi-Limit	1
27	7002230	Support Channel Kit	1
28	0509218	Plate, Locking	1
29	0509219	Bracket, Flow Regulator	1
30	7001724	Power Cord HRN/IEC309	1
31	0701062	Wire Set, RS-1000	1
32	1000900	Label, Service Warning	1
33	1001062	Label, Water and Waste Conn.	1
34	1001213	Label, Shock Hazard	1
35	1002726	Label, Control Panel	1
36	1002778	Label, Wiring Diagram	1

Item No.	Part #	Description	Qty.
37	1031402	Spec Label, 9100651	1
38	2120276	Spacer,k 3/16 OD x 5/32	4
39	2140101	Adhesive/Sealant - RTV	1
40	2140144	Tape, Pipe Thread	2
41	2180514	Clamp, Cable - Polypropylene	1
42	2190240	Pipe, PTFE	2
43	3000102	Nut, Speed #8/32 "U"	2
44	3000104	Tubular 1/8" Clip	1
45	3020132	Nut, Jam, #2-56 w/ Nylon Insert	4
46	3040105	Nut, Hex 'KEPS' #4-40 Zinc	4
47	3060130	Nut, Hex 'KEPS' #06-32 Steel; Zinc Plated	1
48	3060140	Scr, Mach. #6-32 x 1-1/4"	8
49	3080124	Scr, Mach. #8-32 x 1/2, 1-WAYHD	1
50	3080143	Nut, Hex 'KEPS' #8-32	2
51	3080145	Nut, Hex Acron #08-32 Low Crown	2
52	3080157	Screw, Tap 8-32 x 3/8" LG	16
53	3080193	Scr, Mach. #8-32 x 1 1/4" SLTFTHD	2
54	3080227	Scr, Mach. #8-32 x 3/8 HXHD SLTD; Shoulder S/S	3
55	3100146	Nut, Hex "KEPS" #10-32	8
56	3100178	Screw, Hex Bolt #10-32 x 3/8"	4
57	3250170	Nut, Wing 1/4"-20	1
58	7001440	Fan, Axial -230V, Metal Housing & Imp	1
59	7000319	Transformer, 115-230V/24V	1
60	7000272	Thermostat, Hi-Limit	1
61	7001919	Thermocouple, 6"	1
62	7001609	Terminal Block, S-Series	1
63	7001897	ASY-PCB, Display Board	1
64	7001940	Control Board	1
65	0014018	Assembly Capacitor	1
66	0012180	Inlet Hose Assembly	1
67	7002109	RS-100 Upgrade Kit	1

Exploded Views

Exploded Diagram 1

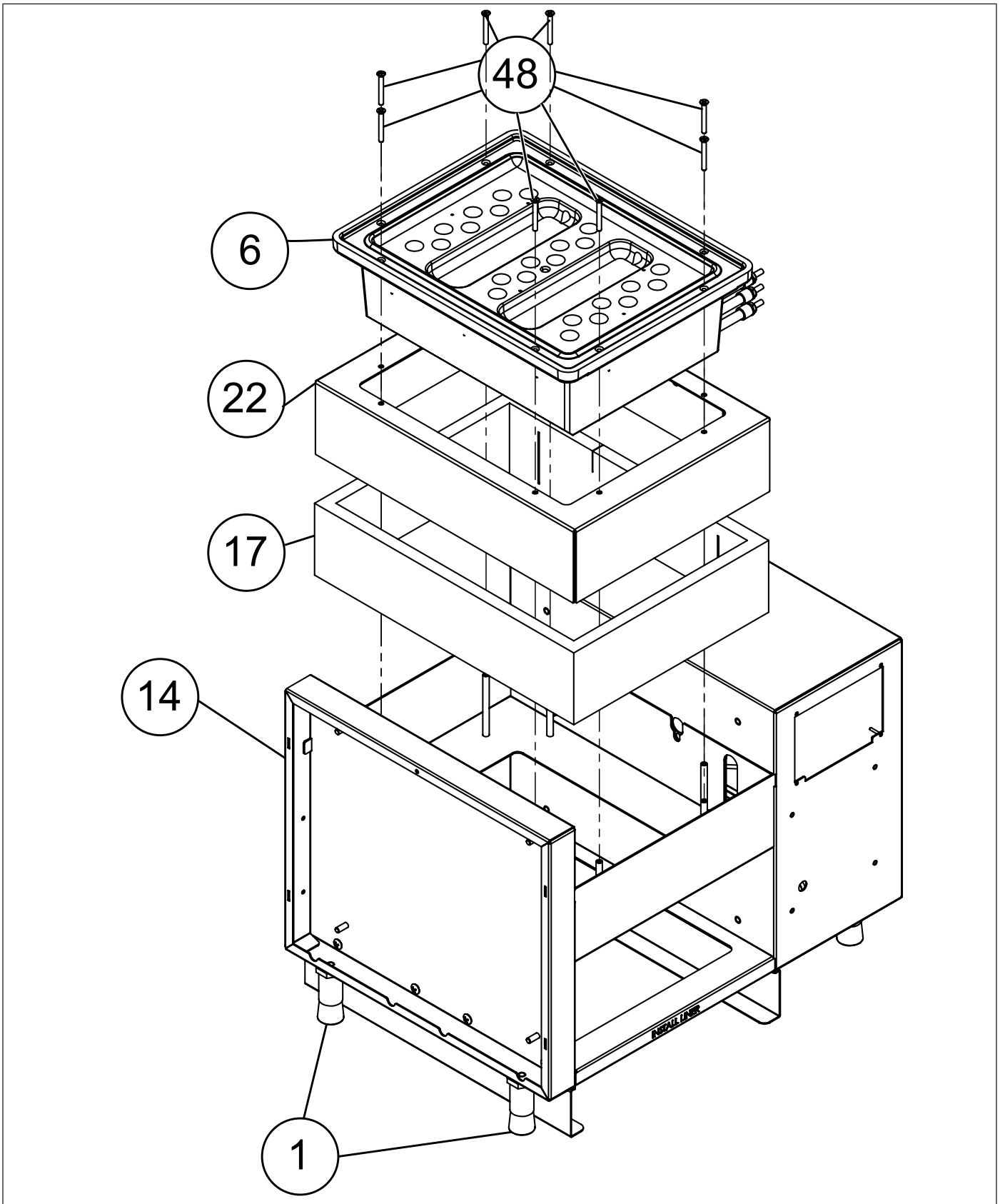

Exploded Views

Exploded Diagram 2

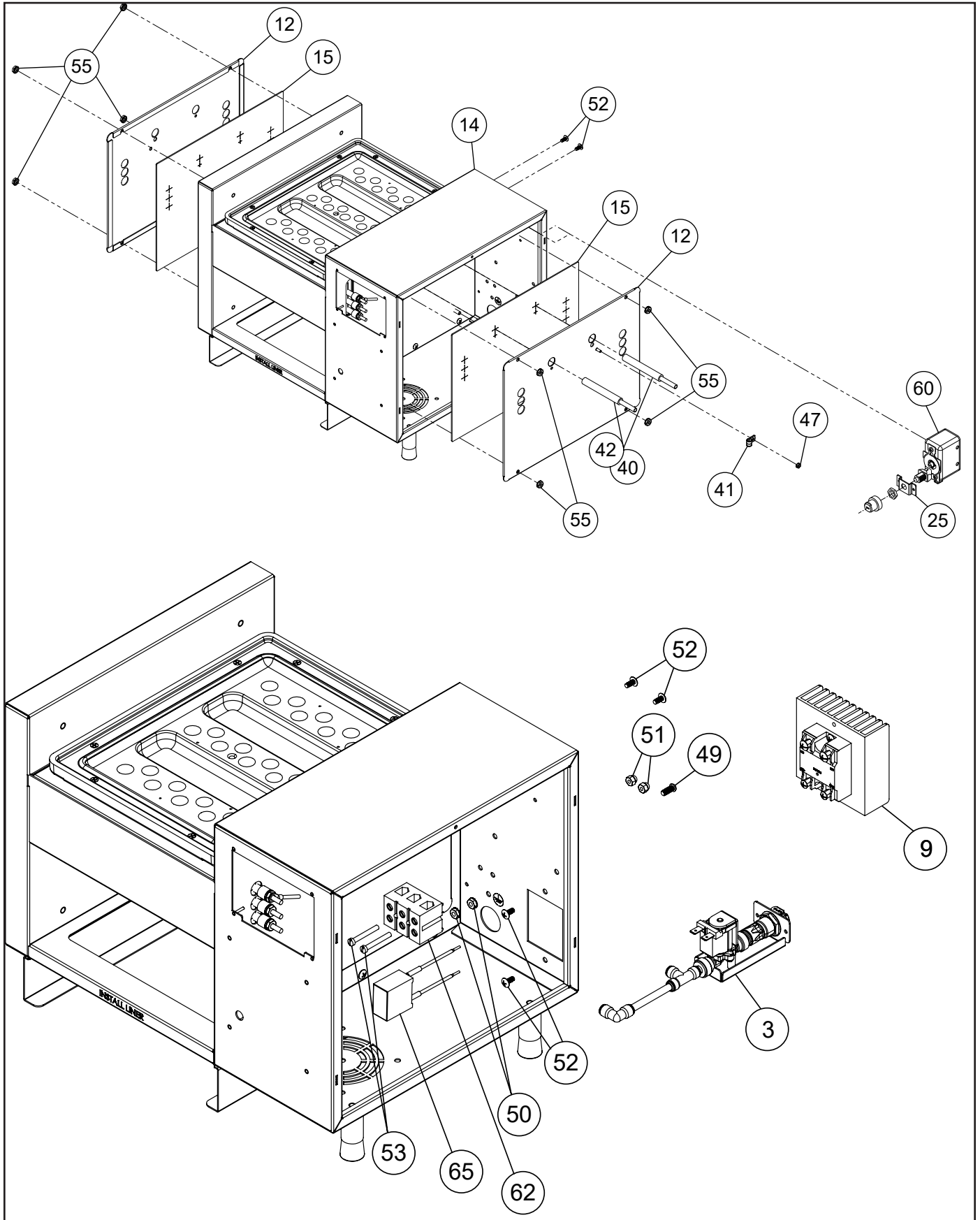

Exploded Views

Exploded Diagram 3

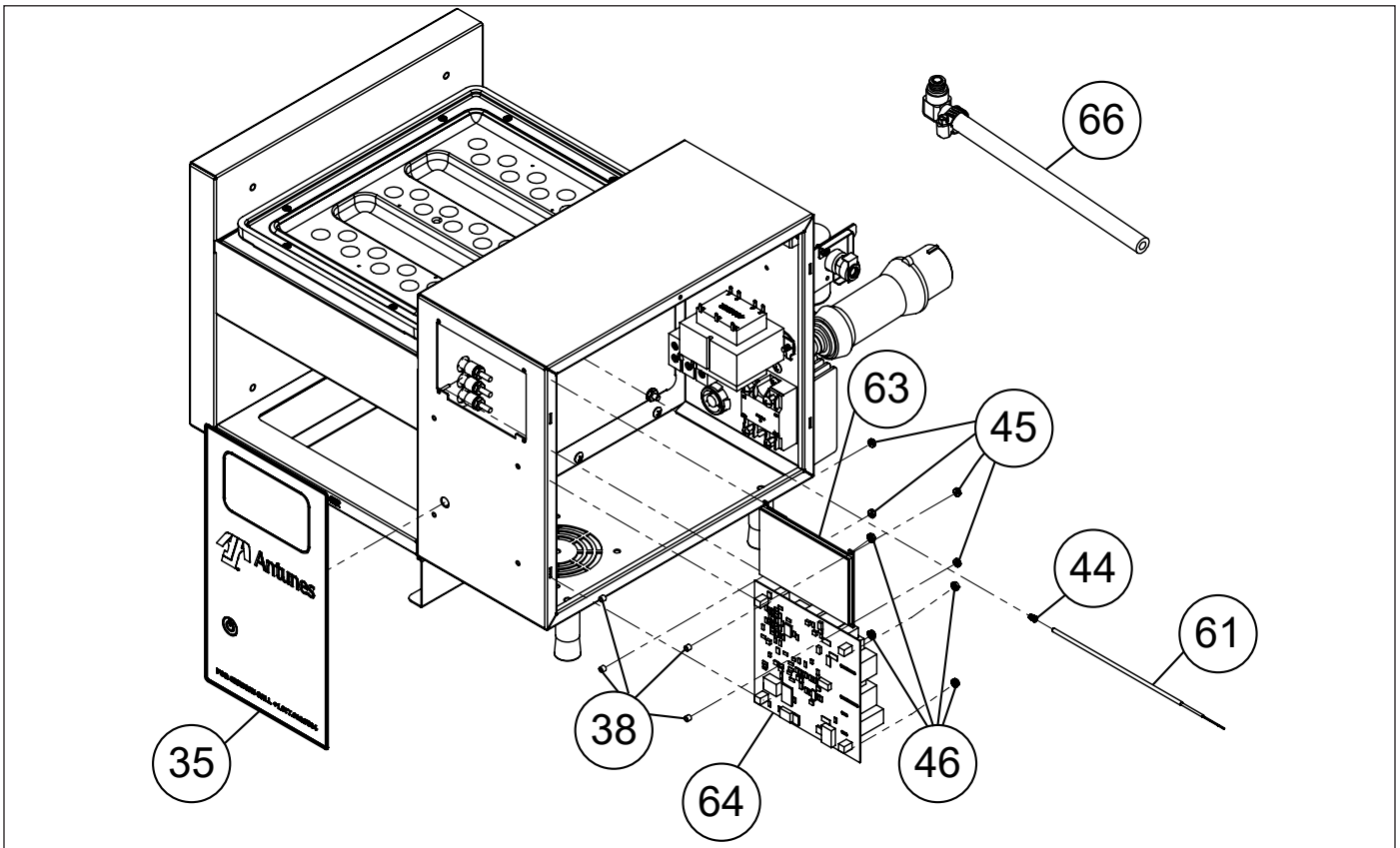
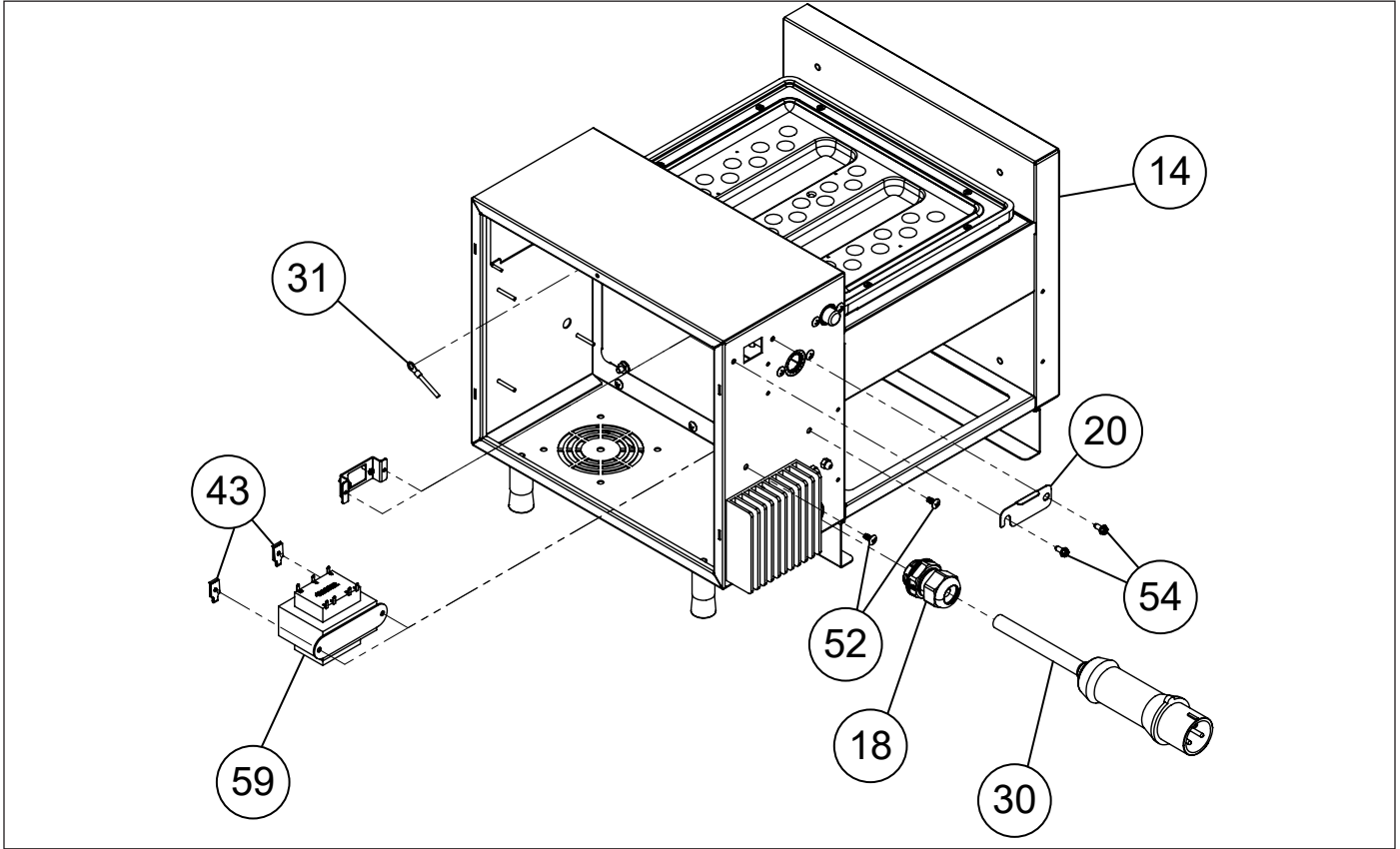

Exploded Views

Exploded Diagram 4

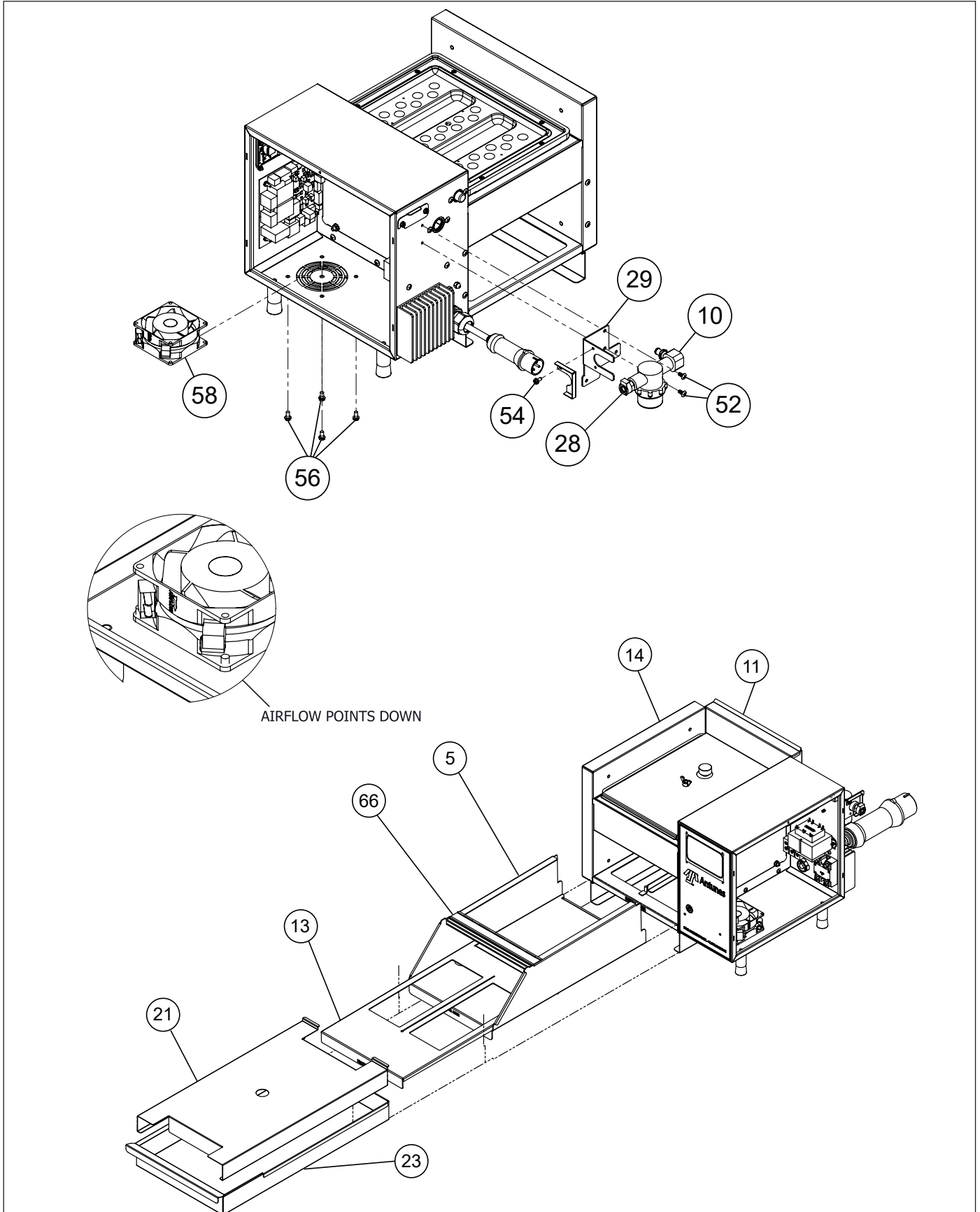

Exploded Views

Exploded Diagram 5

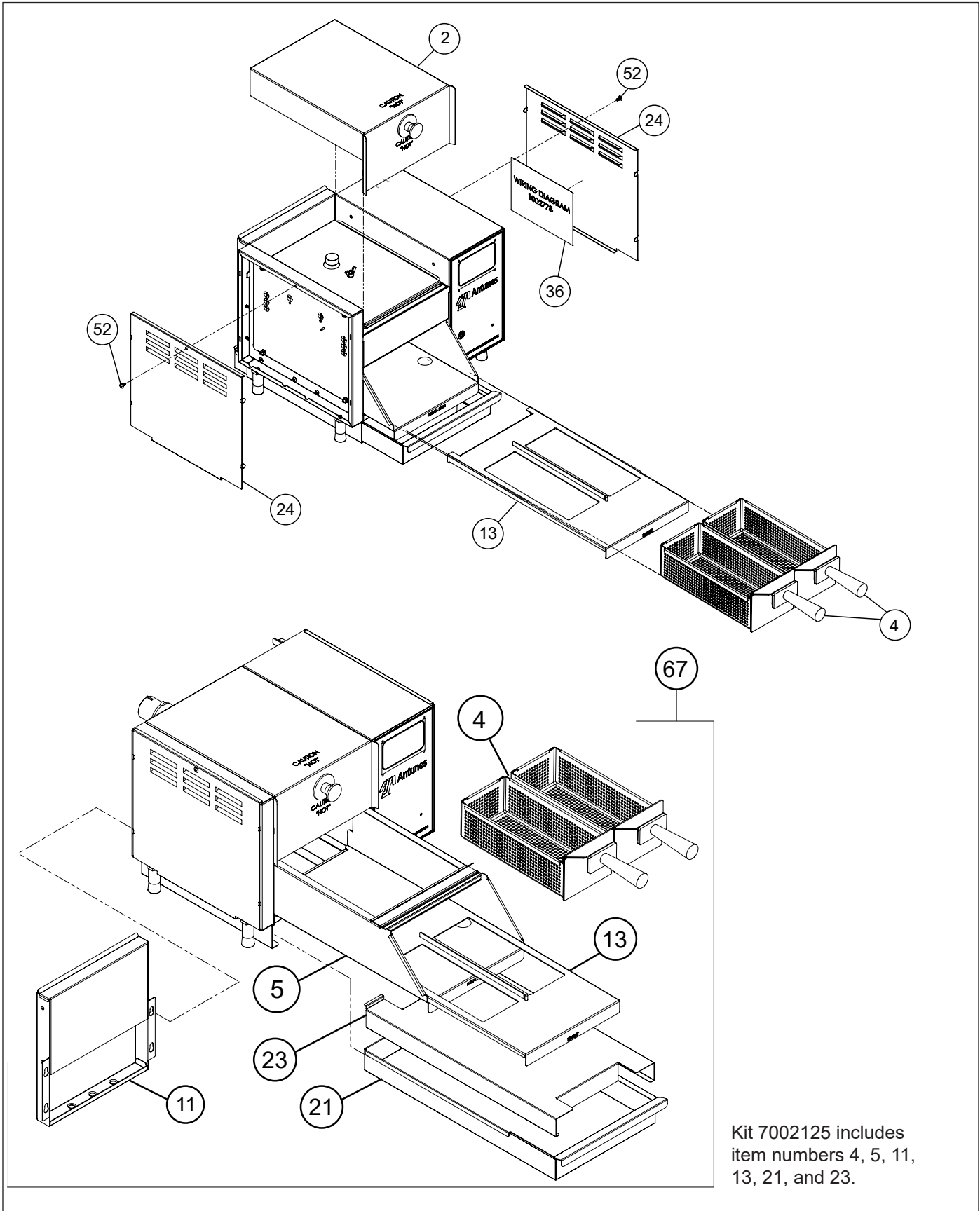

Kit 7002125 includes item numbers 4, 5, 11, 13, 21, and 23.

Exploded Views

Exploded Diagram 6

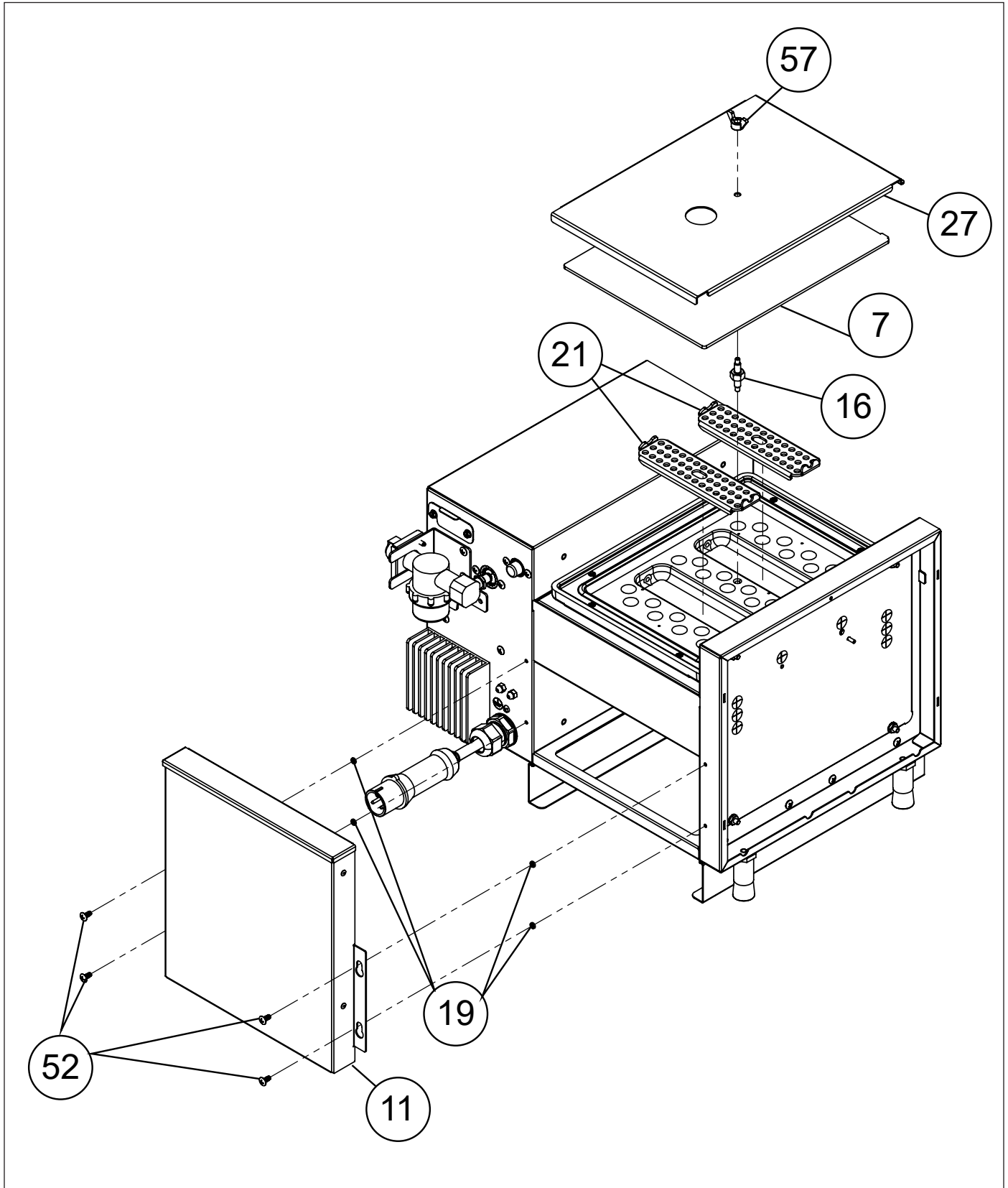

Limited Warranty

Equipment manufactured by Antunes has been constructed of the finest materials available and manufactured to high quality standards. These units are warranted to be free from electrical and mechanical defects for a period of one (1) year from date of purchase under normal use and service, and when installed in accordance with manufacturer's recommendations. To insure continued operation of the units, follow the maintenance procedures outlined in the Owner's Manual. During the first 12 months, electromechanical parts, non-overtime labor, and travel expenses up to 2 hours (100 miles/160 km), round trip from the nearest Authorized Service Center are covered.

1. This warranty does not cover cost of installation, defects caused by improper storage or handling prior to placing of the Equipment. This warranty does not cover overtime charges or work done by unauthorized service agencies or personnel. This warranty does not cover normal maintenance, calibration, or regular adjustments as specified in operating and maintenance instructions of this manual, and/or labor involved in moving adjacent objects to gain access to the equipment. This warranty does not cover consumable/wear items. This warranty does not cover damage to the Load Cell or Load Cell Assembly due to abuse, misuse, dropping of unit/shock loads or exceeding maximum weight capacity (4 lbs). This warranty does not cover water contamination problems such as foreign material in water lines or inside solenoid valves. It does not cover water pressure problems or failures resulting from improper/incorrect voltage supply. This warranty does not cover Travel Time & Mileage in excess of 2 hours (100 miles/160 km) round trip from the nearest authorized service agency.
2. Antunes reserves the right to make changes in design or add any improvements on any product. The right is always reserved to modify equipment because of factors beyond our control and government regulations. Changes to update equipment do not constitute a warranty charge.
3. If shipment is damaged in transit, the purchaser should make a claim directly upon the carrier. Careful inspection should be made of the shipment as soon as it arrives and visible damage should be noted upon the carrier's receipt. Damage should be reported to the carrier. This damage is not covered under this warranty.
4. Warranty charges do not include freight or foreign, excise, municipal or other sales or use taxes. All such freight and taxes are the responsibility of the purchaser.

This warranty is exclusive and is in lieu of all other warranties, expressed or implied, including any implied warranty or merchantability or fitness for a particular purpose, each of which is hereby expressly disclaimed. The remedies described above are exclusive and in no event shall Antunes be liable for special consequential or incidental damages for the breach or delay in performance of this warranty.

The warranty does not extend to:

- Damages caused in shipment or damage as result of improper use.
- Installation of electrical service.
- Installation, calibration, or adjustment.
- Normal maintenance outlined in this manual.
- Malfunction resulting from improper service or maintenance.
- Damage caused by improper installation, abuse, or careless handling.
- Damage from moisture getting into electrical components.
- Damage from tampering with, removal of, or changing any preset control or safety device.
- Damage caused by parts or components not provided by Antunes



Corporate Headquarters
Carol Stream, IL, USA
Phone: +1.630.784.1000
Toll Free: +1.800.253.2991
Fax: + 1.(630).784-1650

China Facility
Suzhou, China
Phone: +84.512.6841.3637
Fax: +86.512.6841.3907

India Facility
Chennai, India
Phone: +91.44.25532212
Fax: +91.44.25532415