

Miracle Steamer

Model MS-250/255 Owner's Manual

Manufacturing Numbers:

9100430, 9100431, 9100435, 9100436,
9100437, 9100438, 9100460, 9100462,
9100466, 9100467, 9100468, 9100933,
9100936



Contents

- Overview.....2**
- Before Use2
- In Case of Damage2
- Website2
- Service/Technical Assistance.....2**
- Safety Information3**
- Installation3
- Operation3
- Maintenance.....3
- Service3
- Specifications4**
- Dimensions4
- Electrical Ratings4
- Installation.....5**
- Unpacking5
- Equipment Setup.....5
- Electrical.....6
- caution.....6
- Plumbing6
- caution.....6
- Operation.....7**
- Programming.....7
- Hi-Limit Reset Button8
- Status Indicator LEDs8
- Fault Codes.....8
- Maintenance.....9**
- Daily9
- Monthly.....10
- Troubleshooting12**
- Replacement Parts14**
- Parts List14
- Exploded Views15**
- Exploded Diagram 1.....15
- Exploded Diagram 2.....16
- Exploded Diagram 3.....17
- Wiring Diagram18**
- Notes.....19**

Overview

This unit is intended to be used for commercial applications, for example: in kitchens of restaurants, canteens, hospitals and in commercial enterprises such as bakeries, butcheries, etc., But not for continuous mass production of food.

Before Use

This manual contains safety, installation, and operating procedures for the unit. Read and understand it completely before installing or operating the unit. Keep this document for reference. If the unit changes ownership, this manual must accompany it.

In Case of Damage

If the unit arrives damaged, file a claim with the carrier immediately. Save all packing materials when filing a claim. Freight damage claims are the responsibility of the purchaser and are not covered under warranty.

Website

www.antunes.com

Service/Technical Assistance

If you experience any problems with the installation or operation of your unit, contact Antunes Technical Service at +1-877-392-7854 (toll free).

Fill in the information in the next column and have it handy when calling for assistance. The serial number is on the specification plate located on the system.

Purchased From

Date of Purchase

Model Number

Serial Number

Mfg. Number

Use only genuine Antunes replacement parts in this unit. Use of replacement parts other than those supplied by the manufacturer will void the warranty.

IMPORTANT

Antunes. reserves the right to change specifications and product design without notice. Such revisions do not entitle the buyer to corresponding changes, improvements, additions or replacements for previously purchased equipment.

IMPORTANT

Keep these instructions for future reference. If the unit changes ownership, be sure this manual accompanies the equipment.

Safety Information

Installation

- Read and understand all instructions before installing or using the unit.
- The unit **MUST** be installed by personnel qualified to work with electricity and plumbing.
- Install this unit to comply with the basic plumbing code of the Building Officials and Code Administrators, Inc. (BOCA) and the Food Service Sanitation Manual of the Food and Drug Administration (FDA).
- Install and locate the equipment only for its intended use as described in this manual.

WARNING

ELECTRICAL SHOCK HAZARD.
Failure to follow the instructions in this manual could result in serious injury or death.

Do NOT modify the power supply cord plug. If it does not fit the outlet, have a proper outlet installed by a qualified electrician.

Electrical ground is required on this appliance.

Check with a qualified electrician if you are unsure if the appliance is properly grounded.

Do NOT use an extension cord with this product.

The unit should be grounded according to local electrical codes to prevent the possibility of electrical shock. It requires a grounded receptacle with separate electrical lines, protected by fuses or circuit breaker of the proper rating.

NEVER unplug the power cord while the unit is running. Use the proper shutdown procedure before unplugging the power cord.

Operation

- The unit is furnished with a properly grounded cord connector. Do not attempt to defeat the grounded connector.
- Do not operate the unit if it has been damaged or dropped, if it has a damaged cord or plug, or if it is not working properly.
- Do not block or cover any openings on the equipment.
- Do not immerse the cord, unit, or plug in water.
- Keep the cord away from heated surfaces.
- Do not allow the cord to hang over the edge of a table or counter.
- Keep the area around the unit free and clear of all combustible materials. Failure to do so may result in fire or property damage.

WARNING: To avoid scalding, do not use loaded containers with liquids or cooking goods which becomes fluid by heating in higher levels than those which can be easily observed.

WARNING: Opening steamer drawers during operation releases steam. Compartment and contents may be hot.

Maintenance

- Do not use abrasive materials; they can damage the unit's stainless steel finish.
- Do not use corrosive chemicals in this equipment.
- Chlorides or phosphates in cleaning agents (e.g., bleach, sanitizers, degreasers, and detergents) can permanently damage stainless steel equipment. The damage is usually in the form of discoloration, dulling of the metal surface finish, pits, voids, holes, or cracks. This damage is permanent and is not covered by warranty.
- Always use a soft, damp cloth for cleaning. Rinse with clear water and wipe dry. When required, always rub in the direction of metal polish lines.
- Routine cleaning should be performed daily with soap and water.
- Do not clean unit or components in a dishwasher unless specifically specified in the cleaning instructions.

- Do not clean the unit with a water jet or steam cleaner.

Service

- Inspection, testing, and repair of electrical equipment must be performed only by qualified service personnel.
- To avoid possible personal injury and/or damage to the unit, all inspections, tests, and repair of electrical equipment should be performed by qualified personnel **ONLY**. Contact Antunes Technical Service for adjustment or repair.
- Turn the power off, unplug the power cord, and allow unit to cool to room temperature before performing any service or maintenance.
- If the supply cord is damaged, it must be replaced by the manufacturer, its service agent, or a similarly qualified person in order to avoid an electrical hazard.
- Cleaning and user maintenance shall not be made by children without supervision.

Specifications

Dimensions

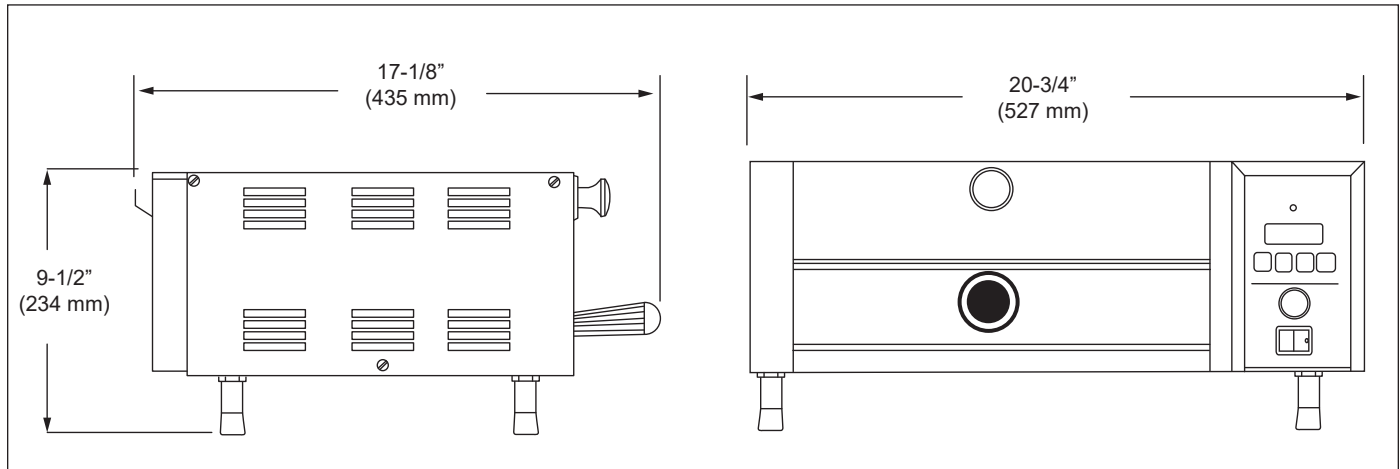

Electrical Ratings

Model & Mfg. No.	Volts	Watts	Amps	Hertz	Plug Description
MS-250 9100430	208	3300	15.9	50/60	6-20P, 20 Amp., 250 VAC, Non Locking
MS-250 9100431 Saudi Arabia	230	3300	14.4	50/60	IEC-309 16 Amp., 250 VAC Pin & Sleeve (Assembly Only)
MS-250 9100435	208	3300	15.9	50/60	6-20P, 20 Amp., 250 VAC, Non Locking
MS-250 9100436	230	3300	14.4	50/60	6-20P, 20 Amp., 250 VAC, Non Locking
MS-250 9100437	230	3300	14.4	50/60	6-20P, 20 Amp., 250 VAC, Non Locking
MS-250 9100438	230	3300	14.4	50/60	CEE 7/7, 16 Amp., 250 Volt
MS-255 9100460	230	3300	14.4	50/60	6-20P, 20 Amp., 250 VAC, Non Locking
MS-255 9100462	120	1800	15.0	50/60	NEMA 5-15P, 15 Amp., 120 Volt
MS-255 9100466	230	3300	14.4	50/60	6-20P, 20 Amp., 250 VAC, Non Locking
MS-255 9100467 Saudi Arabia	230	3300	14.4	50/60	IEC-309 16 Amp., 250 VAC Pin & Sleeve (Assembly Only)
MS-255 9100468	230	3300	14.4	50/60	CEE 7/7, 16 Amp., 250 Volt
MS-255 9100933	208	3300	15.9	50/60	6-20P, 20 Amp., 250 VAC, Non Locking

Installation

Unpacking

1. Remove the unit and all packing materials from the shipping carton.
2. The unit should come with the items listed below:
 - Owner's Manual
 - Inlet Hose Assembly
 - Spatula Assembly (MS-250 only)
 - Drawer Assembly (MS-255 only)

NOTE: If any parts are missing or damaged, contact Antunes Customer Service IMMEDIATELY at +1-877-392-7856 (toll free)

3. Remove all packing materials and protective coverings from the unit.
4. **MS-250:** Remove and wash the Wire Trivet, Spatula, Spatula Liner, and Drip Pan (Figure 1) in soap and water. Rinse with clean hot water and allow to air dry.
5. **MS-255:** Remove and wash the Drawer, Drawer Liner with Rollers, and Drip Pan (Figure 2) in soap and water. Rinse with clean hot water and allow to air dry.

NOTE: MFG. No. 9100933 does not use the Drip Pan or Steam Vent.

6. Wipe all surfaces of the unit with a hot, damp cloth.

NOTE: Do NOT use a dripping wet cloth. Wring out before use.

7. **MS-250 Models:** Assemble the Guard and Mounting Bolt to the Spatula (Figure 3). Then install the Wire Trivet into the side slots on the Spatula.
8. Re-install all removed parts.

Equipment Setup

When placing the unit into service, pay attention to the following guidelines:

- Make sure power is off and the unit is at room temperature.
- Do NOT block or cover any openings on the unit.
- Do NOT immerse cord or plug in water.
- Keep cord away from heated surfaces.
- Do NOT allow cord to hang over edge of table or counter.

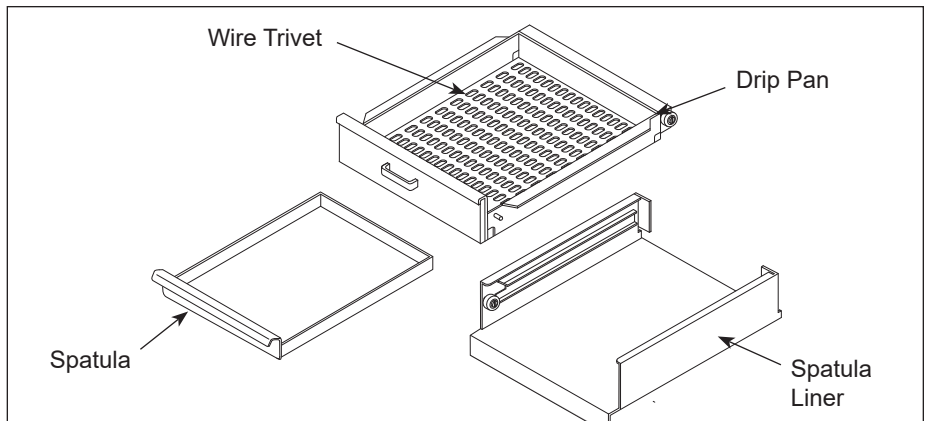

Figure 1. Washing Parts—MS-250 Only

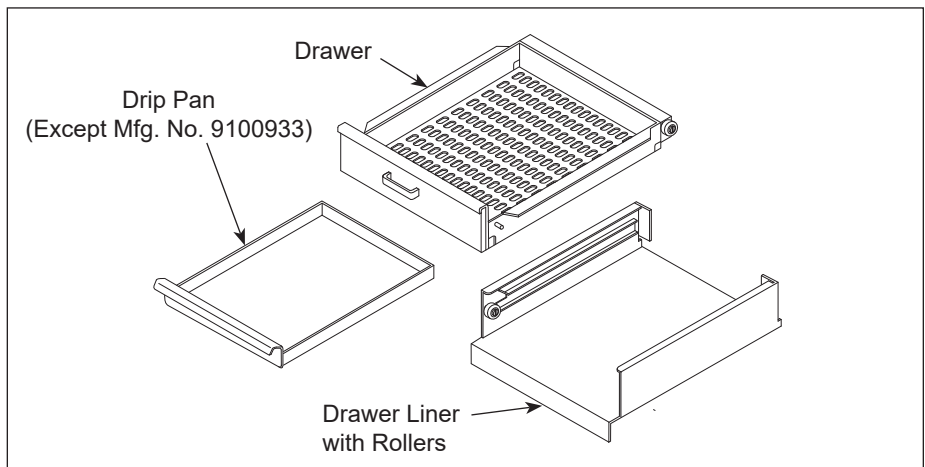

Figure 2. Washing Parts—MS-255 Only

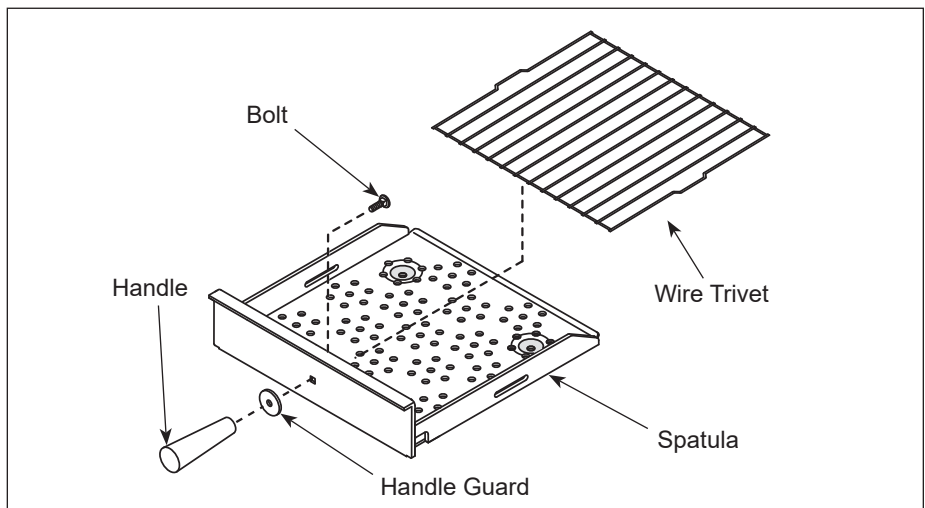

Figure 3. Assembling Handle—MS-250 Only

Electrical

1. Place the unit on a sturdy, level table or other work surface.
2. Ensure that the line voltage corresponds to the stated voltage on the units specification label and power cord warning tag. **If you are unsure of your Line Voltage, contact an electrician.**
3. Connect the unit to the power supply.

<p>WARNING THIS APPLIANCE MUST BE EARTHED (GROUNDED)</p>	<p>WARNING THIS APPLIANCE MUST BE EARTHED (GROUNDED)</p>
<p>120 VAC ONLY</p>	<p>THIS UNIT IS DESIGNED TO OPERATE ON 120 VOLTS ONLY. APPLICATION WITH ANY OTHER VOLTAGE SUPPLY COMPLETELY VOIDS ALL WARRANTY. PLEASE CHECK YOUR LINE VOLTAGE BEFORE INSERTING THIS PLUG INTO THE RECEPTACLE.</p>
<p>WARNING THIS APPLIANCE MUST BE EARTHED (GROUNDED)</p>	<p>WARNING THIS APPLIANCE MUST BE EARTHED (GROUNDED)</p>
<p>208 VAC ONLY</p>	<p>THIS UNIT IS DESIGNED TO OPERATE ON 208 VOLTS ONLY. APPLICATION WITH ANY OTHER VOLTAGE SUPPLY COMPLETELY VOIDS ALL WARRANTY. PLEASE CHECK YOUR LINE VOLTAGE BEFORE INSERTING THIS PLUG INTO THE RECEPTACLE.</p>
<p>WARNING THIS APPLIANCE MUST BE EARTHED (GROUNDED)</p>	<p>WARNING THIS APPLIANCE MUST BE EARTHED (GROUNDED)</p>
<p>220-240 VAC ONLY</p>	<p>THIS UNIT IS DESIGNED TO OPERATE ON 220-240 VOLTS ONLY. APPLICATION WITH ANY OTHER VOLTAGE SUPPLY COMPLETELY VOIDS ALL WARRANTY. PLEASE CHECK YOUR LINE VOLTAGE BEFORE INSERTING THIS PLUG INTO THE RECEPTACLE.</p>

Plumbing

NOTE: Miracle Steamer models are designed to use cold tap water. Distilled water may be used to reduce calcium/mineral deposit buildup and reduce maintenance costs.

These units require a direct cold water hookup. A Water Inlet Hose and Strainer Assembly (Figure 4) is supplied.

NOTE: Incoming water is controlled by a normally closed (NC) solenoid valve located inside the Steamer's electrical housing.

1. Turn off the water valve (not supplied) that supplies water to the unit (Figure 4).
2. Connect the 1/4" (6.5 mm) I.D. Flexible Tubing to the outlet side of the Water Pressure Regulator and secure using the Worm Clamp (Figure 4).

NOTE: A Water Pressure Regulator must first be installed (Figure 4). Failure to do so will result in poor steaming and possible flooding. For a single steamer, use Water Pressure Regulator P/N 7000314. For two adjacent steamers, use Water Pressure Regulator P/N 7000235. For Mfg. No. 9100933 use only P/N 0012001.

3. Turn the water valve on.
4. Hold the Quick Disconnect Insert over a bucket, then press and hold the white plastic tip until there's a good, steady water flow. This will purge all air out of the line.
5. Release the plastic tip and check the pressure on the Water Pressure Regulator. It should read 20 psi.
 - a. If it reads less, increase the water pressure by pulling the black knob up and turning it clockwise.
 - b. If it reads more, decrease the water pressure by pulling the black knob up and turning it counter clockwise.

NOTE: When adjusting the knob, relieve the existing pressure by pressing the plastic tip on the Quick Disconnect Insert for 3 seconds. The Water Pressure Regulator will then show the new pressure.

3. Once the regulator reads 20 psi, push the black knob down to lock it in place.
4. Push the Quick Disconnect Insert into the fitting at the rear of the unit until it clicks (Figure 4).

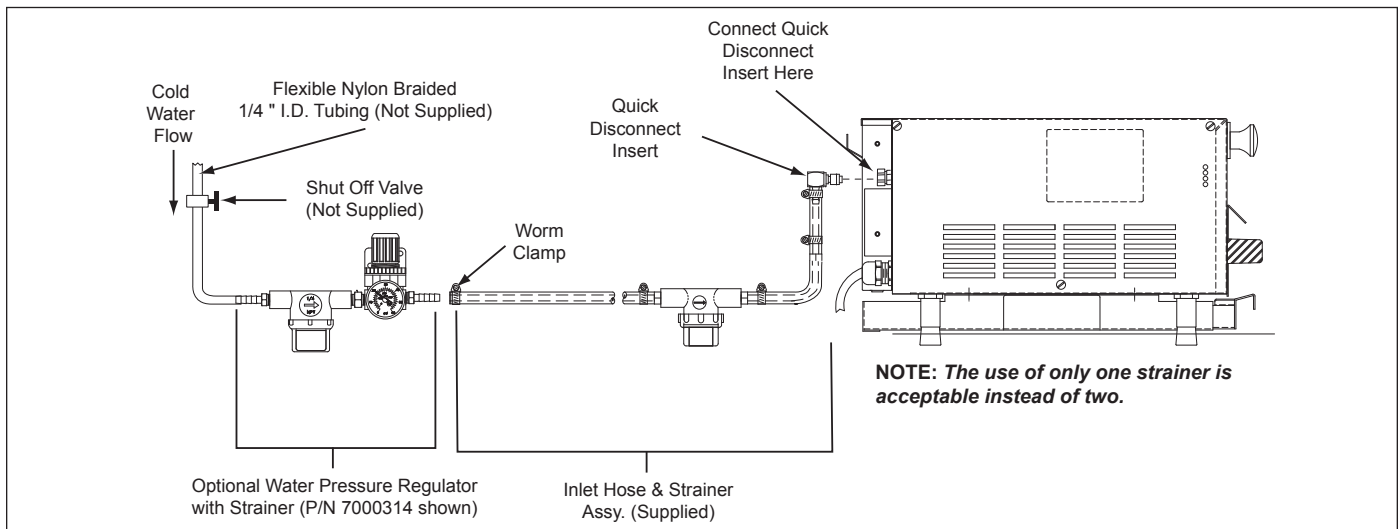

Figure 4. Connecting Water Supply

CAUTION

Water pressure must not exceed 30 psi (2.1 kg/cm² or 207 kPa). Higher pressure may cause poor performance or flooding. To reduce water pressure, install a Water Pressure Regulator, and set to 20–25 psi (1.4–1.7 kg/cm² or 138–172 kPa).

CAUTION

This equipment is to be installed to comply with the basic plumbing code of the Building Officials and Code Administrators, Inc. (BOCA) and the Food Service Sanitation Manual of the Food and Drug Administration (FDA).

Operation

1. Turn the power on and allow the unit to preheat for approximately 20–30 minutes.

NOTE: Do NOT push any button during warmup time. The flashing green Ready Light indicates that the unit is not warmed up. The green Ready Light will become steady when the unit is warmed up.

2. Pull out the Spatula or Drawer Assembly and set the product to be steamed onto the Spatula.
3. Push the Spatula or Drawer Assembly fully into the steamer.
4. **Single Shot:** Press and release the Operate button, then wait 20 seconds for the steam to penetrate the product.

Timed Cycle: Press the Start/Stop button to begin the steaming cycle. The display will count down to zero and an audio signal will sound at the end of the steaming cycle.

5. Remove steamed product.

Programming

CYC (Total Cycle Time) refers to the total programmed steam time set for the product.

SHO (Shot Interval Time) refers to the time set between shots of steam during a complete cycle.

H2O (Steam Shot Time) refers to the water volume consumed during each water pump activation.

The amount of steam produced by your Miracle Steamer depends on the amount of water sprayed onto the steam generator.

Flooding of the generator may occur if the H2O setting is too high. To prevent flooding, the Shot Interval Time (SHO) can be increased to allow more time for generator heat recovery. Adjustments should be made to both values to determine the best settings for your cooking needs.

To program the control, refer to Figure 6 and follow the procedure below:

1. Turn the unit on. The unit displays the factory programmed Total Cycle Time in minutes and seconds (Figure 6, Item A).
2. Press and release  to change the control from OPERATION to PROGRAM mode.

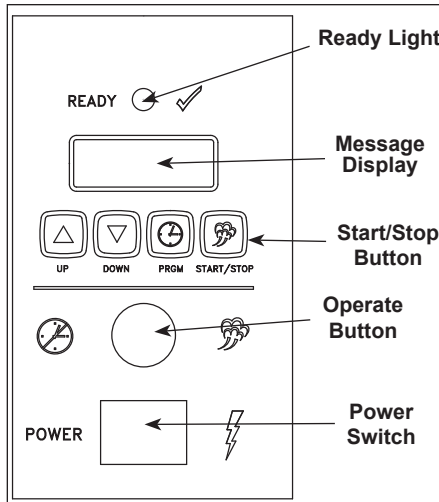

















Figure 5. Operating Controls

3. To change the Total Cycle Time in minutes, press  or  to change the time (Figure 6, Item B).
4. Press and release  again, and press  or  to change the Total Cycle Time in seconds (Figure 6, Item C).
5. To change the SHO factory settings, make sure the control is in PROGRAM mode, then press and hold both  and  simultaneously for 1-2 seconds and release. SHO will be displayed (Figure 6, Item D).
6. Press and release  and then press  or  to change the SHO in seconds (Figure 6, Item E).
7. Press and release  again and press  or  to change the SHO in minutes (Figure 6, Item F).
8. Press and release  again and "H2O" will be displayed (Figure 6, Item G).
9. To change the H2O (Steam Shot time), press and release the Program button again to display the setting (Figure 6, Item H). Use  or  to increase or decrease the time.
10. Press the Start/Stop or Operate buttons to store the changes, exit the PROGRAM Mode, and initiate the cooking cycle.

WARNING

To avoid injury, be careful when pulling the Spatula or Drawer out from unit. Be sure to allow steam to escape before putting hands or face over the steamer.

NOTE: 208V and 220/240V Miracle Steamers are factory programmed for the following recommended settings:

- Total Cycle Time (CYC) = 15 min., 00 secs. (Range: 3 seconds to 99 minutes 59 seconds)
- Shot Interval Time (SHO) = 00 min., 20 secs. (Range: 3 seconds to 5 minutes 59 seconds)
- Steam Shot Time (H2O) = 0_70 (Range: 0_10 second to 2_50)

This converts approximately 3/4 oz. (25 milliliters) of water to steam every 20 seconds for a 15 minute cooking cycle.

NOTE: 120V Miracle Steamer is factory programmed for the following recommended settings:

- Total Cycle Time (CYC) = 2 min., 00 secs. (Range: 3 seconds to 99 minutes 59 seconds)
- Shot Interval Time (SHO) = 00 min., 20 secs. (Range: 3 seconds to 5 minutes 59 seconds)
- Steam Shot Time (H2O) = 0_40 (Range: 0_10 seconds to 2_50)

NOTE: The Start/Stop or Operate buttons may be pressed at any time during programming to store the changes and exit the PROGRAM Mode.

NOTE: If a change is not made within 5 seconds at any time during the programming process, all changes made up to that point are stored in memory and the control reverts to the OPERATION Mode.

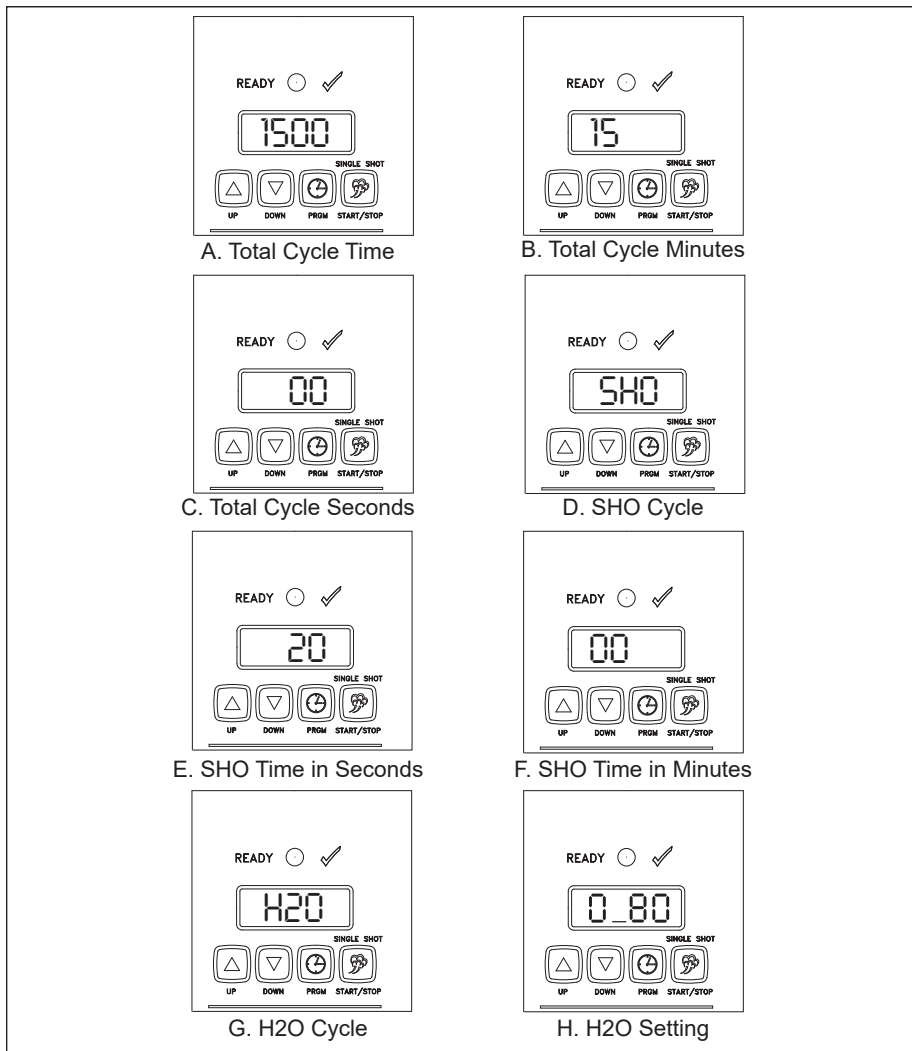

Figure 6. Control Programming Sequence

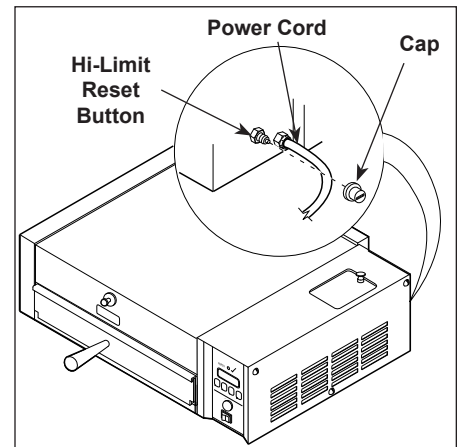

Figure 7. Hi-Limit Reset Button

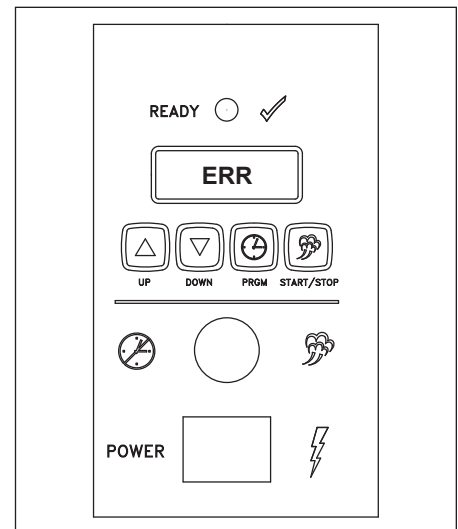

Figure 8. "ERR" Fault Code

Hi-Limit Reset Button

A hi-limit thermostat turns off electrical power to the steam generator if it overheats. To reset this thermostat, allow approximately 45 minutes for the unit to cool down, remove the black cap, and then press the Hi-Limit Reset button located on the rear of the unit (Figure 7). If the unit requires continuous resetting, contact Antunes Technical Service.

Status Indicator LEDs

The Miracle Steamer's Control Board has four status indicator LEDs described below:

Green (Program): When lit, indicates the unit is in Program mode.

Yellow (Audio): When lit, indicates 10-15 VDC is being supplied to the audio signal. The audio signal sounds and the LED lights for approximately 3 seconds.

Red (Heat): When lit, indicates the Control Board is calling for heat by supplying 10-15 VDC to the Solid State Relay. When off, indicates that the unit is satisfied.

Green (H2O): When lit, indicates that 24 VAC is being supplied to operate the solenoid valve. This LED is only lit for approximately 1 second.

Fault Codes

When the programming parameters for Minutes/Seconds/SHO/H2O have been inadvertently changed below or above their limits, the unit displays the "ERR" fault code (Figure 8). If this code appears, clear these settings using the procedure below:

1. Turn the unit off.
2. Press and hold the Program and Start/Stop buttons simultaneously

3. Turn the unit on while continuing to hold the Program and Start/Stop buttons. Release the buttons when the unit stops beeping,
4. The display will now register the cycle time.

NOTE: Repeat these steps if the unit still displays the "ERR" fault code.

NOTE: It is recommended that the SHO and H2O settings be adjusted to the recommended settings shown in the Programming section of this manual.

Maintenance

Daily

NOTE: Frequency of cleaning is determined by water conditions, usage, and water filtration systems.

⚠ CAUTION

Chlorides or phosphates in cleaning agents (such as bleach, sanitizers, degreasers, or detergents) could cause permanent damage to stainless steel equipment. The damage is usually in the form of discoloration, dulling of metal surface finish, pits, voids, holes, or cracks. This damage is permanent and not covered by warranty. The following tips are recommended for maintenance of your stainless steel equipment:

- Always use a soft, damp cloth for cleaning, rinse with clear water, and wipe dry. When required, always rub in direction of metal polish lines.
- Routine cleaning should be done daily using soap, ammonia detergent, and water.
- Stains and spots should be removed using a vinegar solution.
- Finger marks and smears should be rubbed off using soap and water.
- Hard water spots should be removed using a vinegar solution.

4. **MS-250:** Remove the Spatula, Spatula Liner, Drip Pan, Top Cover, and Steam Vent (Figure 9).

MS-255: Remove the Drawer, Drawer Liner with Rollers, Drip Pan, Top Cover, and Steam Vent (Figure 10).

NOTE: MFG. No. 9100933 does not use the Drip Pan or Steam Vent.

5. Wash items in hot, soapy water and then rinse and wipe dry.
6. Wipe down the food compartment and the entire exterior of the unit with a clean, hot, damp cloth (not dripping wet) and wipe dry.

7. Reinstall the Steam Vent first, followed by the remaining items.

NOTE: Failure to properly clean and dry the items prior to reassembly may result in the accumulation of water/moisture overnight. This could permanently damage of the equipment's finish and its accessories. This damage is NOT covered by warranty.

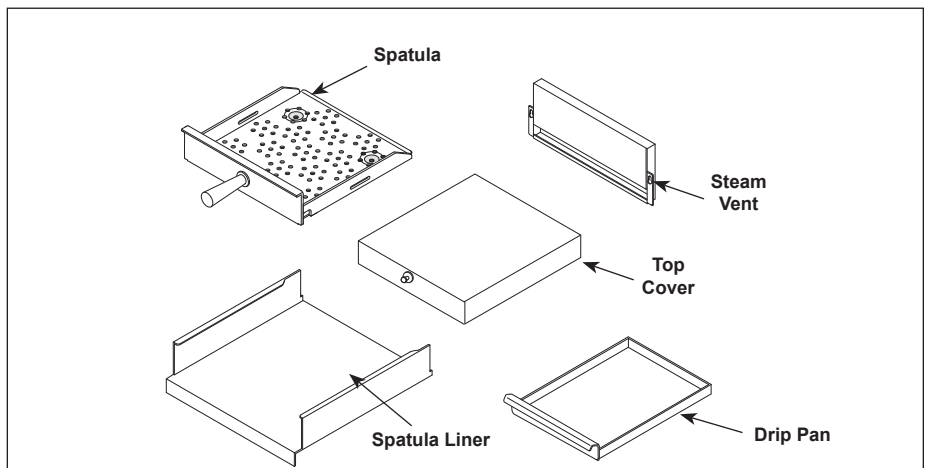

Figure 9. Daily Cleaning-MS-250

⚠ CAUTION

If a chemical cleaner is used, be sure it is safe to use on cast aluminum. Observe all precautions and warnings on product label.

1. Turn the power off, unplug the power cord, and allow the unit to cool down before proceeding.
2. Check the Water Pressure Regulator gauge and verify that it reads 20–25 psi (1.4–1.7 kg/cm² or 138–172 kPa). If not, adjust the pressure as described in the Installation section of this manual.
3. Check the rear water Quick Disconnect Fitting and Hose Clamp for leakage. Tighten clamps or replace parts if needed.

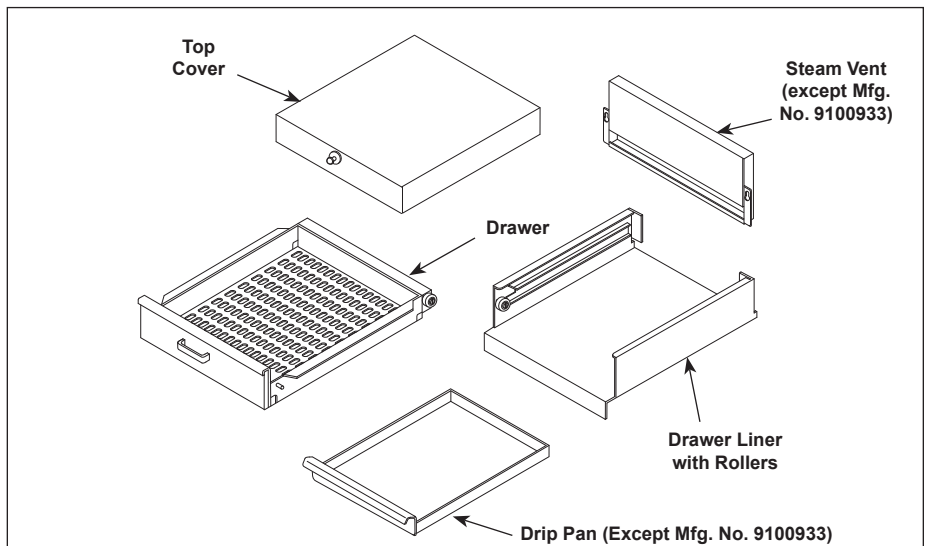

Figure 10. Daily Cleaning-MS-255

Monthly

The Miracle Steamer utilizes an open steam Generator. Water sprayed onto the Generator surface flashes into steam immediately, but the minerals in the water do not steam, they stay on the Generator surface. A small amount of calcium/mineral deposits are needed for proper operation, but a buildup of excessive calcium/mineral deposits causes poor steaming efficiency and excessive moisture (wet steam), which will eventually severely hinder the steaming action.

CAUTION

If a chemical cleaner is used, be sure it is safe to use on cast aluminum. Observe all precautions and warnings on product label.

Cleaning Steam Generator

1. Turn the power off, unplug the power cord, and allow the unit to cool down.
2. Perform the Daily cleaning, but do NOT reassemble the unit.
3. Remove the Wing Nut, Generator Cover, and Diffuser (Figure 11). Wash these items in hot, soapy water, rinse and WIPE DRY.
4. With the unit cool, use a wire brush and/or scraper to loosen and remove the excessive calcium/mineral deposits from the Generator surface.
5. Take a wire brush and clean out any buildup from the 28 Steam Ports (26 vertical and 2 horizontal) of the Generator (Figure 11). Remove the loose buildup, wipe the Generator with a clean, damp cloth, and reassemble the unit.

NOTE: If deposits are still excessive and/or difficult to remove, refer to Steps 6 and 11.

6. Pour delimer solution (not supplied) onto the Generator surface. Follow the delimer manufacturer's instructions for proper mixture and use.
7. Using a sponge or a dry towel, remove the delimer solution from the Generator surface, then rinse with clean water.

NOTE: To ensure proper steaming characteristics, some calcium/mineral deposits must be present on the Generator surface. If, during cleaning, the surface does become free of calcium/mineral deposits, add plain tap water to the surface and allow it to boil off. If necessary, repeat this process to formulate a thin coating of calcium/mineral deposits.

NOTE: In soft water areas, it may be necessary to add a small amount of baking soda to the Generator to "season" it. This will ensure proper steaming characteristics by producing a thin coating of calcium/mineral deposits on the Generator surface.

Seasoning mixture consists of 3/4 ounces (25ml/ 25cc) baking soda and 1 quart (950ml/950cc) of water. Stir mixture and pour 1/4" deep onto the hot Generator surface. After mixture is converted to steam, the remaining loose power can be removed.

8. Plug the power cord into the appropriate outlet.
9. Turn the power on and allow the unit to warm up for approximately 30 minutes.
10. Push and release the Operate button or the Start/Stop button several times to operate the steamer. This purges any remaining delimer residue from the Generator surface.
11. Turn the power off, reinstall all parts and accessories, and return the unit to service.

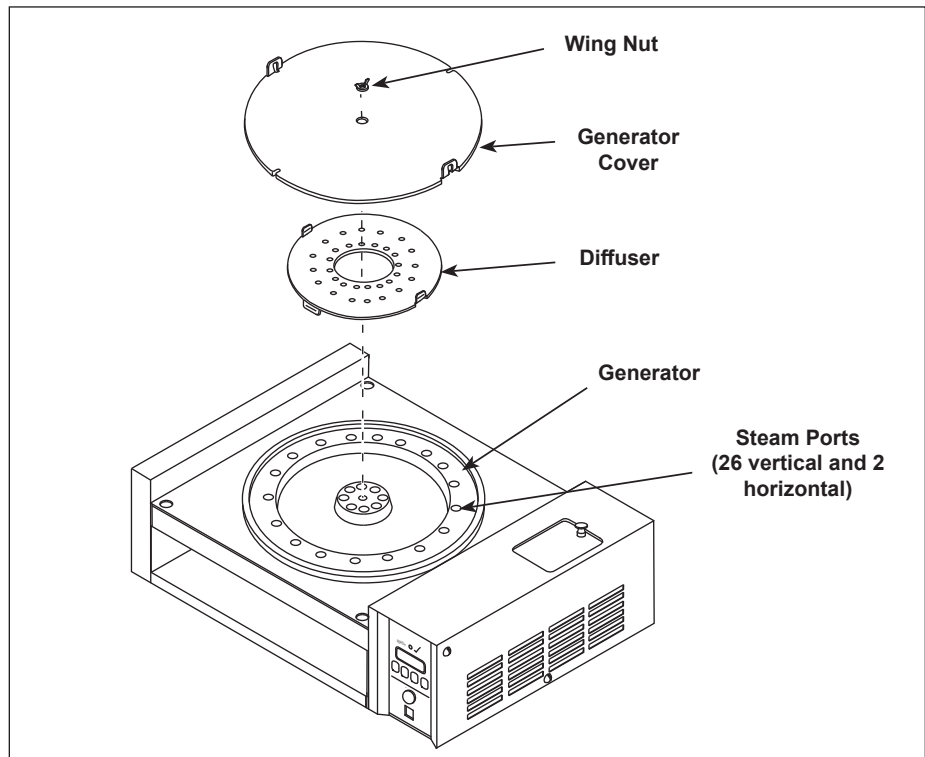

Figure 11. Monthly Cleaning

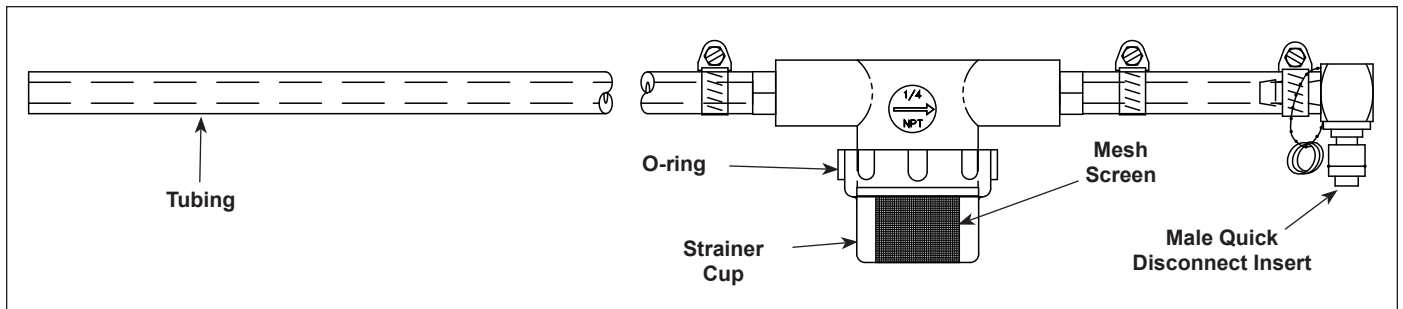

Figure 12. Inlet Hose Assembly

Checking and Cleaning the Water Strainer

The Water Strainer protects your equipment from any foreign debris in the water line that could get into the food or damage the unit's solenoid and cause the unit to leak or flood. It also protects the equipment's proper and consistent operation from interference.

To ensure proper and consistent steaming results, check the Water Pressure Regulator and Strainer Cup regularly. If the pressure has dropped, check the Strainer Cup and clean out the accumulated debris as follows.

1. Shut off the water supply valve to the unit, unscrew the clear, plastic Strainer Cup and carefully remove the Mesh Screen.
2. At the sink, gently flush all of the accumulated debris from the Strainer Cup and Mesh Screen. Be especially careful not to damage the Mesh Screen.
3. Carefully place the Mesh Screen into its seat at the bottom of the Strainer Cup and confirm that the orange O-ring is properly seated in its place before screwing the Strainer Cup and top back together.
4. Purge the air out of the strainer and tubing by disconnecting the Male Quick Disconnect Insert from the equipment and, over a bucket, push the white plastic tip in until there is good water flow.
5. Replace damaged or worn parts as needed.
6. Verify that the Water Pressure Regulator is set to 20–25 psi (1.4–1.7 kg/cm² or 138–172 kPa).

Troubleshooting



WARNING

To avoid possible personal injury and/or damage to the unit, inspection, test and repair of electrical equipment should be performed by qualified service personnel. The unit should be unplugged when servicing.

Problem	Possible Cause	Corrective Action
Control Display is blank (power is on but indicator light is off).	The power cord is not correctly plugged in.	Plug the power cord into the appropriate outlet.
	The power cord and/or electrical plug is damaged.	Inspect electrical wire, plug, and receptacle.
	The main electrical panel circuit breaker is off or has been tripped.	Reset circuit breaker. Contact your maintenance person or Antunes Technical Service if it trips again.
	Switch is inoperable.	Contact your maintenance person or Antunes Technical Service.
Control Display is blank (power is on and indicator light is on).	Control Board is inoperable	Contact your maintenance person or Antunes Technical Service.
	Transformer is inoperable.	
	Loose, burnt, or broken wires in circuit.	
Unit does not heat up (Control Display is on).	Hi-Limit Thermostat is tripped or inoperable.	Reset the Hi-Limit Thermostat according to the Operations section of this manual. If the Hi-Limit Thermostat requires continuous resetting, contact your maintenance person or Antunes Technical Service.
	Solid State Relay is inoperable.	
	Thermocouple is inoperable.	
	Control Board is inoperable.	
	Steam Generator is inoperable.	
	Loose, burnt, or broken wires in circuit.	
The unit's main electrical panel circuit breaker trips.	Damaged receptacle, plug, or cord; a loose connection; or an internal component failure.	Turn the unit off, allow it to cool to room temperature, and then restart. Contact your maintenance person or Antunes Technical Service if the condition repeats.
Water leaking inside electrical housing.	Loose or damaged water line tubes and/or fittings inside electrical housing.	Tighten or replace tubes and/or fittings.
"ERR" appears in the Control Display.	Programming and/or SHO and H2O values were adjusted/changed improperly.	Reset the Control Board as described in the Programming section of this manual. See Fault Codes.

Troubleshooting

Problem	Possible Cause	Corrective Action
Unit heats but there is little or no steam produced And/or The product requires more steaming than usual.	Water Line Valve is closed.	Check that the Water Line Valve is open.
	Filter Strainer is restricted.	Check and clean the Filter Strainer as described in the Maintenance section of this manual.
	Quick Disconnect is not fully engaged at rear of the unit or is damaged.	Remove and reengage the Quick Disconnect firmly until a click is heard. Replace if damaged.
	Low or no water pressure in the water line.	Remove the Quick Disconnect Insert from the rear of the unit. While holding over an empty cup, press the white tip. Strong, steady water flow should be noted. If so, reengage firmly into unit. If not present, or pressure is low, contact your maintenance person or plumber.
	Improper water pressure to unit.	Verify that a Water Pressure Regulator is installed and set to 20–25 psi.
	Unit is not being cleaned properly (daily/monthly).	Clean unit daily and monthly as described in the Maintenance section of this manual.
	Programming and/or SHO, H2O values were adjusted/changed improperly.	Reprogram the SHO and H2O values as described in the Programming section of this manual.
	Insufficient or excessive calcium/mineral deposits on the Generator surface.	Verify that thin layer of calcium/mineral deposits is present on the Generator surface. Refer to the Maintenance section of this manual.
	Generator surface is bare.	Generator surface must have a thin calcium/mineral coating for proper steaming. Refer to the Maintenance section of this manual.
	Generator Steam Ports are restricted.	Clean the Steam Ports as described in the Maintenance section of this manual.
	Generator Cover is warped or loose.	Verify that the Generator Cover Wing Nut is tight. If noticeable steam escapes around the Generator Cover, replace the cover.
	Generator Diffuser is missing.	Install Generator Diffuser or replace if missing.
	Generator surface temperature is too low.	Verify Generator surface temperature to be 380–420°F (193–215°C).
Excessive condensation in Food Compartment.	Water pressure is too high.	Verify that the Water Pressure Regulator is set to 20–25 psi. Adjust accordingly.
	Programming and/or SHO and H2O values were adjusted improperly.	Reprogram the SHO and H2O values as described in the Programming section of this manual.
Steam coming out around top covers or sides.	Generator Cover's Wing Nut is loose.	Tighten Wing Nut.
	Generator Cover is warped.	Replace Generator Cover.
Unit floods overnight and/or continues to steam even when in idle mode.	Solenoid Valve is leaking due to debris trapped inside the plunger.	Attempt to flush the debris out of the valve by rapidly operating the unit on a number of single shot cycles and then letting it rest. If the unit still leaks, disassemble the Solenoid Valve and clean out the plunger. Reassemble unit and test. If a leak is still present, replace the Solenoid Valve. Contact your maintenance person or Antunes Technical Service.
	Solenoid Valve is installed incorrectly.	If the Solenoid Valve was replaced, verify that the "IN" and "OUT" labels on the valve correspond to the water flow.
	There is no pre-strainer or filter on the water line just before the unit .	Equipment was supplied with a strainer. If missing, install strainer.

Replacement Parts

Parts List

See Exploded Diagrams below

Note

Use only genuine Antunes replacement parts in this unit.
Use of parts other than those supplied by the manufacturer will void the warranty.

Item No.	Part #	Description	Qty.
1	0011123	Solenoid Valve Assy. (Incl. # 5 & 97)	1
2	7000652	Relay	1
3	0010584	Inlet Hose Assy. w/ strainer	1
5	4040145	Solenoid Valve 24 VAC	1
6	7000237	Top Cover Assy. (Incl. #41 & #42)	1
7	0011314	Steam Vent Assy. (All except Mfg. No. 9100933)	1
8	0021131	Floor/Chassis Weldment	1
10	7000246	Generator, 230V	1
	7000245	Generator, 208V	1
	7000300	Generator, 120V	1
11	0300129	Stud, Cover Hold Down	1
12	040P138*	Locknut, 1/2"	1
13	040K251	Strain Relief (Incl. #12)	1
14	05P2199*	Spacer	2
15	0503431	Diffuser, Steam	1
17	0503433	Cover, Generator	1
18	0503434	Cover, End Housing	1
19	0503435	Retainer, Thermocouple	1
21	0021314	Liner, Cavity (MS-250 only)	1
21a	0504081	Liner Cavity (not Shown) (For Mfg. No. 9100437 only)	1
22	0503441	Access Cover	1
23	0503472	Bracket, Hi-Limit Support	1
24	0700452	Power Cord, NEMA 6-20P (Mfg. No. 9100430, 9100435, 9100436, 9100467, 9100460, 9100466 & 9400933)	1
	0700453	Power Cord, CEE 7/7 (Mfg. No. 9100438, 9400440, & 9100468)	1
	0700463	Power Cord, Nema 5-15P (Mfg. No. 9100462)	1
	0700437	Power Cord IEC-309 (Mfg. No. 9100431 & 9100467)	1
26	100P967	Label, Marking	1
27	1001036	Label, Control Panel	1
28	2000203	Tube, Restrictor, 1/4"	1
29	2000207	Tube, Inlet, 1/4 x 2-1/2" Long	1
30	2040103	Connector, Male, 1/4 x 1/8 NPT	1
32	2040145	Elbow, Female, 1/8" x 1/4"	1
33	2040146	Tee, Female, 1/8" x 1/4"	1
34	7000694	Water Fitting Kit (Incl. #28, 29, 30, 32, & 33)	1
35	210K108	Foot, Rubber (4 Pack)	1
36	2100119	Handle, Spatula (MS-250 only)	1
37	4050180	Heat Sink	1
41	2100249	Guard, Knob	1
42	2100273	Knob	1

Item No.	Part #	Description	Qty.
46	7000449	Generator Tube, 4-1/2" Lg.	1
48	300P102*	Nut, Speed, "U", #8-32	2
49	304P105*	Nut, Hex, KEPS, #4-40, Zinc	4
50	306P101*	Nut, Hex, #6-32	2
51	306P105*	Screw, Machine, #6-32 x 1/2"	2
52	306P123*	Screw, Machine, #6-32 x 7/8"	2
53	306P130*	Nut, Hex, KEPS, #6-32	2
54	306P134*	Screw, Machine, #6-32 x 3/8	3
55	308P103*	Screw, Machine, #8-32 x 1/4"	6
57	308P105*	Screw, Machine, #8-32 x 1/2"	4
58	308P120*	Screw, Machine, #8-32 x 5/8" (sltrshd)	4
59	308P124*	Screw, Machine, #8-32 x 1/2" (one-way)	1
60	308P143*	Nut, Hex, KEPS, #8-32	2
61	310P136*	Screw, Machine, #10-32 x 1-1/4" (splanhd)	4
62	310P149*	Screw, Machine, #10-32 x 7/8"	2
64	325P170*	Nut, Wing, 1/4-20	1
65	7000542	Rocker Switch, Power On/Off 250V	1
	7000543	Rocker Switch, Power On/Off 120V	1
66	4010166	Switch, Momentary (Green)	1
	4010190	Switch, Momentary (White)	1
67	7000319	Transformer, 115-230/24V	1
68	7000135	Thermostat, Hi-Limit	1
69	4050214	Thermocouple, Type-K	1
70	406P107	Cable Tie	3
71	7000136	Terminal Block, 3-Pole	1
72	7000317	Control Board, Temperature/Timer, 24V, 50/60 Hz	1
74	338P102*	Bolt, Handle Mounting (MS-250 only)	1
79	0011471	Drawer Assy. (Incl. #80-87) (MS-255 only)	1
80	0021283	Drawer Weldment (MS-255 only)	1
81	210K195	Bearing, Roller, SS (MS-255 only) (Incl. #85)	4
82	2100257	Handle (MS-255 only)	1
83	2100264	Guard, Handle (MS-255 only)	1
84	325P132*	Screw, Machine, 1/4-20 x 1/2" (MS-255 only)	2
85	05P2991	Spacer (MS-255 only)	2
86	306P137*	Stud, PEM, #6-32 x 3/8" (MS-255 only)	2
87	306P107*	Acorn Nut, #6-32 (MS-255 only)	2
88	0021237	Liner Weldment (MS-255 only)	1
89	0503536	Drip Pan (All except Mfg. No. 9100933)	1
90	2100118	Guard, Handle	1
91	See page 21 for Strainer Parts Identification.		
2	7000139	Quick Disconnect Insert	1
93	0011413	Liner Assy. (MS-255 only)	1
94	0011370	2" Leg Kit (Incl. #35)	4
94a	210K134	4" Leg Kit (not shown)	1
94b	210K123	4" Leg Kit (optional) (not shown)	1
95	0800359	Trivet, Spatula (MS-250 only)	1
97	7000138	Quick Disconnect Female Kit	1
98	0503429	Support, Generator Upper.	1
99	7000260	Spatula Kit (Incl. #20, 36, 74, 90, 95) (MS-250 only) (9100435/437 Only)	1

***Only available in quantities of 10.**

Exploded Views

Exploded Diagram 1

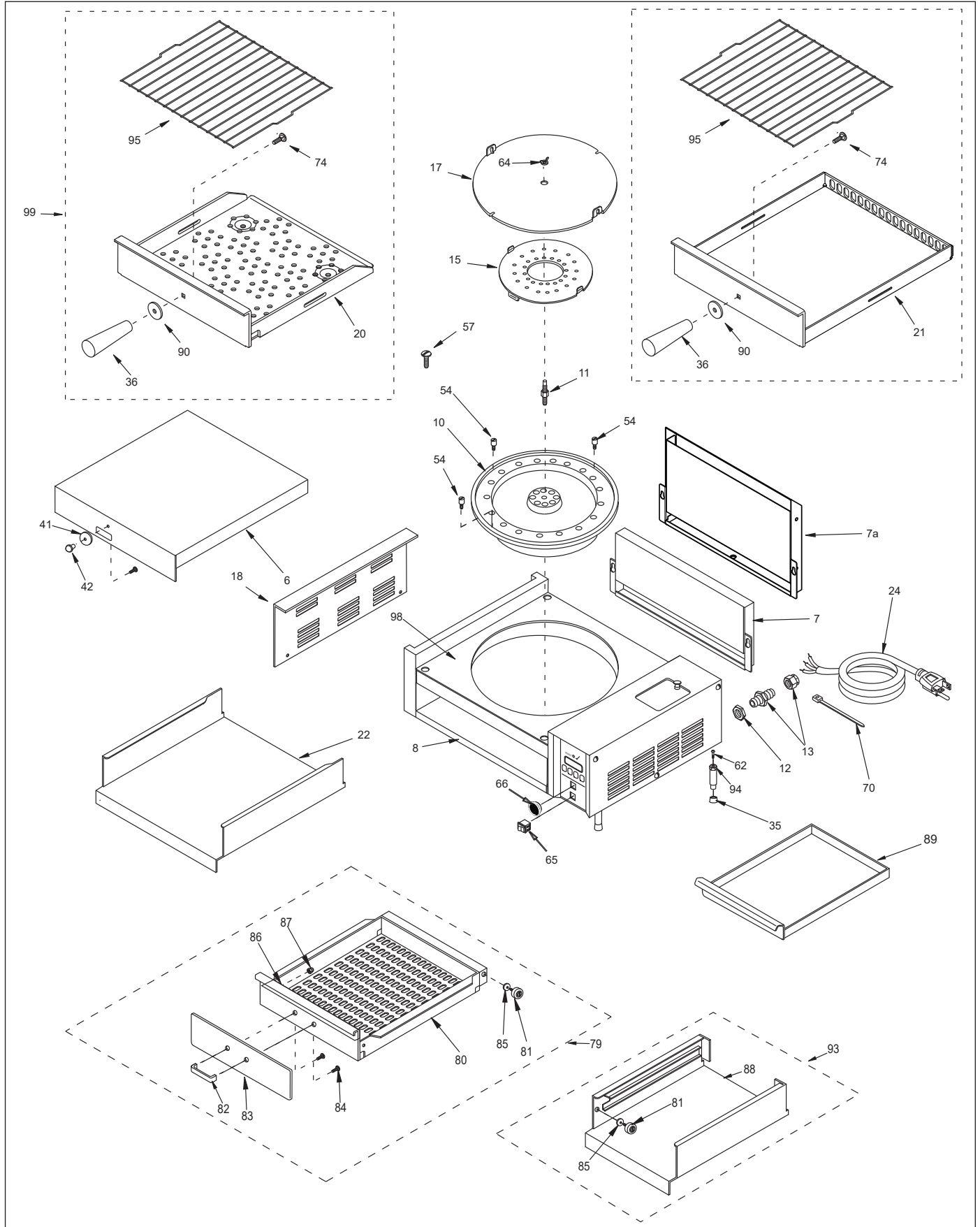

Exploded Views

Exploded Diagram 2

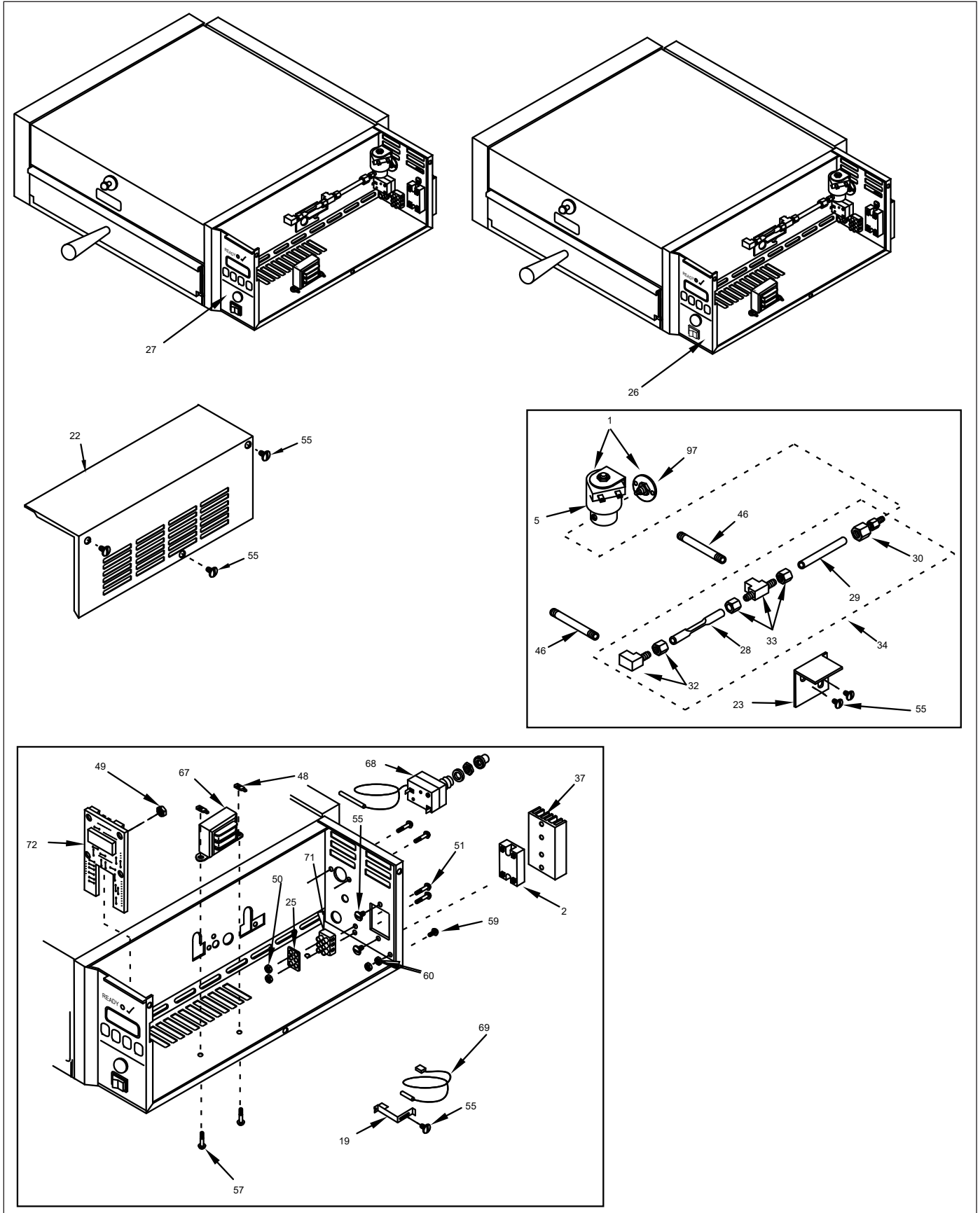

Exploded Views

Exploded Diagram 3

Dual Water Pressure Regulator Kit - Part No. 7000235
(All units except Mfg. No. 9100933)

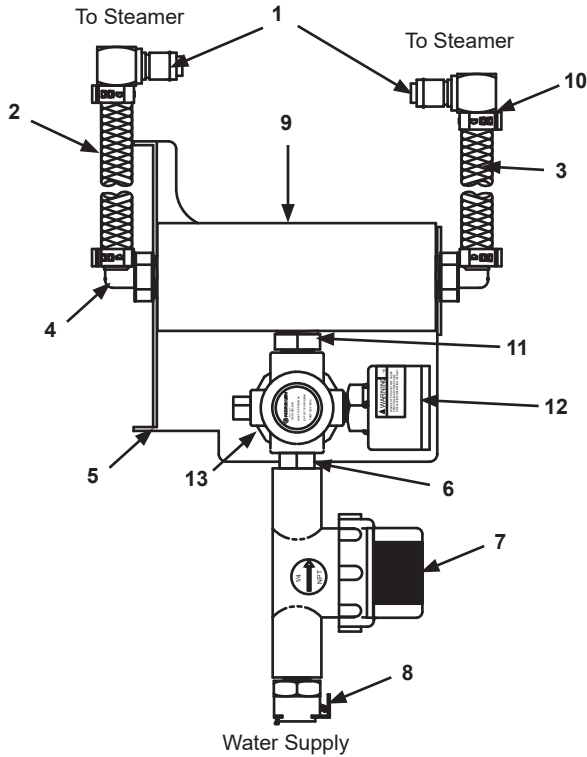

Item No.	Part #	Description	Qty.
1	7000139	Elbow, Quick Disconnect - 1/4"	2
2	2030126	Tubing 1/4" I.D. PVC BRD. 24" Long	1
3	2030125	Tubing 1/4" I.D. PVC BRD. 12" Long	1
4	2040150	Elbow, Male - Nylon 1/4" Barb x 3/8" NPT	2
5	0503615	Bracket, Manifold Mtg.	1
6	2190129	Nipple 1/4" NPT x 1/4" NPT	1
7	7000333	Strainer - 1/4" FPT	1
8	2080118	Quick Disconnect - 1/8" NPT	1
9	2190113	Manifold	1
10	211P104	Clamp, Ear Med.	4
11	2040151	Nipple, Hex - 3/8" x 1/4" NPT Nylon	1
12	7000306	Gauge, Water Pressure	1
13	2170113	Regulator, Pressure	1

NOTE: Two adjacent steamers can be fed with a Dual Water Pressure Regulator.

Single Water Pressure Regulator Kit - Part No. 7000314

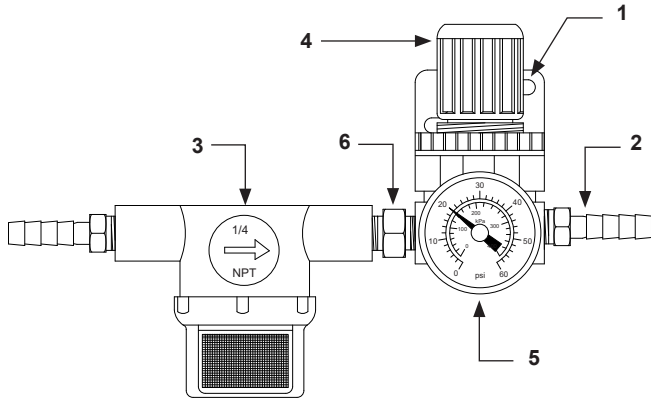

Item No.	Part #	Description	Qty.
1	0503849	Bracket	1
2	2040130	Male Adapter, Barbed 1/4"	2
3	See Below for Strainer Parts Identification		
4	2170113	Regulator, Pressure	1
5	7000306	Gauge, Water Pressure	1
6	2190129	Nipple 1/4" NPT x 1/4" NPT	1
7	211P104	Clamp, Worm (not shown)	2

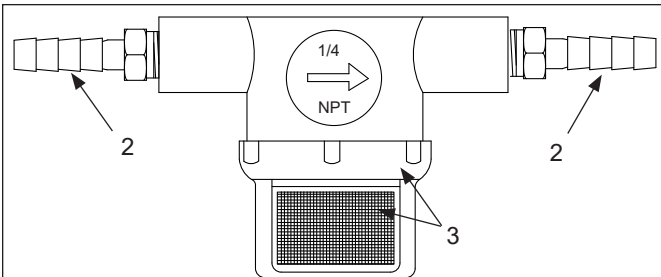

NOTE: Item 1 is made up of Items 2-4.

Item No.	Part #	Description	Qty.
1	7000333	Water Line Strainer Kit	1
2	2040130	Male Adapter, Barbed 1/4"	2
3	7000334	Replacement Screen and O-ring Kit	1
4	211P104	Clamp, Worm (not shown)	2

Wiring Diagram

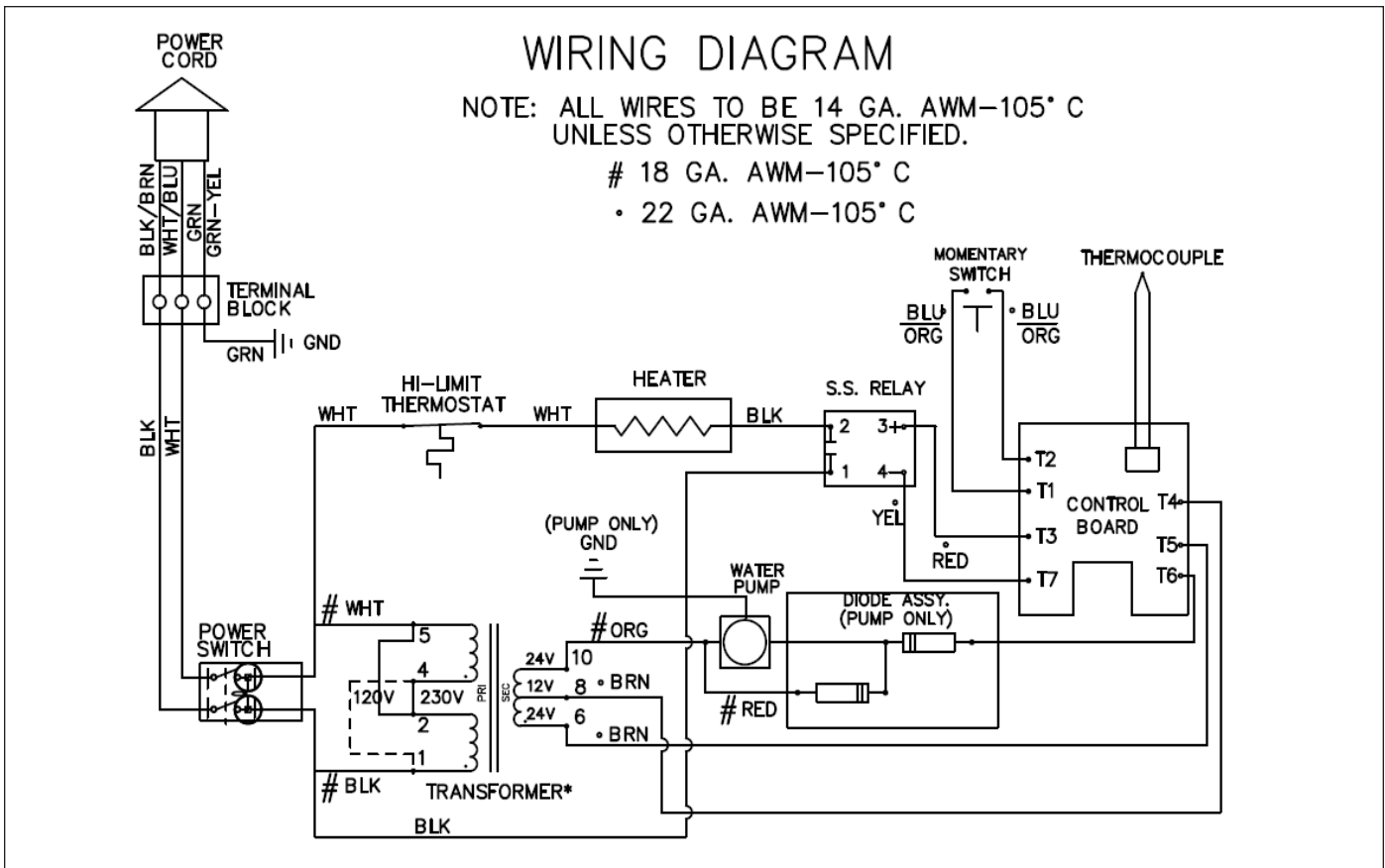

***NOTE:** For 208-240 VAC units, the two primary coils are wired in series with one another.
For 120 VAC units, the two primary coils are wired in parallel with one another.

Notes

Limited Warranty

Equipment manufactured by Antunes has been constructed of the finest materials available and manufactured to high quality standards. These units are warranted to be free from electrical and mechanical defects for a period of one (1) year from date of purchase under normal use and service, and when installed in accordance with manufacturer's recommendations. To insure continued operation of the units, follow the maintenance procedures outlined in the Owner's Manual. During the first 12 months, electro-mechanical parts, non-overtime labor, and travel expenses up to 2 hours (100 miles/160 km), round trip from the nearest Authorized Service Center are covered.

1. This warranty does not cover cost of installation, defects caused by improper storage or handling prior to placing of the Equipment. This warranty does not cover overtime charges or work done by unauthorized service agencies or personnel. This warranty does not cover normal maintenance, calibration, or regular adjustments as specified in operating and maintenance instructions of this manual, and/or labor involved in moving adjacent objects to gain access to the equipment. This warranty does not cover consumable/wear items. This warranty does not cover damage to the Load Cell or Load Cell Assembly due to abuse, misuse, dropping of unit/shock loads or exceeding maximum weight capacity (4 lbs). This warranty does not cover water contamination problems such as foreign material in water lines or inside solenoid valves. It does not cover water pressure problems or failures resulting from improper/incorrect voltage supply. This warranty does not cover Travel Time & Mileage in excess of 2 hours (100 miles/160 km) round trip from the nearest authorized service agency.
2. Antunes reserves the right to make changes in design or add any improvements on any product. The right is always reserved to modify equipment because of factors beyond our control and government regulations. Changes to update equipment do not constitute a warranty charge.
3. If shipment is damaged in transit, the purchaser should make a claim directly upon the carrier. Careful inspection should be made of the shipment as soon as it arrives and visible damage should be noted upon the carrier's receipt. Damage should be reported to the carrier. This damage is not covered under this warranty.
4. Warranty charges do not include freight or foreign, excise, municipal or other sales or use taxes. All such freight and taxes are the responsibility of the purchaser.
5. This warranty is exclusive and is in lieu of all other warranties, expressed or implied, including any implied warranty or merchantability or fitness for a particular purpose, each of which is hereby expressly disclaimed. The remedies described above are exclusive and in no event shall roundup be liable for special consequential or incidental damages for the breach or delay in performance of this warranty.



Corporate Headquarters
Carol Stream, IL, USA
Phone: +1.630.784.1000
Toll Free: +1.800.253.2991
Fax: + 1.(630).784-1650

China Facility
Suzhou, China
Phone: +84.512.6841.3637
Fax: +86.512.6841.3907

India Facility
Chennai, India
Phone: +91.44.25532212
Fax: +91.44.25532415