

# **SENOVEN<sup>®</sup>**

**MODEL  
SEN 1502  
BLOWING CONVEYOR OVEN  
(DIGITAL SCREEN)**

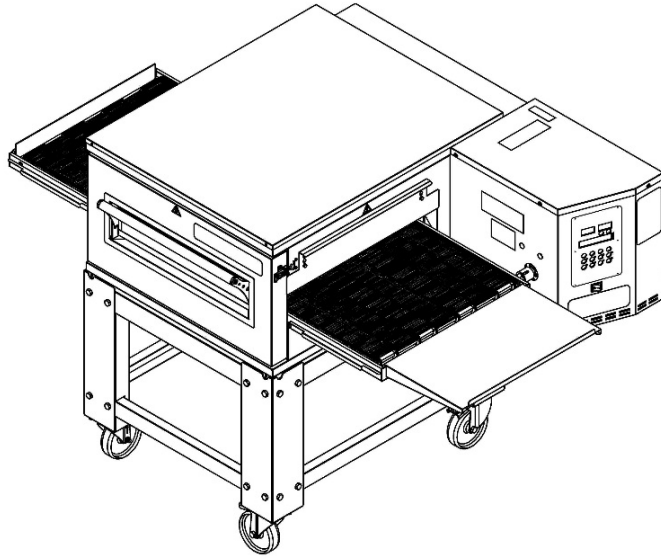

## **USER & MAINTENANCE MANUAL**

**ŞENGÜN MAKİNA İNŞAAT ve KIRTASIYE SAN. TİC. LTD. ŞTİ**

**These instructions apply only if the country code is shown on the device. If the country code does not appear on the device, refer to the technical instructions that give instructions for adapting the device to the country.**

**This device must be installed in accordance with regulations. Refer to the instructions before installing and using the device.**

## WARRANTY CERTIFICATE



SERIAL NUMBER :

SALE DATE :

Sold at the above date **SEN 1502 MODEL BLOWING CONVEYOR OVEN** is guaranteed against production failures for **1 Year** by **ŞENGÜN MAKİNA İNŞAAT ve KIRTASIYE SAN. TİC. LTD. ŞTİ.**

### Warranty Terms;

- Warranty terms start after the product delivery for 1 year.
- Recommended daily working time is 10 hours. The scope of warranty is assessed by year or by working hours.
- Documents are invalid, if haven't sale date and confirm signature of company. You have to show the warranty certificate to benefit from the warranty.
- Device is guaranteed against defects if mount and use as described in the use and maintenance manual.
- Detection the location of defects, and elimination of the problems are responsibilities of the **ŞENGÜN MAKİNA...**
- Warranty terms include only one device. You can't claim any rights or compensation for another devices.
- If Changes are made at the type, model and serial numbers, the warranty eliminates.
- If material, worker or assembly defects appear, repaired free by **ŞENGÜN MAKİNA** at the product warranty period (Transportation cost is not included).
- Failures are only repaired by **ŞENGÜN MAKİNA's** personal. The intervention of unauthorized person, cancel the appliance of warranty.
- Installation have to be done by **ŞENGÜN MAKİNA's** personal. If usage place changes, customer must give information to **ŞENGÜN MAKİNA**
- In the event of failure service must be informed.
- The failures and damages given by external factors are out of the warranty terms.
- Any failure of the product warranty period is added to the product warranty time. The repair time is until 20 working days.
- Istanbul courts are competent in case of dispute.

**AUTHORIZED PERSON**

**STAMP –SIGNATURE**

## PRESENTATION

Dear Users,

Thank you for your prefer our machine and confidence in our company. Our machines are used in 39 countries.

Our machine is manufactured according to international standards. Please read the operating manual to get the mast out of your machine .Please note the following warnings before calling our service.

**ŞENGÜN MAKİNA**

---

---

- Please read the manual carefully before installing the machine.
- The machine will be out of warranty when your operate the machine with at read.
- Please read carefully the manual that gives you information on the installation is prepared in accordance with the legal regulations before arriving at the machine installation.
- For information you coo not understand , ask your nearest out horized service
- Please note that if the technical service personnel is kept waiting you will be billed for each hour.

## IMPORTANT WARNINGS AND SAFETY INFORMATIONS



**WARNING:** This manual contains important safety and installation-operation instructions. Require all operators to read this manual thoroughly before installing, operating or servicing this equipment. Improper installation, adjustment, alteration, service or maintenance can cause property damage, injury or death.



**WARNING:** This appliance is not intended for use by young children or infirm persons unless they have been adequately supervised by a responsible person to ensure that they can use the appliance safely. Young children should be supervised to ensure that they do not play with the appliance.



**WARNING:** Improper installation, adjustment, alteration, service or maintenance can cause property damage, injury or death. Read the installation, operating and maintenance instructions thoroughly before installing or servicing this equipment.



**WARNING!** Do not work around conveyor belt with long hair, loose clothing, or dangling jewelry. Getting caught in the belt could result in serious injury.



**WARNING!** For your safety, do not store or use gasoline or other flammable vapors or liquids in the vicinity of this or any other appliance.



**WARNING!** If the power supply cord damaged, do not attempt to operate the unit. Contact a service agent or qualified electrician to repair!



**WARNING!** Do not use paper when placing food product through the oven! Usage of flammable materials may cause a fire and should never be placed in the oven.



**WARNING!** Do not put any object to anywhere of the oven except the conveyor.



**WARNING!** Always be careful while you are working.

- The oven must be placed under a ventilator to provide for adequate air supply.
- Minimum clearances must be provided from all walls and combustible materials. Look “spacing requirements” section for more information.
- Always keep the oven clean and clear combustible materials.
- Keep adequate clearance for air openings.
- Do not obstruct the ventilation holes.
- The oven is to be operated only on as shown on the specification plate.
- This manual should be retained for future reference.
- Prepare a list of what you should do when you smell gas and keep it near the oven.
- Gas does not pass through the burner without electricity.

### **Responsibilities of the Purchaser Company**

Responsibilities of the purchaser company are written at bottom;

- To see that the electric and gas services for the oven are installed in accordance with the manufacturers specification.
- Installing the oven and placing it as suggested at the catalogue.
- To see that the electric services are connected properly by a qualified installer of your choice.

## **WARNING**

**Cleaning and maintenance are the most important factors of oven performance. The processes which are not available in the manual can cancel the appliance of warranty, cause property damage, injury or death. Read and understand the instructions in the manual**

# CONTENTS

## WARRANTY CERTIFICATE

## PRESENTATION

### SECTION 1: INTRODUCTION

- 1.1 Introduction of Body Components
- 1.2 Functions of Parts
  - 1.2.1 Oven Body
- 1.3 Overlap Assembly
- 1.4 Microprocessor Control
- 1.5 Cooking Function
- 1.6 Conveyor (Belt)
- 1.7 General Information
- 1.8 Oven Specifications
- 1.9 Electrical and Technical Specifications Table
- 1.10 Dimensions

### SECTION 2: ASSEMBLE

- 2.1 Product Out Sheet
- 2.2 Front/Back Waste Collecting Sheet
- 2.3 Entry and Exit Cover Sheet
- 2.4 Stopper Sheet (Optional)
- 2.5 Belt Assembly
- 2.6 Belt Wire Assembly
- 2.7 High Chassis Assembly
- 2.8 Low Chassis Assembly
- 2.9 Chassis-Oven Assembly
- 2.10 Double Floor Oven Assembly
- 2.11 Triple Floor Oven Assembly
- 2.12 Air Duct Disassembly / Assembly

### SECTION 3: INSTRUCTIONS FOR USE

- 3.1 Distance Requirements
- 3.2 Ventilation
- 3.3 General Information of Ventilation

- 3.4 Ventilation Advice
- 3.5 Gas Connection
- 3.6 Installation Elements
- 3.7 SEN 1502 Oven Technical Specifications Table

## **SECTION 4: PROGRAMMING-START & STOP**

- 4.1 Warnings
- 4.2 Closing
- 4.3 Fault / Warnings Messages
- 4.4 Burner Fault
- 4.5 Functions
  - 4.5.1 Temperature Cutting Switch
  - 4.5.2 Electrical Installations
  - 4.5.3 Limitation Requirements – Gas Ovens
  - 4.5.4 Operator Maintenance
  - 4.5.5 Cleaning Instructions
  - 4.5.6 Protective Maintenance

## **SECTION 5: COOKED PRODUCTS**

- 5.1 Some of The Cooked Products
- 5.2 Cooking Time and Temperature
- 5.3 Total Cooking Calculation
- 5.4 Sample Capacity Table

## **SECTION 6: SPARE PARTS MANUAL**

## **SECTION 7: ELECTRICAL DIAGRAM**

## **SECTION 8: TROUBLESHOOTING**

- 8.1 Products are Not Cooking
- 8.2 How to Call Technical Service?

## **SECTION 9: LABELS**

## **NOTES**

# SECTION 1: INTRODUCTION

## 1.1 Introduction of Body Components:

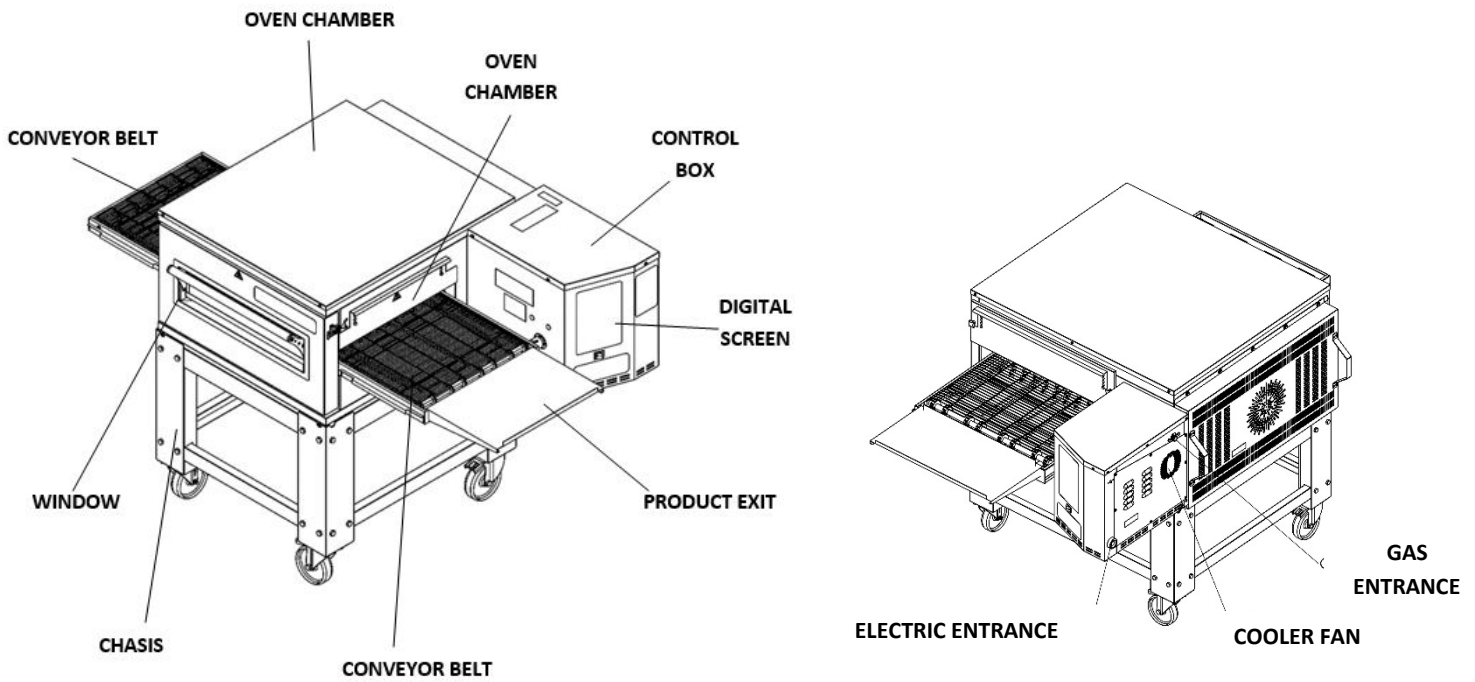

**NOTE:** Entrance of product depends for the cooking style. The out sheet can be attached other side of the oven.

## 1.2 Functions of Parts:

### 1.2.1 Oven Body:

Every SEN series oven has a main body.

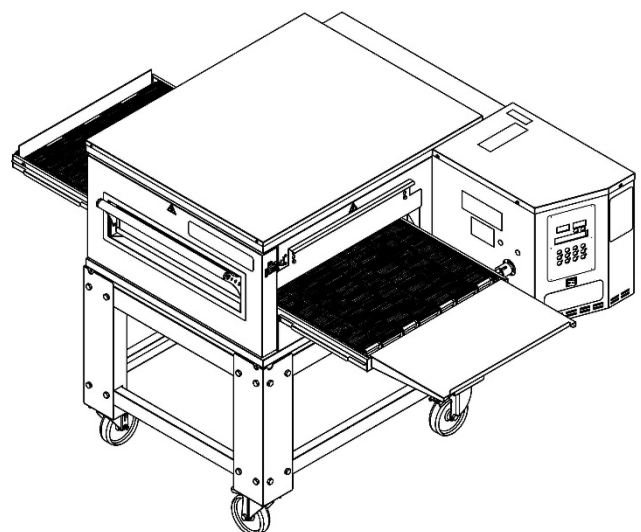

### 1.3 Overlap Assembly:

SEN series ovens can be used to overlap two or three. The ovens assembled to the chassis and connect each other.

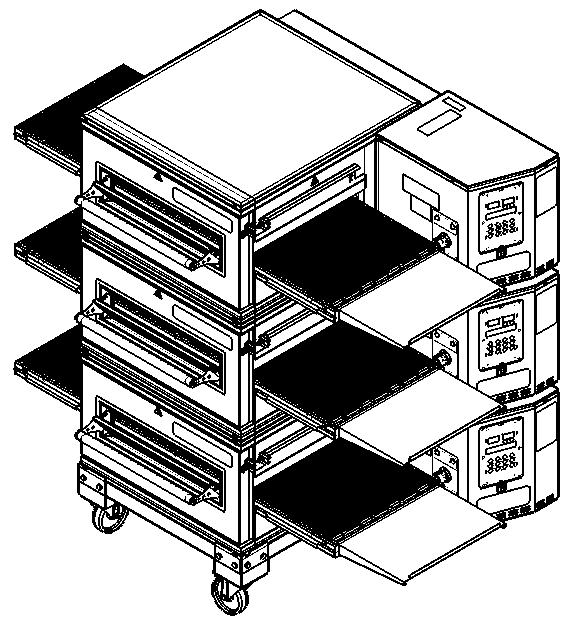

### 1.4 Microprocessor Control:

Every single oven is controlled by separate programmable microprocessor. The microprocessor controls all functions of the oven. Oven temperature can be set between 150°C to 300°C. And the cooking time can be set between 1 - 30 minutes. Standby Mode provides energy saving. Also service module helps to the technicians. You can cook standard and delicious products in a short time.

### 1.5 Cooking Function:

The oven cooks the products standard and delicious by circulating compressed air.

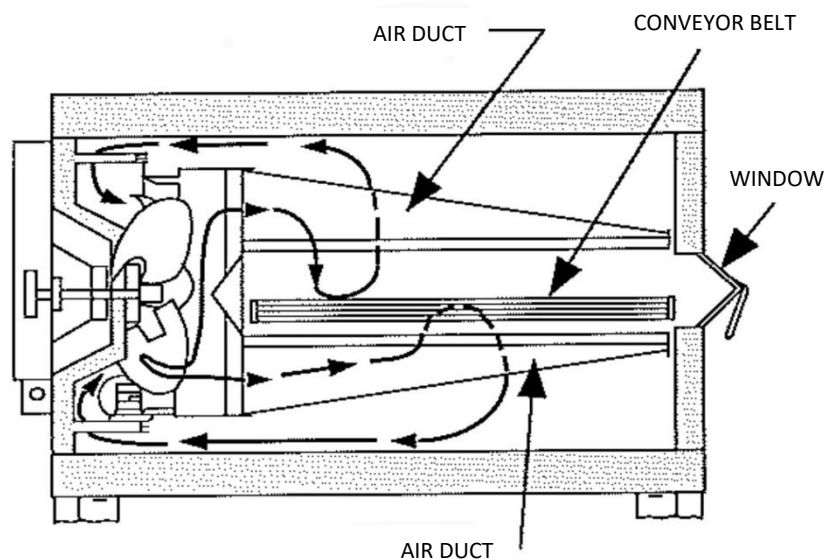

### 1.6 Conveyor (Belt):

Conveyors provide the input and output of the product. Belt is controlled by microprocessor. Cooking time can be set between 1 - 30 minutes. The speed of belt determines the Products cooking time. The width of belt is 455 mm and consist by interlocking wires.

## 1.7 General Informations:

- Informations which are located at the following pages will guide you at installation of the oven.
- First of all check the parts of oven carefully.
- Before the installation determine a safety place for oven.

## 1.8 Oven Specifications:

	<b>SEN 1502</b>
Conveyor Belt Width :	455 mm
Heating Chamber Length :	710 mm
Heating Chamber Size :	L 710 mm X W 486 mm x H 72mm.
Conveyor Cooking Area :	0,34 m <sup>2</sup>
Overall Dimensions for Single Oven :	Oven Width: 1043 mm Oven Height: 450 mm Total Long: 1710 mm
Overall Dimensions for Double Oven :	L 1710 x W 1043 x H 1165,5
Overall Dimensions for Triple Oven :	L 1710 x W 1043 x H 1615,5
Chassis Dimensions of the Single and Double Oven - Weight :	L 805 mm x W 720 mm x H 620 mm – 22,8 kg
Chassis Dimensions of Triple Oven - Weight :	L 805 mm x W 720 mm x H 265,5 mm – 14 kg
Weight :	126 kg
Transportation Single Oven Weight – Domestic (Machine + Chassis + Packing) :	187,3 kg
Transportation Single Oven Weight – Abroad (Machine + Chassis + Packing) :	195,8 kg
Transportation Size (Domestic) :	L 1530 mm x W 1165 mm x H 675 mm
Transportation Size (Outland) :	L 1470 mm x W 1110 mm x H 680 mm
Average Gas Usage :	0,65 m <sup>3</sup> / hour
Usage of gas :	1,375 m <sup>3</sup> / hour
Capacity :	13 kW
Allowable Temperature Range :	150 °C – 300 °C
Conveyor Drive System :	208 - 300 Volt Microprocessor Conveyor control system
Cooking Time :	1 min – 30 min Adjustable
Insulation :	4 Side
Heat Source :	1 Burner
Oven Chamber :	Steel (Galvanized)
Steel Enclosure :	430 Stainless Steel
DB Level :	< 65 dba
Source :	Electricity and Gas

**NOTE:** Burner does not heat the oven every moment. Because Oven Protects chamber temperature. If the chamber temperature is enough, burner shuts down.

## 1.9 Electrical and Technical Specifications Table:

## Electrical and Technical Specifications Table

Voltage	Faze	N	T (PE)	Ampere Loading	Gas Inlet Pressure	Capacity (Kw)	Full Performance Gas Usage	Average Gas Usage	BTU
230V 50/60HZ	1	1	1	2	21 mbar	13 kW	1,375 m <sup>3</sup> / hour	0,65 m <sup>3</sup> / /hour	40,000 /hour

**Power Supply:** Mono FAZE, 230 V AC, 50/60Hz / 2 Amp: 1Nötr, 1 Grounding

IMPORTANT: Electrical input connection must be connected according to the order of the input terminals.

(PHASE TO PHASE, NEUTRAL TO NEUTRAL, – GROUNDING TO GROUNDING)

**NOTE:** Specifications can be changed by Şengün Makina. Above Specifications are given for information.

---

### 1.10 Dimensions:

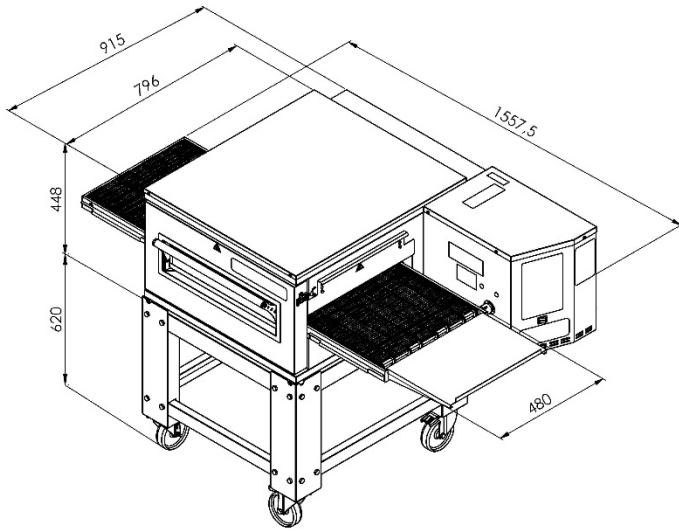

**Single Oven  
(Isometric)**

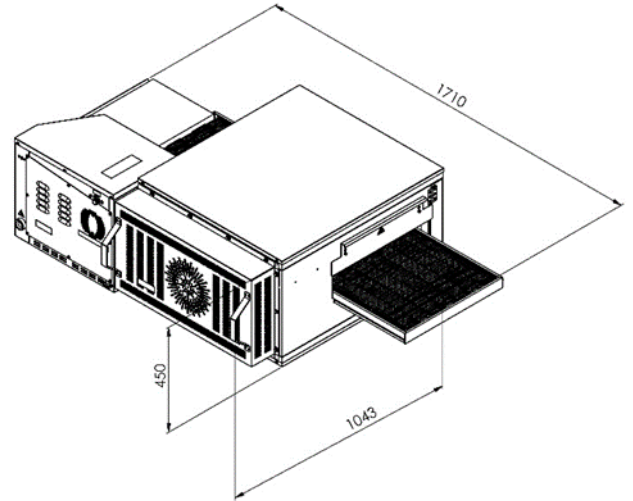

**Dimensions Outside**

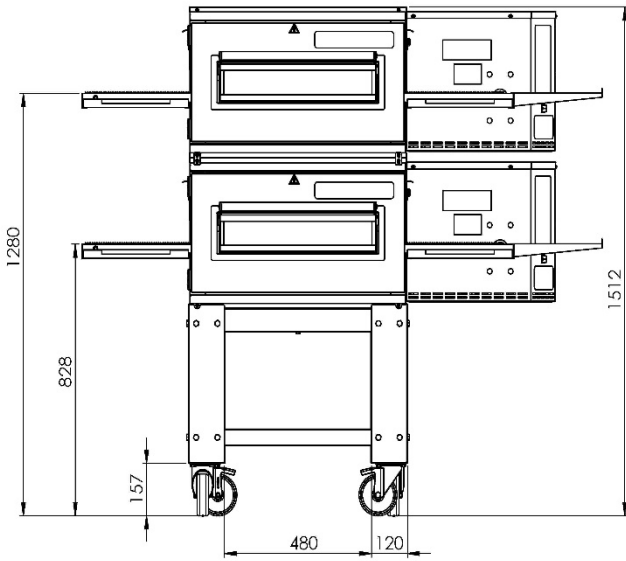

**Duplex  
(Side View)**

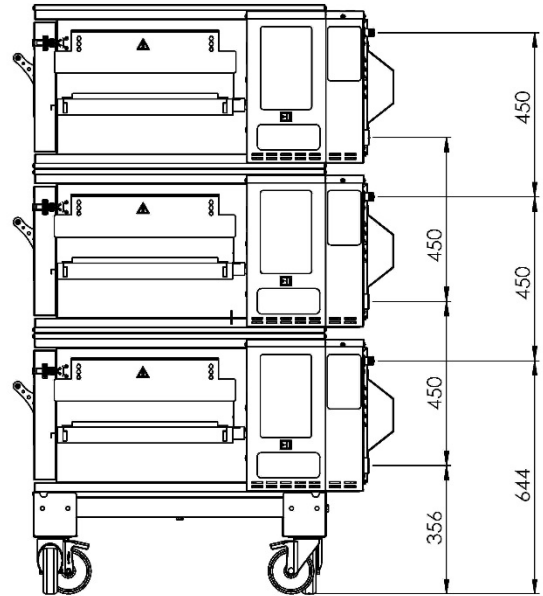

**Front View**

**ELECTRICITY**

**GAS**

**GAS ENTRANCE DIMENTIONS**



**Triplex  
(Side View)**

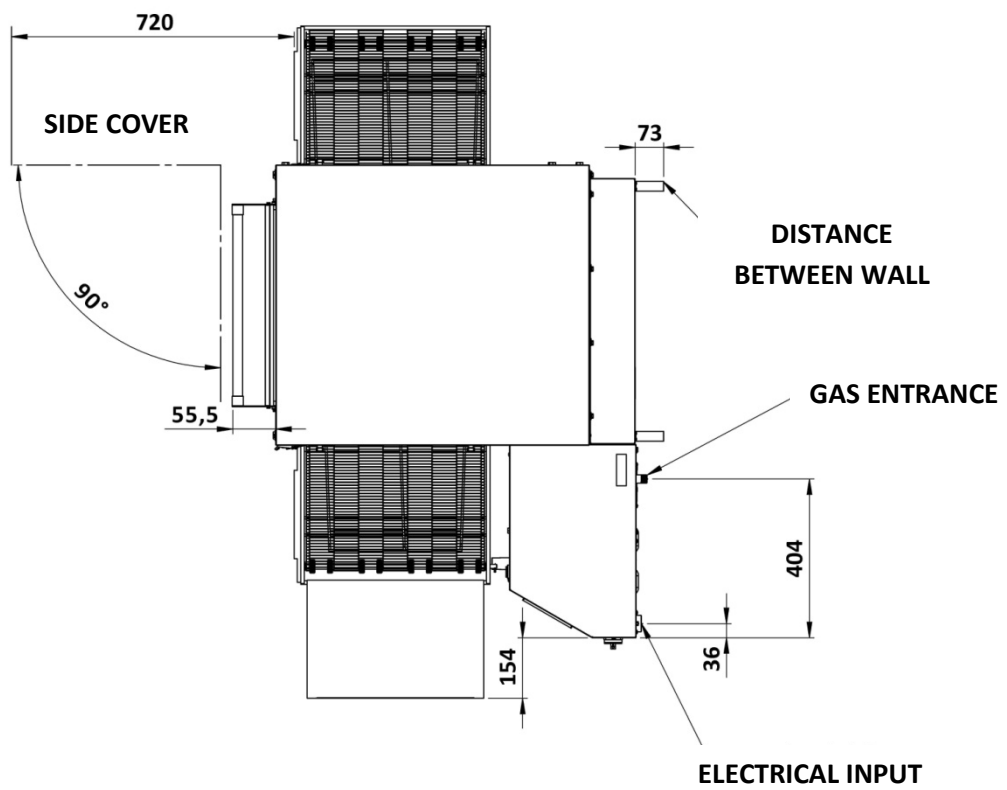

**Top View**

---

**SECTION 2: ASSEMBLE**

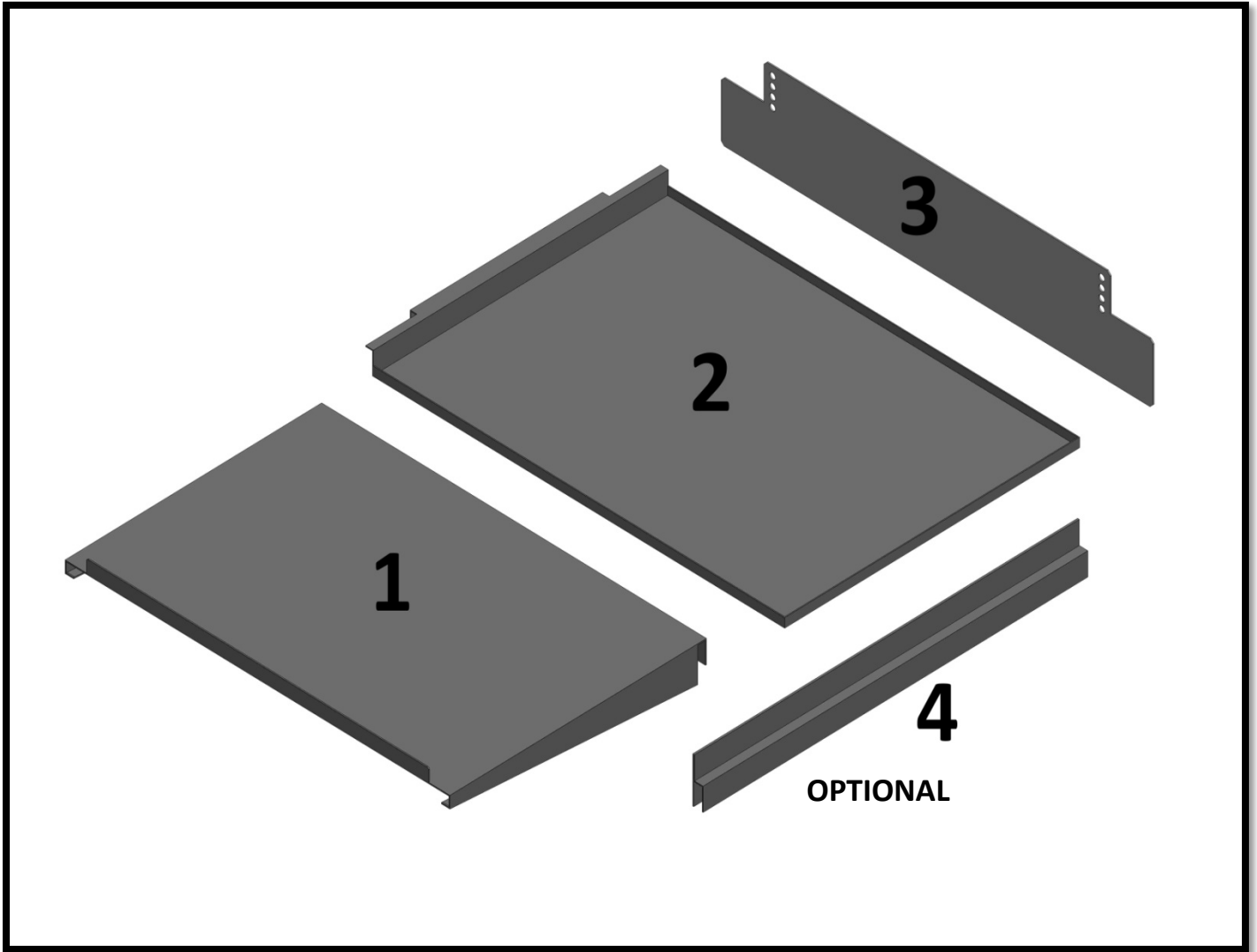

NO	PART NAME	UNIT
1	Product Out Sheet	1
2	Forward/Back Waste Collecting Sheet	2
3	Entry and Exit Cover Plate	2
4	Stopper Sheet (Optional)	1

---

## 2.1 Product Out Sheet:

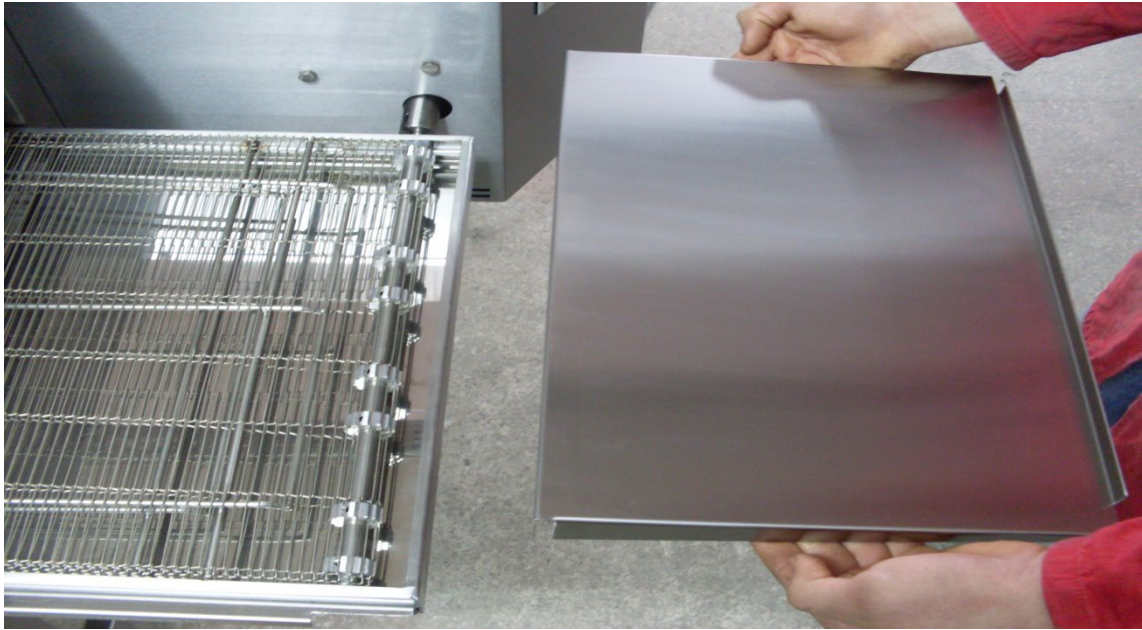

Attach the product out sheet to the conveyor chassis as shown in the figure. And Push it.

## 2.2 Front/Back Waste Collecting Sheet:

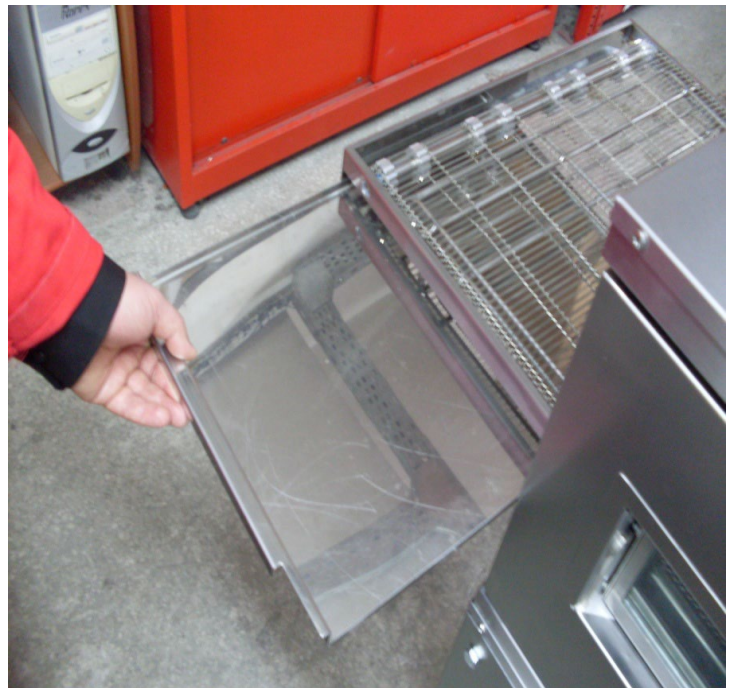

Front and back waste collecting sheets are taken out as shown in pictures.

---

## 2.3 Entry and Exit Cover Sheet:

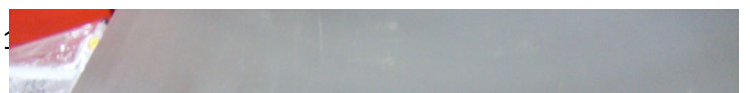
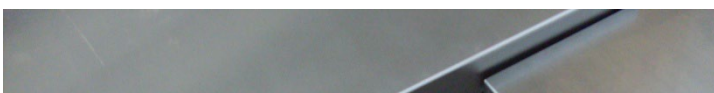

Covers are set as desired through holes which are different levels. Covers are attached by bakelite bolts.

#### **2.4 Stopper Sheet (Optional):**



Stopper, blocks the products and keep them into the belt. Stopper is attached to the belt.

---

#### **2.5 Belt Assembly:**



The conveyor is mounted inside the machine as shown in the picture.



The drive shaft is centered on the clutch pipe.



Clutch pipe is attached by the drive shaft spring as shown in the figure.



Belt assembly is completed. For disassembly, use every step in reverse order.

---

## 2.6 Belt Wire Assembly:

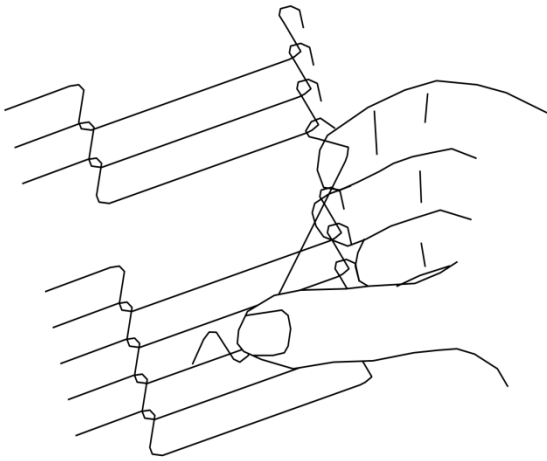

1. Installed as shown in the figure. (Edge connecting wire left and right)

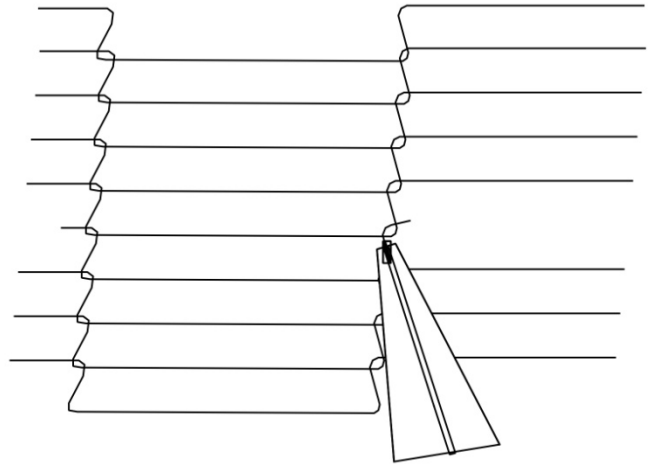

2. Attached by pliers (Middle connecting wire)

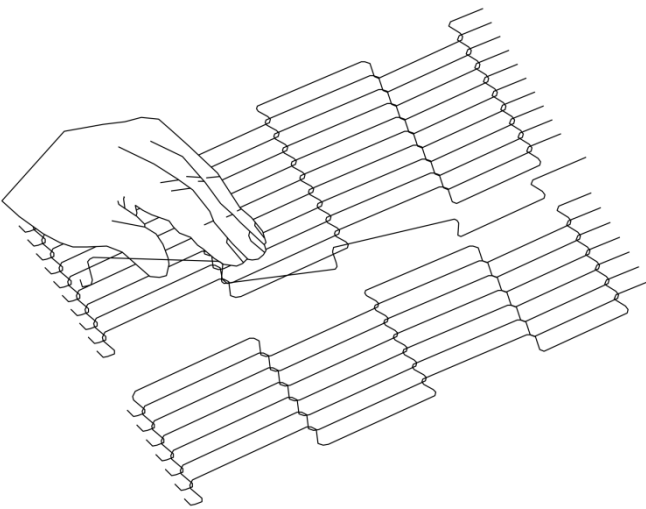

3. If belt wire problem appears, remove a wire as shown in the figure.

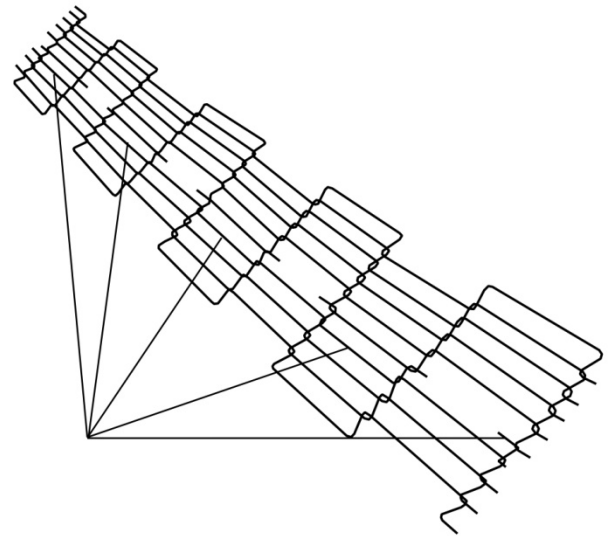

4. The final wire assembly

For disassembly, use every step in reverse order.

**NOTE:** Clean the belt wire once a week or month for better performance.

## 2.7 High Chassis Assembly:

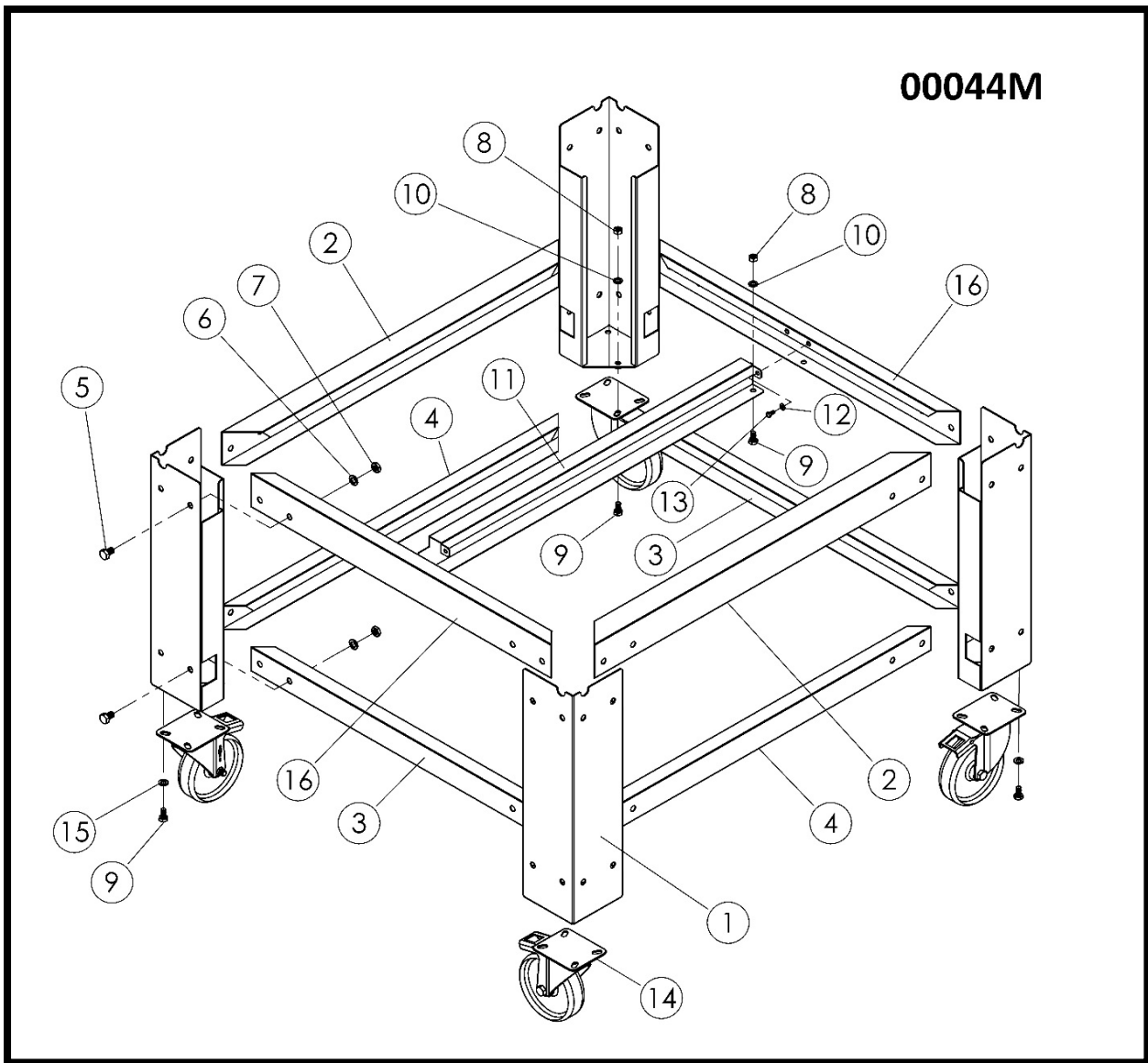

**SEN 1502 HIGH CHASSIS (L 805 mm x W 720 mm x H 620 mm) SPARE PARTS LIST**

ITEM	SPARE PART NUMBER	SPARE PARTS DESCRIPTION	UNIT	ITEM	SPARE PART NUMBER	SPARE PARTS DESCRIPTION	UNIT
1	01981	CHASSIS LEG SHEET	4	9	01957	BOLT	18
2	01980	BRACKET SHEET	2	10	01961	WASHER	18
3	01977	BRACKET SHEET	2	11	01978	BRACKET SHEET	1
4	01976	BRACKET SHEET	2	12	00051	WASHER	2
5	01958	BOLT	32	13	00048	BOLT	2
6	01960	WASHER	32	14	01964	WHEEL	4
7	01965	NUT	32	15	01963	WASHER	16
8	01959	NUT	18	16	00043M	BRACKET SHEET GROUP	2

## 2.8 Low Chassis Assembly:

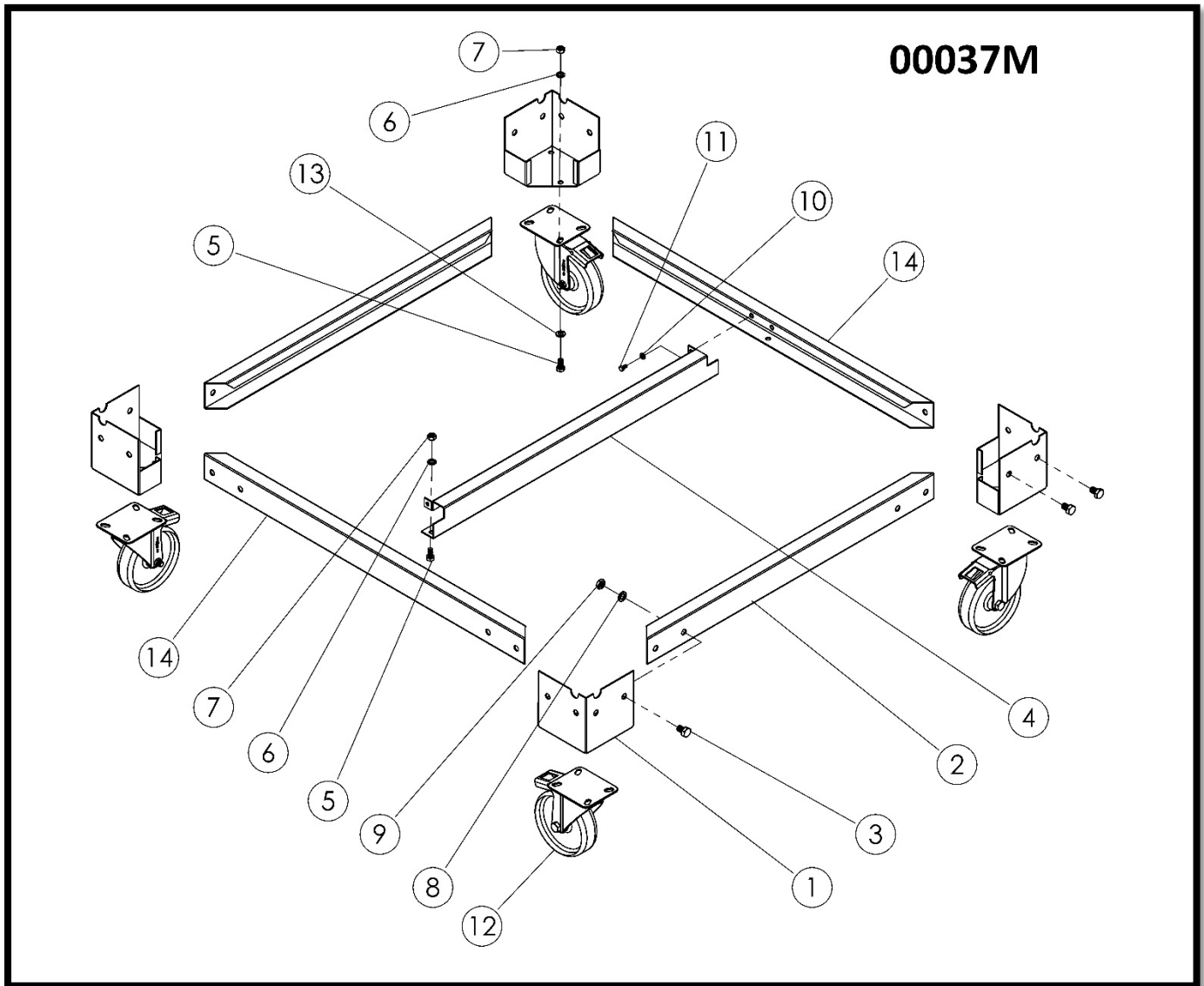

### SEN 1502 LOW CHASSIS (L 805 mm x W 720 mm x H 265,5 mm) SPARE PARTS LIST

ITEM	SPARE PART NUMBER	SPARE PARTS DESCRIPTION	UNIT	ITEM	SPARE PART NUMBER	SPARE PARTS DESCRIPTION	UNIT
1	01797	CHASIS LEG SHEET	4	8	01960	WASHER	16
2	01809	BRACKET SHEET	2	9	01965	NUT	16
3	01958	BOLT	16	10	00051	WASHER	2
4	01842	BRACKET SHEET	1	11	00048	BOLT	2
5	01957	BOLT	18	12	01964	WHEEL	4
6	01961	WASHER	18	13	01963	WASHER	16
7	01959	NUT	18	14	00042M	BRACKET SHEET GROUP	2

## 2.9 Chassis-Oven Assembly:

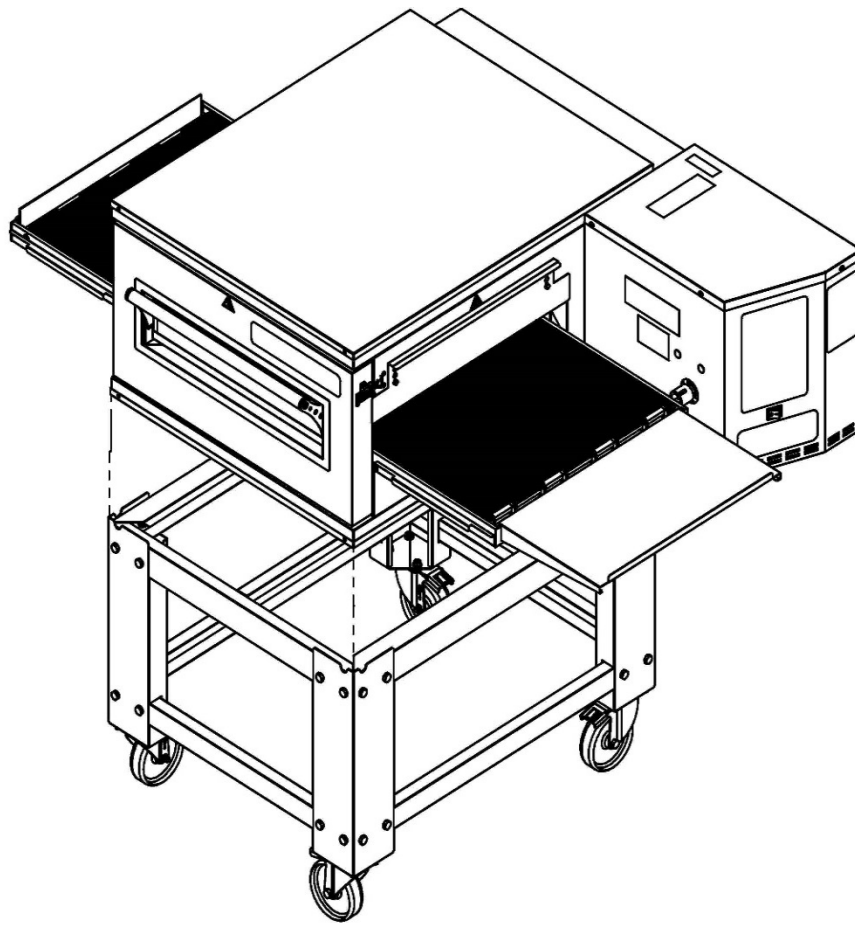

## 2.10 Double Floor Oven Assembly:

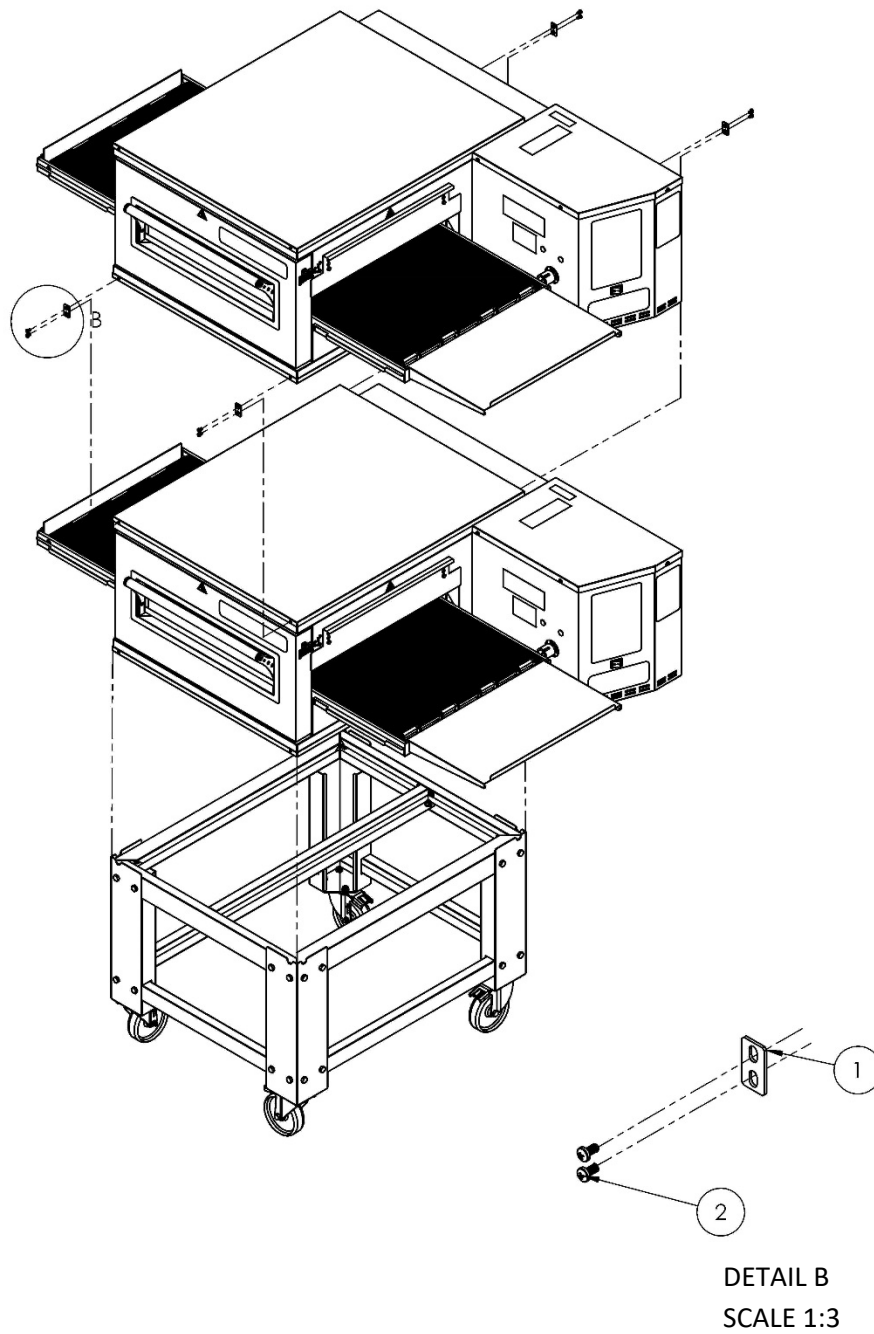

**NOTE:** Bolts are included in the package.

ITEM	SPARE PART NUMBER	SPARE PART DESCRIPTION	UNIT
1	02056	HOLDER	4
2	00046	BOLT	8

## 2.11 Triple Floor Oven Assembly:

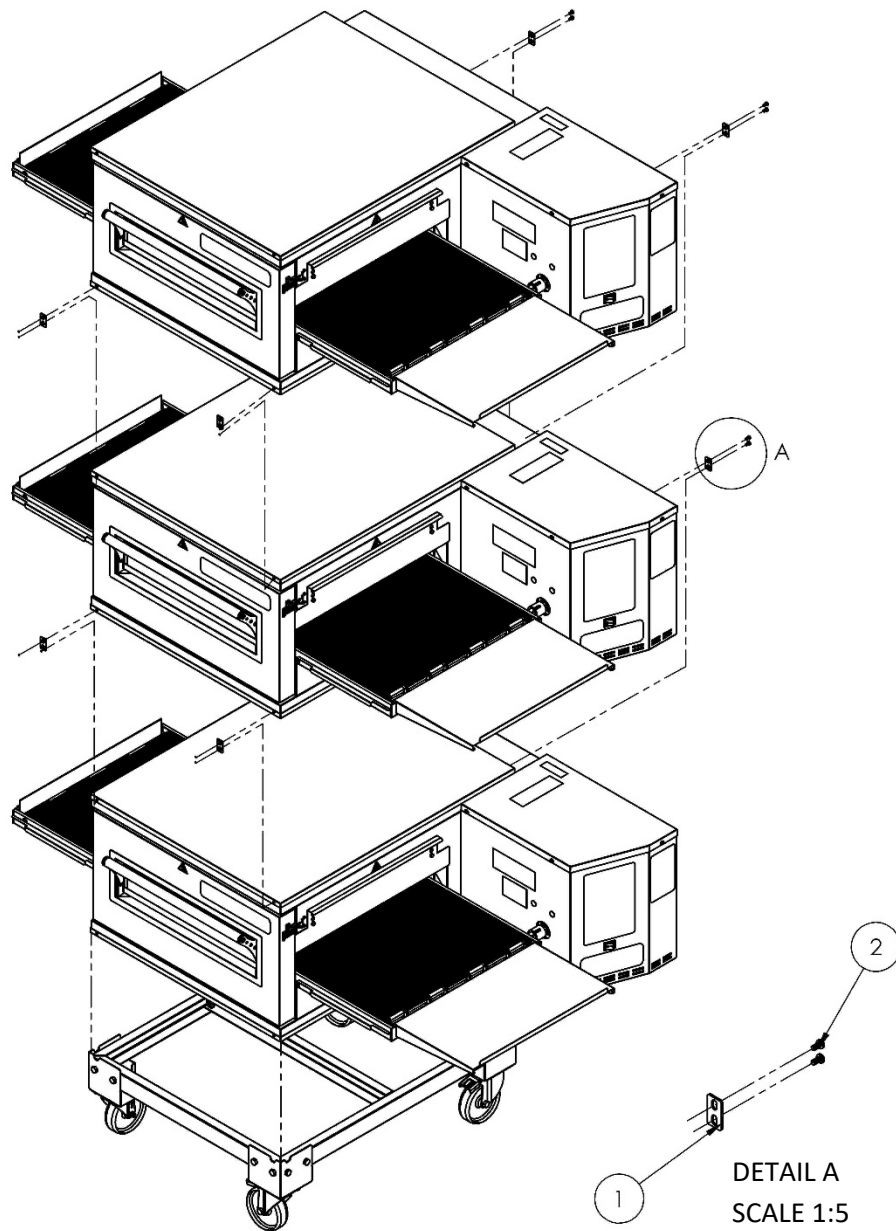

**NOTE:** Bolts are included in the package.

ITEM	SPARE PART NUMBER	SPARE PART DESCRIPTION	UNIT
1	02056	HOLDER	8
2	00046	BOLT	16

## 2.12 Air Duct Disassembly / Assembly:



**WARNING!** Wait for the cooling of the oven.

1. Open the oven cover.

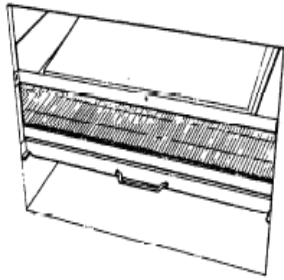

2. Hold the upper air duct guard sheet. Pull up the sheet and pull it.

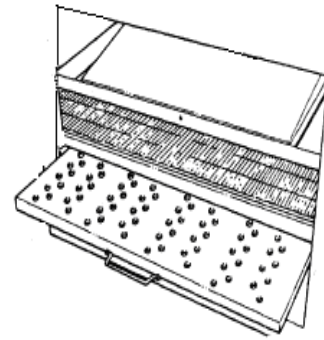

3. Hold the bottom air duct holder and pull it.

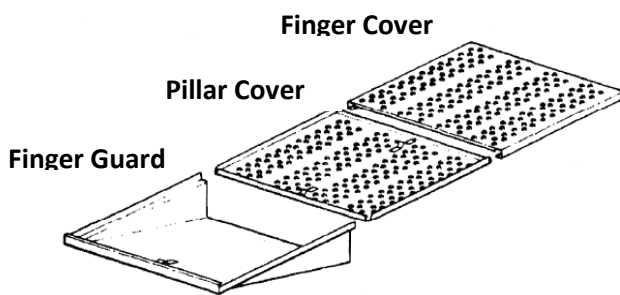

**Bottom Air Duct Assembly**

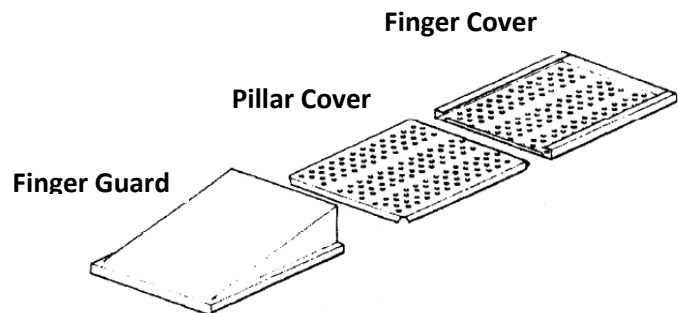

**Upper Air Duct Assembly**

4. Slide the air duct cover and remove the middle sheet.

5. For reassembly, use every step in reverse order.

## SECTION 3: INSTRUCTIONS FOR USE

### 3.1 Distance Requirements:

The oven must have 130 mm of clearance from combustible surfaces. In case other equipment is located on the right side of oven, a minimum clearance of 620 mm is required from that equipment.

**FOR ALL OVENS:** A 620 mm clearance at the rear of the oven must be obtainable for service access.

**FOR FIXED OVENS ANY TIME:** A permanently installed (unmovable) oven requires a minimum of 340 mm clearance on the right-hand side to allow for conveyor removal, cleaning, and servicing.

**NOTE:** Do not install this (these) oven(s) in any area with an ambient temperature in excess of 40° C. Doing so will cause damage to the unit.

### 3.2 Ventilation:

Ventilation is very important especially gas ovens. Determine your ventilation system according to your country fire and safety rules. The information to guide you about the ventilation is in the next section.

### 3.3 General Information About Ventilation:

Ventilation channel or hood should be sufficient to attract heat and cooking odor. In addition, ventilation in gas ovens must be sufficient to expel combustion products. Operation and properly configured ventilation is the responsibility of the furnace owner.

The ventilation mouth (hood) should be in harmony with the general ventilation and heating system.

**ANTENTION:** Do not allow air to flow through the cooking tunnel. The air must not be directed to the front top of the oven, to the side or to the rear.

### 3.4 Ventilation Advice:

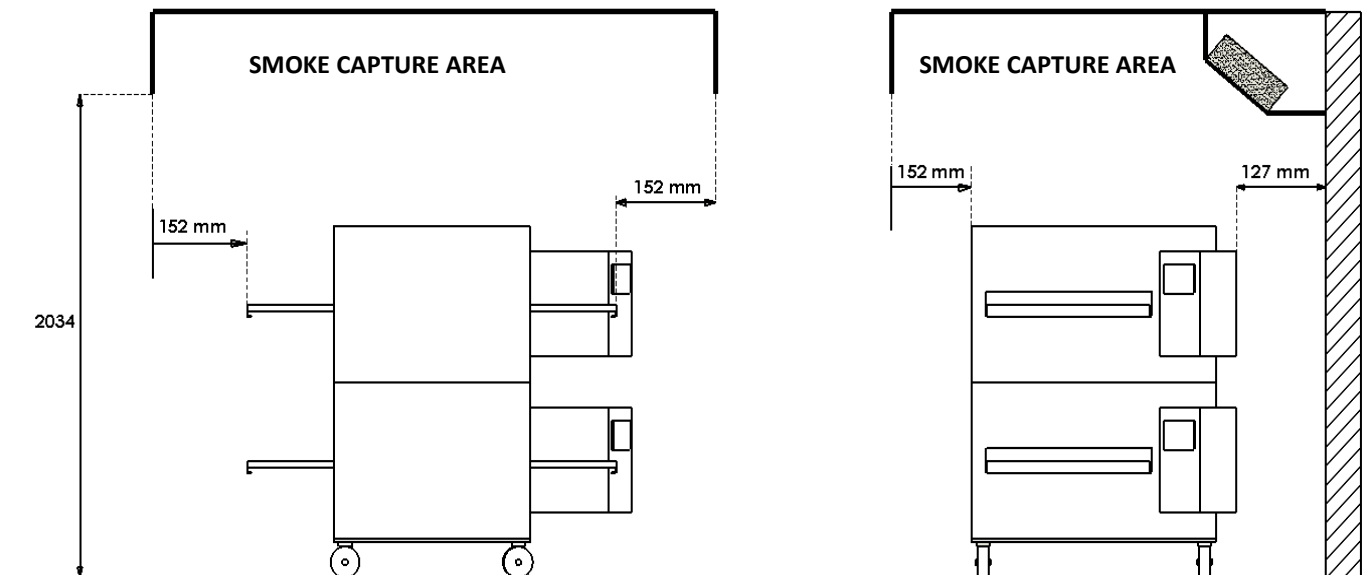

You are ready for services to be connected. This should be done by a qualified electrician, or installer of your choice.

### 3.5 Gas Connection:

Installation of gas connection must be done properly. National gas Law rules are valid.

**DO NOT ATTEMPT TO OPERATE THE OVEN** until connection of utility service and installation has been fully inspected (START-UP CHECKOUT) by an Authorized Service Technician.

This is important service, in order to assure the oven(s) is/are properly installed and in working order. The warranty becomes effective upon verification of proper installation. The warranty shall not apply if the oven(s) is/are started up and operated prior to the "START-UP CHECKOUT" being performed by an Authorized Service Technician.



**DANGER!** Do not work around conveyor belt with long hair, loose clothing, or dangling jewelry. Getting caught in the belt could result in serious injury.



**DANGER!** If the power supply cord appears to be damaged, do not attempt to operate the unit. Contact a service agent or qualified electrician to repair!

### 3.6 Installation Elements:

1 x 10 A (K AUTOMAT) – Fuse

Cable section: 1, 5 mm<sup>2</sup> (TTR Cable – 1 Faze / 1 Neutral / 1 Ground)

**NOTE:** *TTR Cable is Flexible, shatterproof and loosen proof*

Grounding has to be proper.

Use regulator if voltage is high or low.

**NOTE:** *If you fallow the above steps, assembly process can be made smoothly and quickly.*

### 3.7 SEN 1502 Oven Technical Specifications Table

OVEN ELECTRICITY-GAS TECHNICAL SPECIFICATIONS TABLE

Voltage	Faze	N	T (PE)	Ampere Loading	Gas Inlet Pressure	Capacity (Kw)	Full Performance Gas Usage	Average Gas Usage	BTU
230V 50/60HZ	1	1	1	2	21 mbar	13 kW	1,375 m <sup>3</sup> /hour	0,65 m <sup>3</sup> /hour	40,000 /hour

**Power Supply:** Mono FAZ, 230 V AC, 50/60Hz / 3 Amp: 1 Neutral, 1 Ground

IMPORTANT: Electrical input connection must be connected according to the order of the input terminals.

(PHASE TO PHASE, NEUTRAL TO NEUTRAL, – GROUNDING TO GROUNDING)

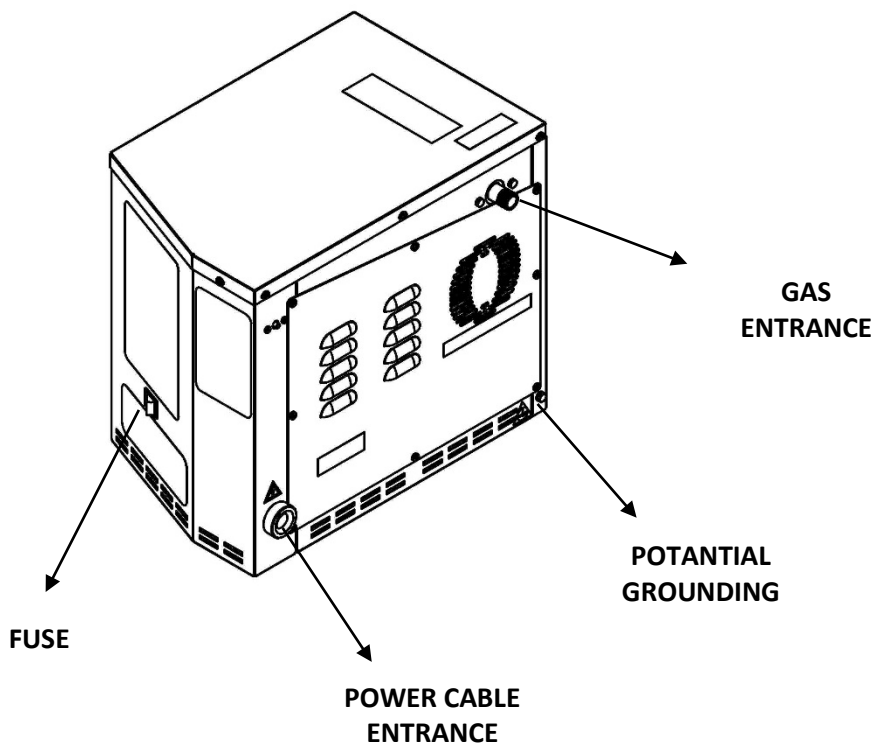
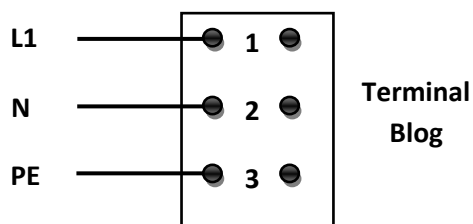

## SECTION 4: PROGRAMMING, OPERATING AND CLOSING

All functions of the oven are controlled by the microprocessor. The oven must be pre-programmed for operation. The following pages are described step by step in programming.

### OVEN CONTROL DEVICE

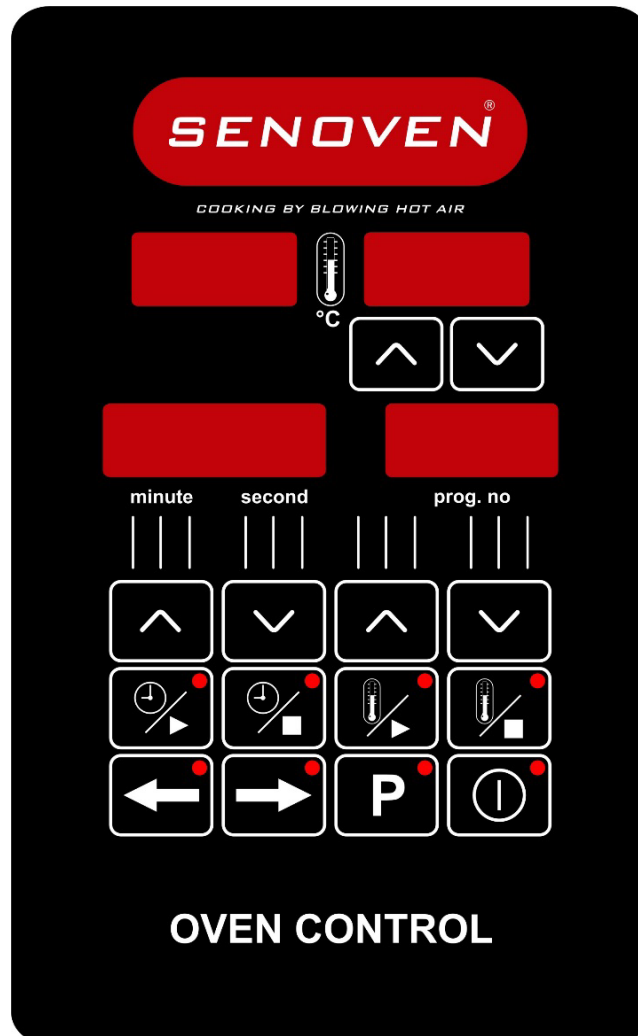

### Working Condition



**Working Temperature:** -20 - 70°C



**Maximum Damp:** %90 Rh (without condensation)



**Height:** Up to 2000 meters



**Environments where device use is not suitable.**

Corrosive atmospheric environments.

Explosive atmospheric environments.

Home applications. (The device only can be used industrial applications.)

# General Features

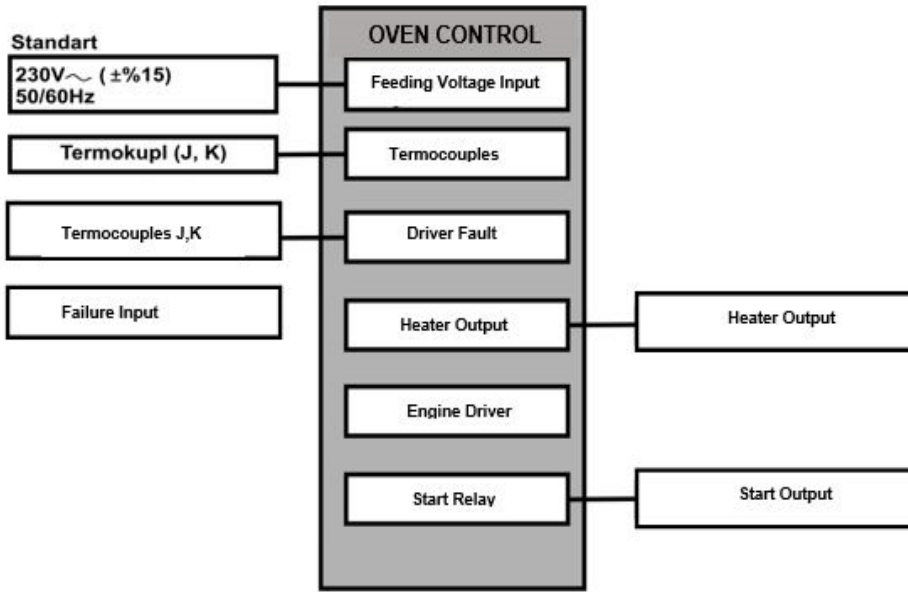

# Electrical Connection Shema

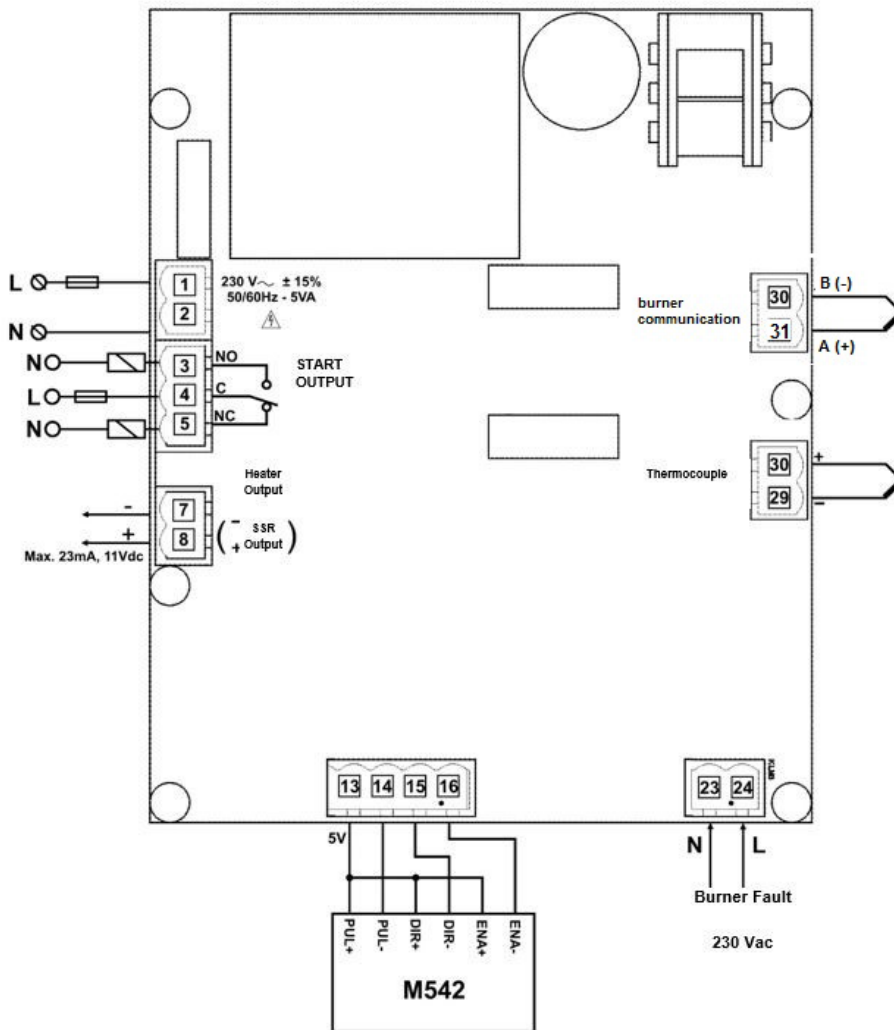

## Oven Control Device Front Panel Definition

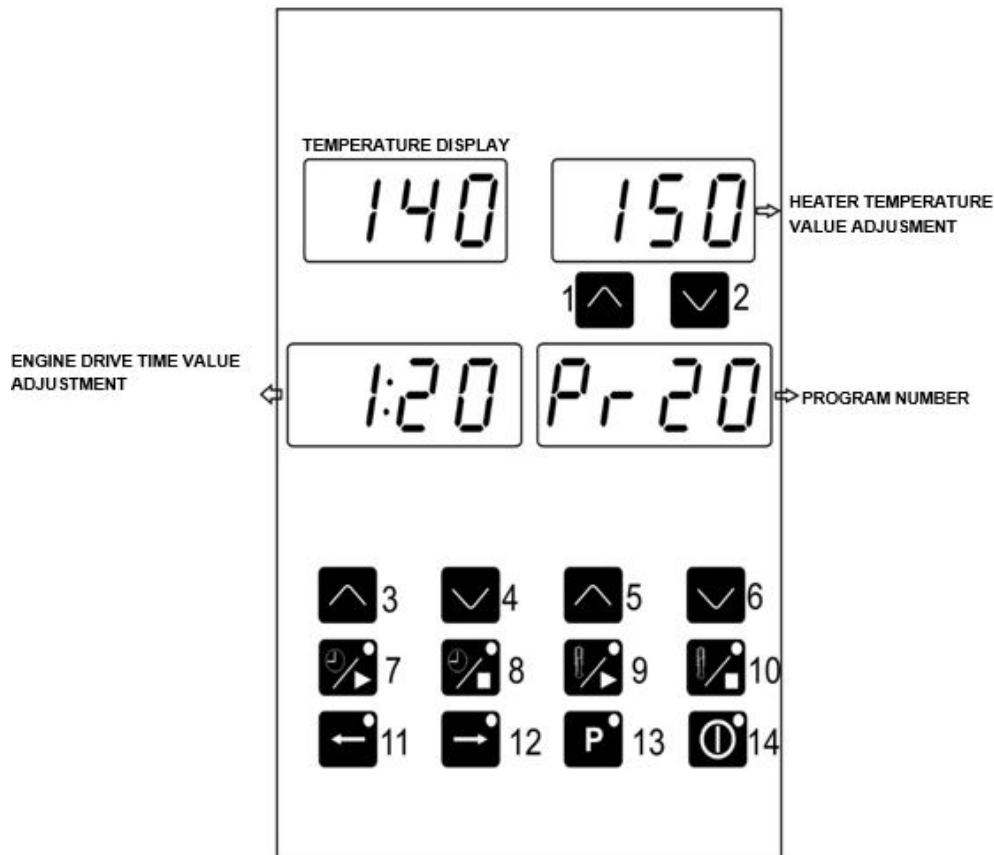

**1- 2. Temperature Set Increase and Decrease Buttons:** With these buttons, the temperature set valves of program number that appear on the upper display are changed.

**3- 4. Engine Driver Time Increase and Decrease Buttons:** Set the time in minutes and seconds with these buttons.

**5- 6. Program Increase and Decrease Buttons:** The desired program number is selected using these buttons.

**7. Engine Start Button:** Press this button to start the engine.

**8. Engine Stop Button:** Press this button to stop the engine.

**9. Heater Start Button:** Press this button to activate the heater output is active.

**10. Heater Stop Button:** This button stops the output when heater output is active.

**11. Belt Back Button:** Rotates the engine counterclockwise when this button is pressed.

**12. Belt Forded Button:** Rotates the engine clockwise when this button is pressed.

**13. Program Set Button:** Press this button once for 5 seconds and enter the set section.

**14. ON/OFF Button:** With this button the device is returned to the "on" or "off" state. Button turns off when the device is switched off screen turns off.

## Changing Program Values and Record

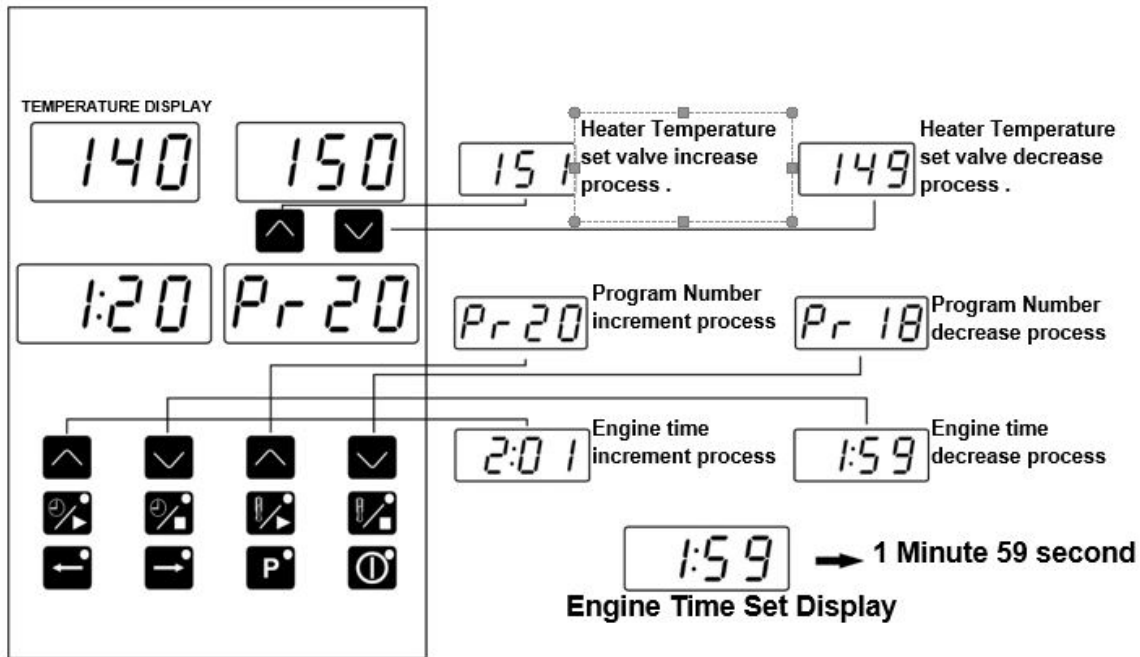

The values of that program appear on the screens after the program number has been entered. Set values are changed with the help of boost and decrease buttons. Press 'P' button for 5 seconds to enter the set section. In this case the changed set values are recorded. The set values that are modified are instantaneous values. These values are not saved to the program. The old values of the program are displayed again when switching to the off position or when the power is turned off.

Programs are only saved when the heater is in the stop position. The set values changed in the start position are instantaneous values. These values are not saved to the program. The old values of the program are displayed again when switching to the stop position.

### 4.1 Warnings:

1. If the product does not cook, check the cooking times and temperature setting conveyor can be spinning fast.
2. If the product is over cooked, check the cooking times and temperature settings can be turning slowly.
3. If all values are normal but the product still does not cook or over heat, call the manufacturer.
4. This issue is fixed by pressing the ON/OFF  button on the display when the burner in the gas ovens gives a fault alarm. The more detailed description is on page 57.
5. Do not keep combustible and explosive material around the machine.

### 4.2 Closing

To turn off the oven, touch ON/OFF  and switch off with 0-1 switch.

### 4.3 Fault / Warning Messages:

Our machines have a checked fault warnings message. An unexpected error in the operation of the oven that may occur will appear on the as it appears below.

**FAULT 1:** Lockout signal after no flame and all ignition trials are expired. This error condition is stopping the boiler and to get to normal operation again, manual/remote reset is required. By using the local reset key, number of resets are not limited. However, all remote resets (communication) are limited to 5 resets per hour.

**FAULT 2:** False flame indication – error is created if flame signal is measured with no heat demand currently present. This error condition also requires manual reset action.

**FAULT 3:** High Limit error – if the safety cut off switch opens due to an overheat situation in the application. High Limit error will be generated.

**FAULT 5:** APS Error – if the APS does not close within the specified time (10 sec) when the combustion Fan is switched on, error will be generated.

**FAULT 8:** Flame circuit error- during normal operation of the ignition controller, flame circuit is regularly checked. This check has predictable behavior and several steps. If check fails, error will be set.

**FAULT 9:** Gas valve drive circuit error – during normal operation of the ignition controller, valve drive circuit is regularly checked. This check has predictable behavior and several steps. If check fails, error will be set.

**FAULT 13:** All remote resets (communication) – the number limited to 5 of remote resets in an hour is more than allowed. Volatile lockout error is set; the error disappears after power off/on the boiler.

**FAULT 21:** ADC error- internal controller error.

**FAULT 25:** CRC error – matching error on CRC codes (different software versions).

**FAULT 23:** At burner start up inputs do not match after the specified wait APS open time (10 sec).

**FAULT 26:** Reset Knob error – if the button is switched on for more than 10 seconds. Error is set till the Reset Knob will be released.

### 4.4 Burner Fault:

Occurs when the burner does not fire or if there is fault in the burner system.

## 4.5 Functions:

### 4.5.1 Temperature Cutting Switch:

Our oven has a temperature cut. Off switch for your safety and protection. This switch is specially designed to prevent the oven from overheating and causing damage in a small possibility, if the operating temperature of the furnace increases and the power is prevented from being transferred to the furnace. No parts are damaged due to excessive temperature.



**WARNING!** Do not use an external switch to do not block to the temperature switch.

### 4.5.2 Electrical Installations:



**WARNING!** Grounding must be done properly before install of the oven. Electrical damage causes fatal injuries or death.

#### For All Foreign Countries:

Apply local electrical rules.

1. All Poles connect switches have 3mm wide.
2. Grounding cable head is back on the oven.
3. If you use more than one oven (double or triple) each oven must have its own switch and all switches should be close together.

### 4.5.3 Limitation Requirements – Gas Ovens:

1. This installation shall be carried out by a fast-connecting device in accordance with the standards for fasteners for gas-operated devices with a gas connector in accordance with the fastener standards for movable gas appliances.
2. The installation of the restriction should limit the movement of the oven, regardless of the connection element. The quick disconnect tool or its pipe should limit the movement of the oven.
3. If the restriction is removed due to cleaning or maintenance, it must be returned back to the original after cleaning or maintenance has finished.

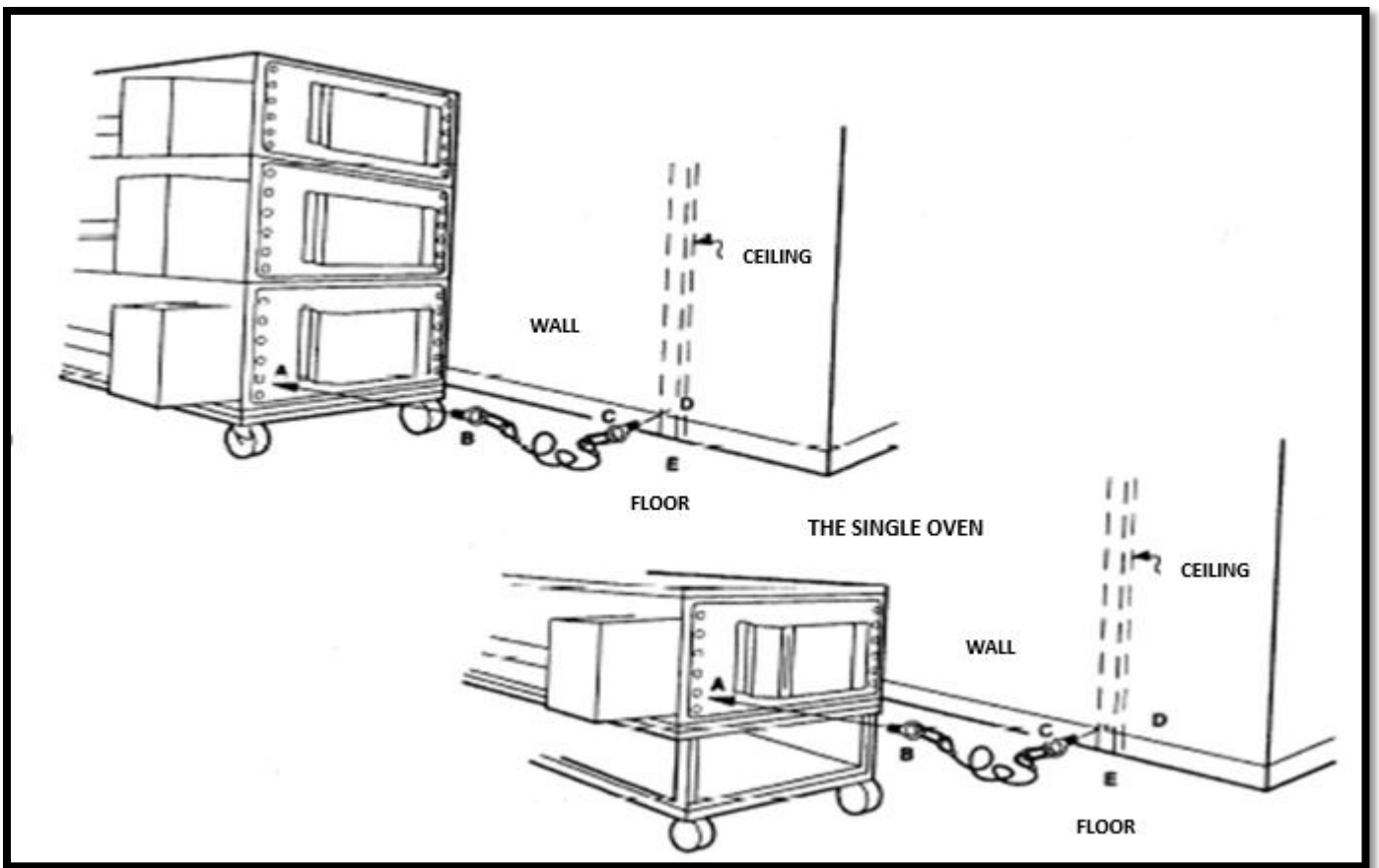

1. Connect the "B" part and its cable to "A" part with bolt.
2. Connect the "C" part and its cable to support of the wall "D" or "E" with bolt.

**NOTE:** Connection points are the same with double or triple oven assembly.

#### 4.5.4 Operator Maintenance:



**WARNING!** Disconnect power supply before servicing or cleaning this oven. Safeguard power so it cannot be accidentally restored. Failure to do so could result in dismemberment, electrocution, or fatal injury. There is more than one power supply connection point when ovens are stacked. Make sure that all switches are in the "OFF" position before cleaning or maintenance.

To maintain maximum efficiency of the oven, it is necessary to keep it clean, all ventilation louvers on the oven must be cleaned regularly. Oven use and type of product will actually determine the frequency of cleaning. The conveyor drive chain should be checked during the weekly cleaning cycle to see if it has become loose. Loose chain operation will **DAMAGE** the conveyor drive motor.

If the oven fails to operate, check the circuit breaker to be sure it is turned on. Be sure that circuit breaker is ok before you call the Authorized Service Agency. The name and phone number of the Authorized Service Agency should be located at the bottom of the data plate

#### 4.5.5 Cleaning Instructions:

The oven contains electrical components. Before cleaning the oven, switch off and disconnect the oven from the electrical supply.

No electrical components should be subjected to moisture. It is, therefore, important that the oven is wiped down carefully. NEVER throw buckets of water over the oven or subject it to pressure washing from a hose or a pressure spray. If water or other liquid is spilled on the oven, make sure that none has entered the control box area before switching on. If in doubt, call your service company.



**WARNING!** Oven must be cool. Do not use power-cleaning equipment, steel wool, or wire brushes on stainless steel surfaces.

#### DAILY;

1. Clean the outer surfaces with a mild detergent cloth. You can also use a commercial stainless steel cleaner product. Then clean the detergent residue with a wet cloth.
2. Wash the preservatives of the front and rear waste collection plates with a mild detergent and rinse with water.
3. Wash the outlet sheet with a mild detergent and rinse with water.
4. Wash the stoppers with a mild detergent and rinse with water.
5. Clean the loose particles inside, then wipe them with a mild detergent, and clean the detergent residue with a wet cloth.
6. Clean the conveyor with a clean cloth or with a soft wire brush.

On exterior of oven, deposits of baked-on splatter, oil, grease, or light discoloration may be removed with any of several commercial cleaners. Consult with your local supplier.

#### MONTHLY;

1. Remove, disassemble and clean air vents. Refer to "Air Duct Removal" for more information.
2. Remove the tape, dismantle and clean it. See "tape mounting and wire mounting" for more information.
3. Remove, disassemble and clean the oven room front and rear covers.

**NOTE:** Be sure to clean and inspect the ventilation hood in accordance with the ventilation hood manufacturer's specifications.

#### 4.5.6 Protective Maintenance:

Although this oven has been designed to be as trouble free as possible, periodic Preventive Maintenance is essential to maintain peak performance. It is necessary to keep the motors, fans, and electronic controls free of dirt, dust and debris to insure proper cooling. Overheating is detrimental to the life of all components mentioned.

The periodic intervals for preventative cleaning may vary greatly depending upon the environment in which the oven is operating.

You must discuss the need for Preventive Maintenance with your Authorized Service Company to establish a proper program.

## SECTION 5: COOKED PRODUCTS

### 5.1 Some of The Cooked Products:

- Brownie
- Hamburger
- Hot Dogs
- Omelet
- Pancakes
- Mixed Vegetable Plate
- Steakhouse
- Skewers
- Meatball
- Potato
- Borek
- Chicken Wings
- Grilled Chicken
- Chicken Saute
- Bread
- Breakfast
- Fish
- Seafood
- Pizza
- Lavas
- Lahmacun
- Pita
- Kunefe
- Chocolate Cookie
- Pie
- Etc. Many Foods

SEN series ovens, show much better performance than other ovens (Especially pizza cooking).

### 5.2 Cooking Time and Temperature:

#### PIZZA

- ALUMINIUM PAN - FRESH	- TIME: 6 MINUTES	- 260 °C
----------------------------	-------------------	----------

#### PİDE

- OVER CONVEYOR - FRESH	- TIME: 5 MINUTES	- 260 °C
----------------------------	-------------------	----------

### 5.3 Total Cooking Calculation:

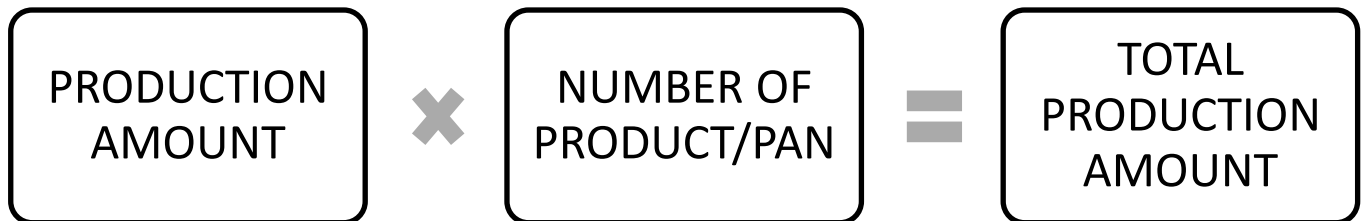

#### Sample 1:

Oven Chamber Length: 710 mm.  
 Cooking Time: 2 dk.  
 Pan Length: 250 mm.

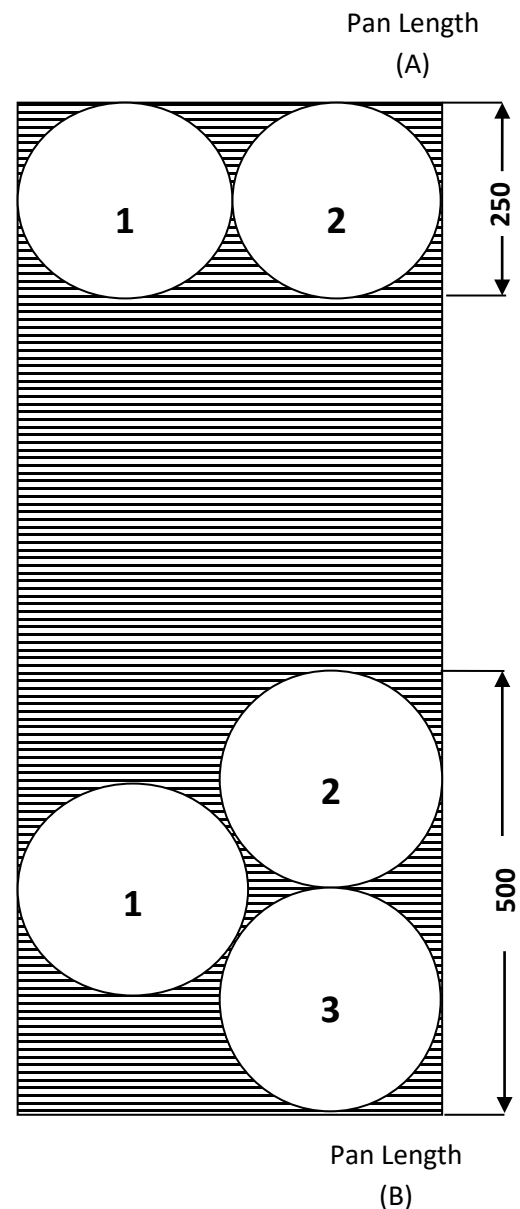
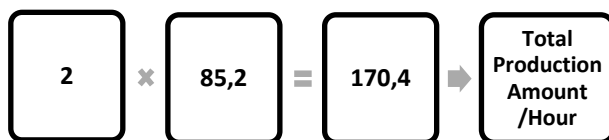

#### Sample 2:

Oven Chamber Length: 710 mm.  
 Cooking Time: 5 dk.  
 Pan Length: 500 mm.

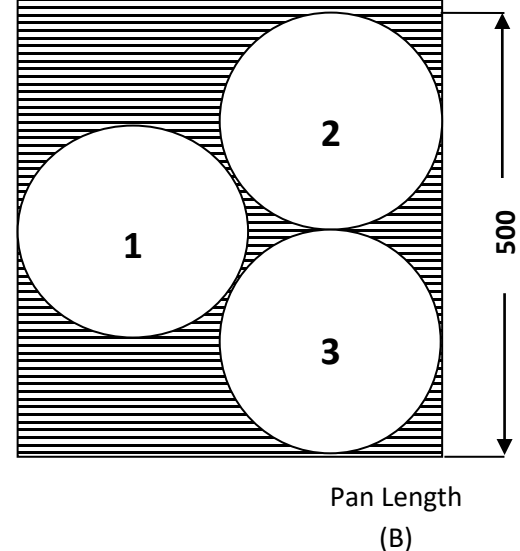
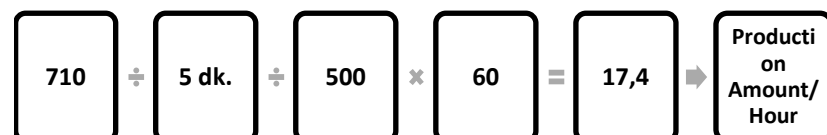

#### 5.4 Sample Capacity Table:

SAMPLE CAPACITY TABLE				
Pizza Diameter	3 Minutes	3 ½	4 Minutes	4 ½
30 cm	55	47	41	37
36 cm	40	34	30	27
41 cm	35	30	26	23
Pizza Diameter	5 Minutes	5 ½	6 Minutes	6 ½
30 cm	33	30	28	25
36 cm	24	22	20	18
41 cm	21	19	18	16
Pizza Diameter	7 Minutes	7 ½	8 Minutes	
30 cm	24	22	21	
36 cm	17	16	15	
41 cm	15	14	13	

# SPARE PARTS MANUAL

# M00375 FRONT

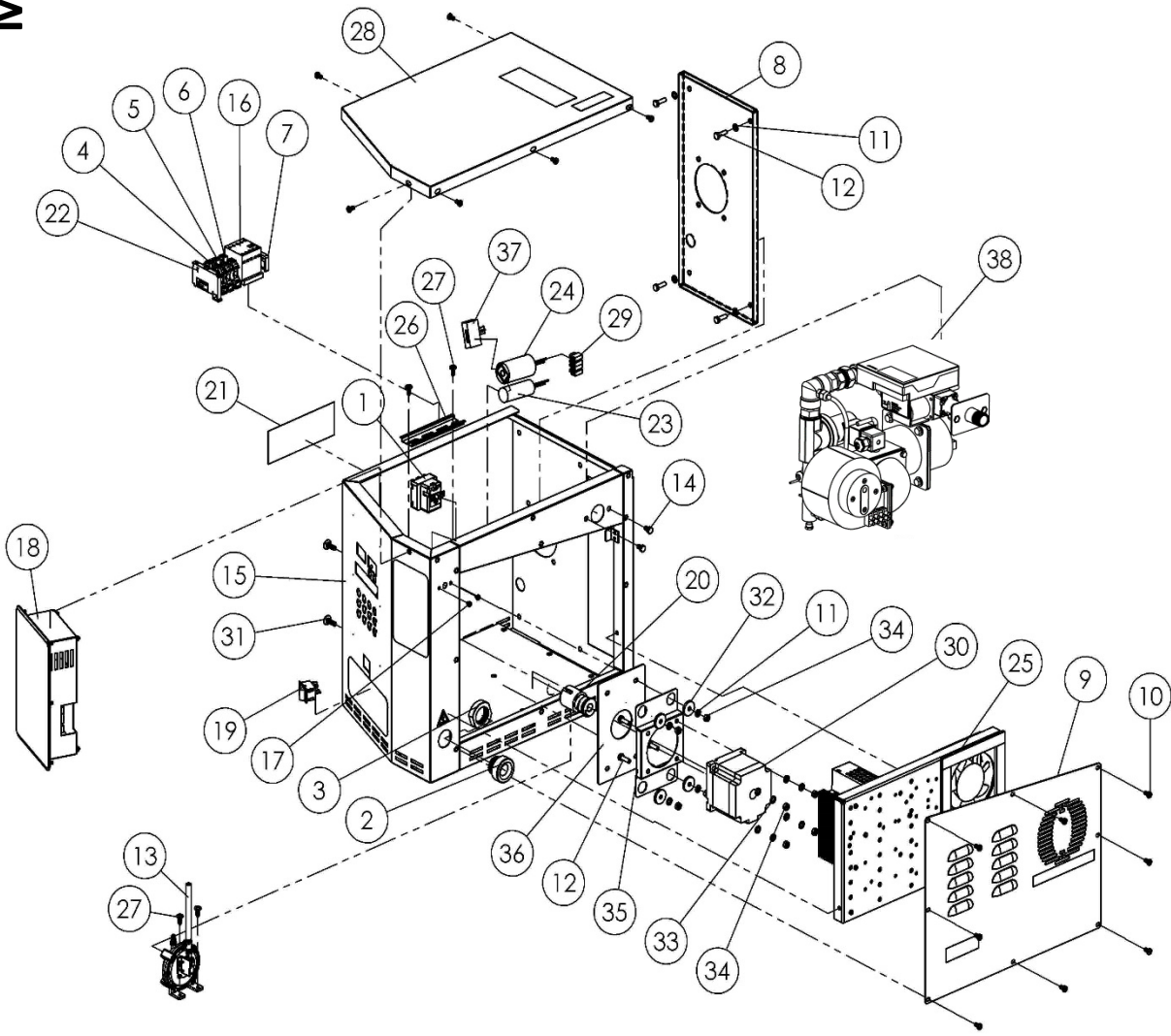

### M00375 (FRONT) SPARE PARTS LIST

ITEM	SPARE PARTS NUMBER	SPARE PARTS DESCRIPTION	UNIT
1	01815	LIMIT THERMOSTAT	1
2	01184	RECORD	1
3	01089	RECORD NUT	1
4	02209	TERMINALS(GROUND)	1
5	02210	TERMINALS	1
6	02211	TERMINALS	1
7	00292	LIMITER	1
8	01625	SUPPORT SHEET	1
9	01510M	COVER SHEET	1
10	00046	BOLT	15
11	00042	WASHER	13
12	00041	BOLT	9
13	01103M	AIR PROTESTAT	1
14	02580	BOLT	2
15	00365M	CONTROLLER BOX	1
16	01879	CONTACTOR	1
17	01831	BOLT	2
18	00364M	SCREEN	1
19	08091	BUTTON	1

ITEM	SPARE PARTS NUMBER	SPARE PARTS DESCRIPTION	UNIT
20	01515M	ENGINE MOUTING ROD	1
21	01878	LABEL	1
22	01865	GLASS BRAKER TERMINALS	1
23	01882	CONDENSER	1
24	02194	CONDENSER	1
25	M00369	SSR BOX	1
26	01886	TERMINAL RAIL	1
27	02178	BOLT	4
28	01511M	CONTROLLER BOX COVER	1
29	00061	TERMINAL	2
30	01850	ENGINE	1
31	01867	BOLT	4
32	00006	WASHER	4
33	00317	WASHER	4
34	01305	NUT	8
35	01862	STEP ENGINE SHEET	1
36	01861	ENGINE SHEET	1
37	02351	BURNER COMMUNICATIONS CARD	1
38	M00390	BURNER	1

# M00321 FRONT COVER

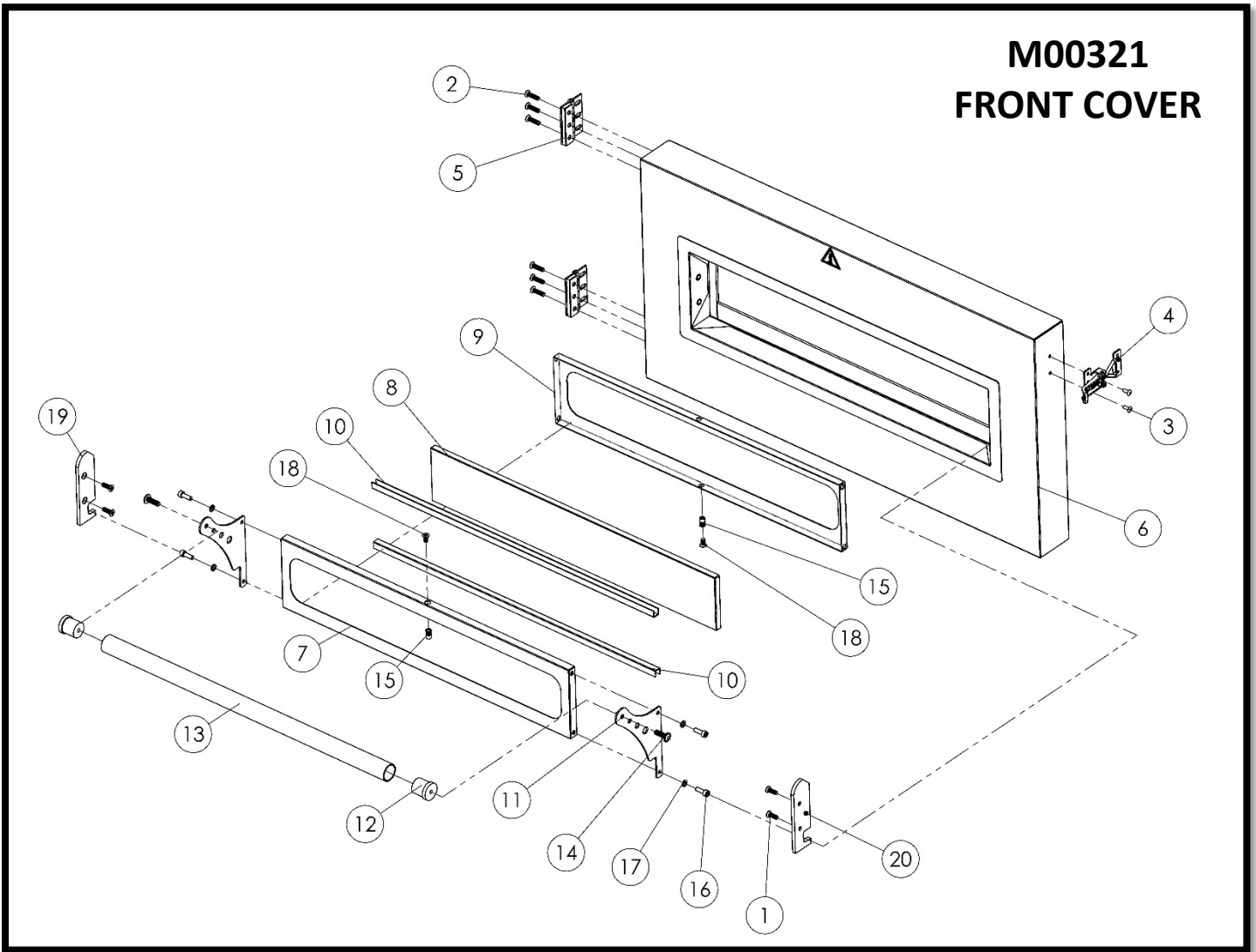

## M00321 (FRONT COVER) SPARE PARTS LIST

ITEM	SPARE PARTS NUMBER	SPARE PARTS DESCRIPTION	UNIT
1	01558	BOLT	4
2	01530	BOLT	6
3	01529	RIVET	2
4	01528	HOOD LOCK	1
5	01067M	HINGE	2
6	01068M	COVER	1
7	07161	GLASS FRAME	1
8	01548	WINDOW	1
9	07162	GLASS FRAME	1
10	07160	GLASS FRAME BRACKET	2
11	01759	GLASS EDGE SHEET	2
12	01752-1	RUBBER PLUG	2
13	01753-1	COVER HANDLE	1
14	02342	BOLT	2
15	00045	FIX	6
16	101503	BOLT	4
17	04077	WASHER	4
18	00157	BOLT	2
19	07172	GLASS ON/OFF LAMA	1
20	07170	GLASS ON/OFF LAMA	1

## M00403 BACK COVER (TYPE-1)

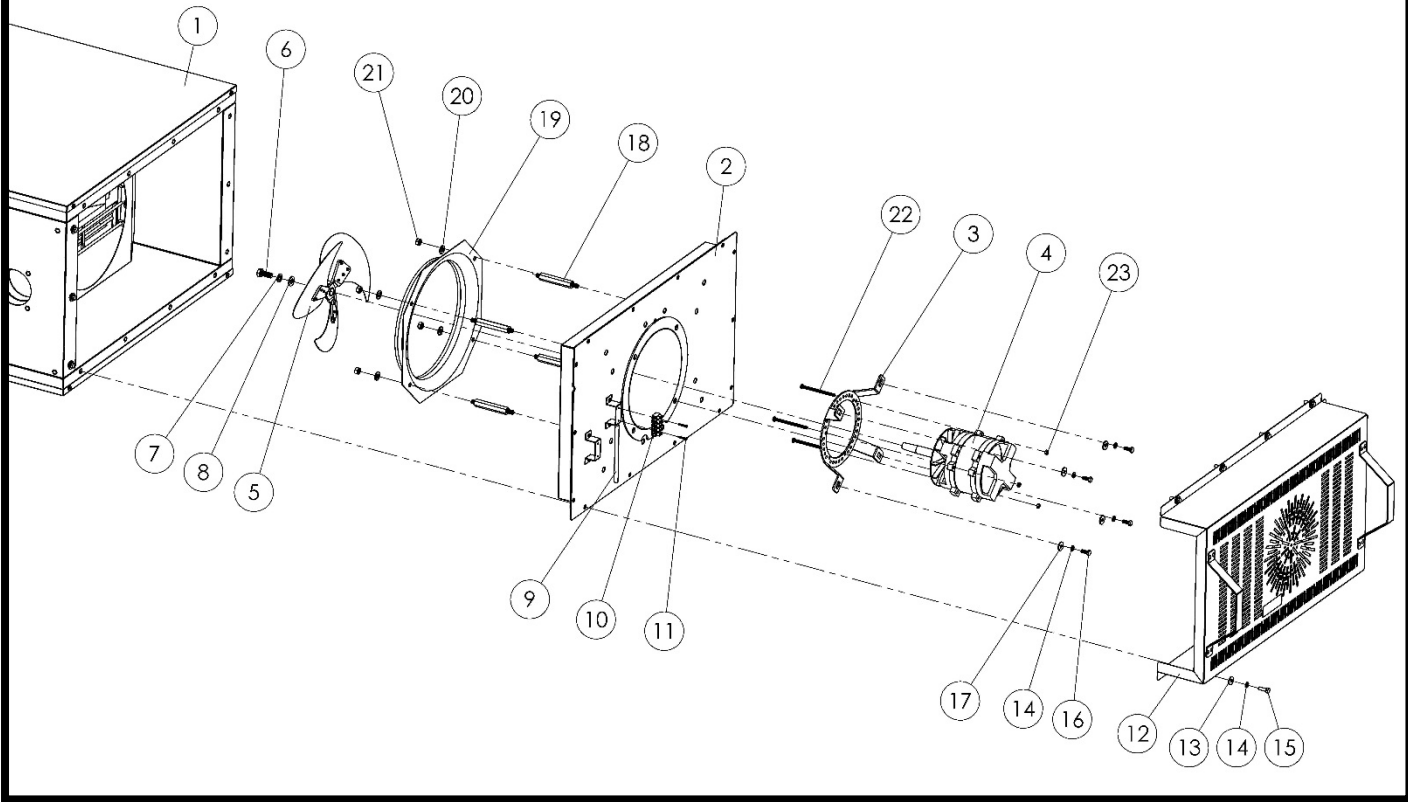

### M00403 BACK COVER (TYPE-1) SPARE PARTS LIST

ITEM	SPARE PARTS NUMBER	SPARE PARTS DESCRIPTION	UNIT
1	M00269	BODY	1
2	01100M	BACK ISOLATION PACKAGE	1
3	01984	ENGINE SHEET	1
4	101509	F.I.R ENGINE	1
5	01078M	FAN	1
6	00279	BOLT	1
7	01960	WASHER	1
8	00277	WASHER	1
9	01317	RESISTANCE OUTPUT MACARON	1
10	01728	TERMINAL	1
11	01672	BOLT	2
12	01075M	BACK COVER	1
13	01299	WASHER	14
14	00042	WASHER	18
15	00041	BOLT	14
16	04082	BOLT	4
17	02579	WASHER	4
18	01717	STUD	4
19	01718	FAN CASING SHEET	1
20	01961	WASHER	4
21	01959	NUT	4
22	02391	BOLT	3
23	00052	NUT	3

## M00402 BACK COVER (TYPE-2)

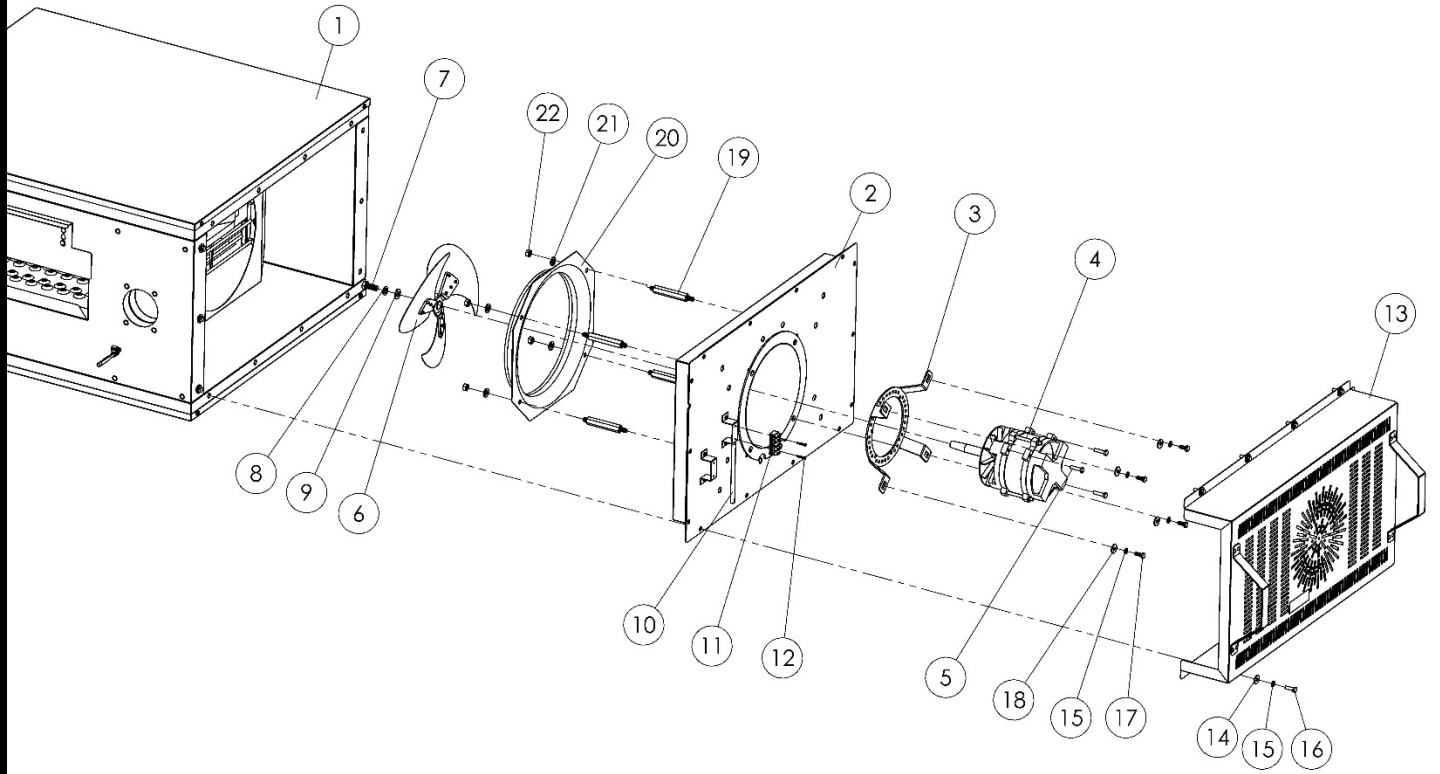

### M00402 BACK COVER (TYPE-2) SPARE PARTS LIST

ITEM	SPARE PARTS NUMBER	SPARE PARTS DESCRIPTION	UNIT
1	M00269	BODY	1
2	01100M	BACK ISOLATION PACKAGE	1
3	01672	BOLT	2
4	01728	TERMINAL	1
5	01317	RESISTANCE OUTPUT MACARON	1
6	01717	STUD	4
7	01959	NUT	4
8	01961	WASHER	4
9	01718	FAN CASING SHEET	1
10	01722	WEDGE	4
11	01719	BAHÇIVAN ENGINE	1
12	02579	WASHER	4
13	00042	WASHER	18
14	01519	BOLT	4
15	00426M	FAN	1
16	01075M	BACK COVER	1
17	01299	WASHER	14
18	00041	BOLT	14

## M00269 BODY

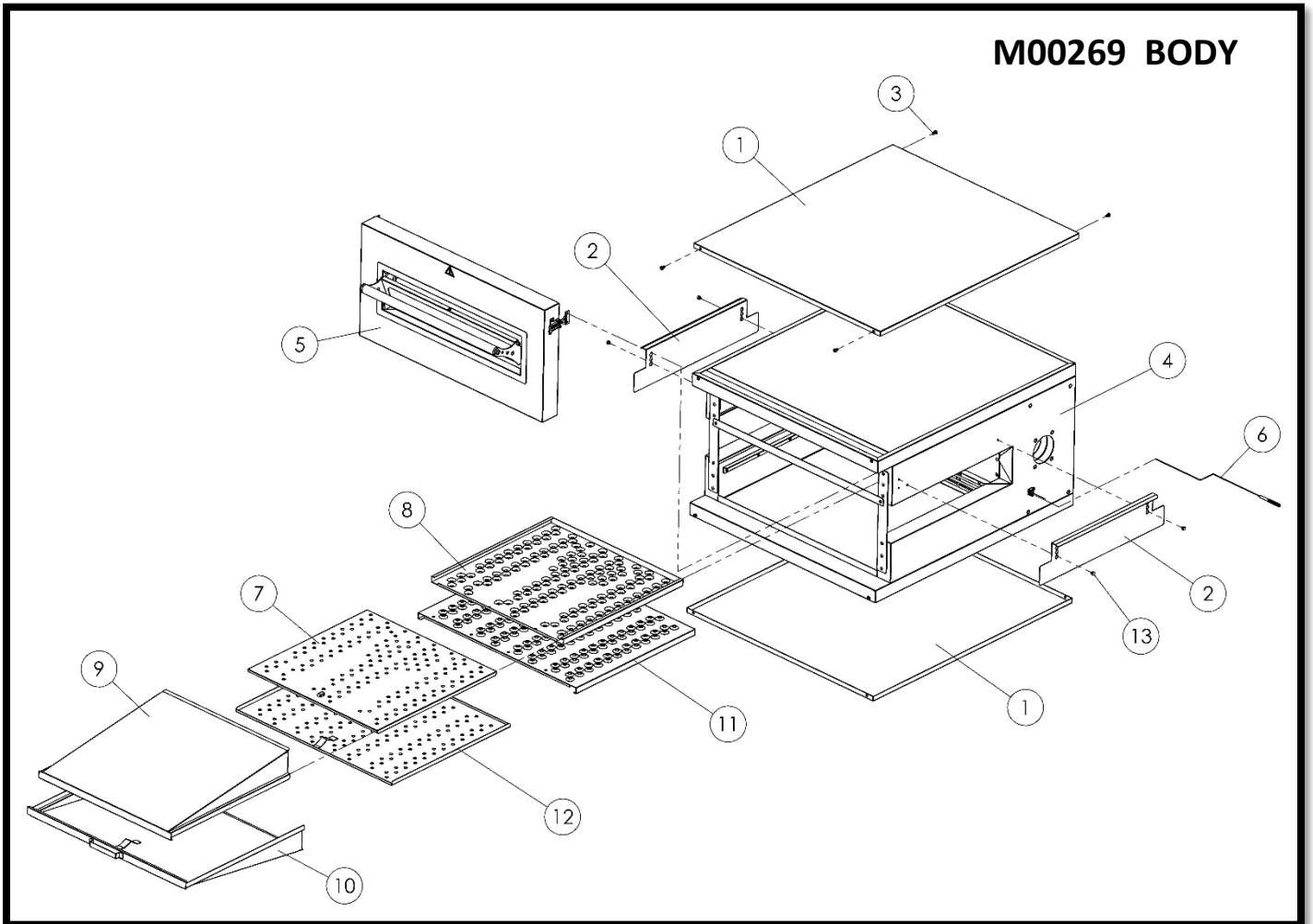

### M00269 (BODY) SPARE PARTS LIST

ITEM	SPARE PARTS NUMBER	SPARE PARTS DESCRIPTION	UNIT
1	01562	ISOLATION PACKAGE	2
2	01572-1	INPUT/OUTPUT SHEET	2
3	00046	BOLT	8
4	01081M	OVEN BODY	1
5	M00321	FRONT COVER	1
6	01731	THERMOCOUPLES	1
7	01070M	AIR DISTRIBUTOR SHEET	1
8	01630	SMALL FINGER PLASTER SHEET	1
9	01073M	SMALL AIRWAYS SHEET	1
10	01072M	BIG AIRWAYS SHEET	1
11	01631	BIG FINGER PLASTER SHEET	1
12	01071M	AIR MOUNTING SHEET	1
13	01596-1	PIN	4

M00369 SSR BOX

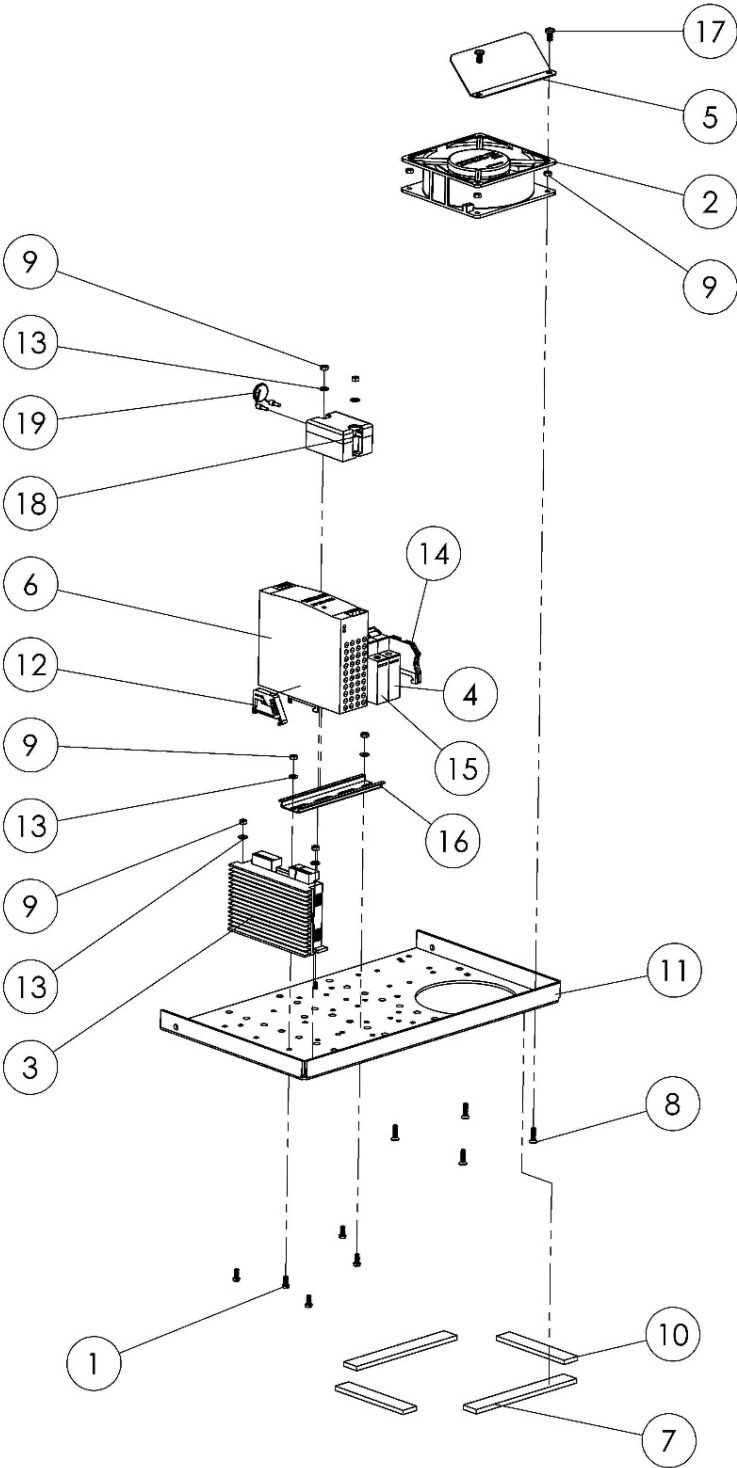

## M00369 (SSR BOX) SPARE PARTS LIST

ITEM NO.	SPARE PARTS NUMBER	SPARE PARTS DESCRIPTION	UNIT
1	01295	BOLT	7
2	01290	FAN	1
3	02320	SPEED CONTROL	1
4	00301	FUSE	1
5	02334	AIR ROUTING SHEET	1
6	02319	POWER SUPPLY	1
7	01307	SPONGE	2
8	01271	BOLT	4
9	02634	NUT	11
10	01306	SPONGE	2
11	01011	SSR SHEET	1
12	00292	LIMITER	1
13	01296	WASHER	7
14	00293	TERMINALS (GROUNDING)	1
15	02208	FUSE	1
16	01886	TERMINALS RAIL	1
17	00046	BOLT	2
18	01822	SSR RELAY	1
19	01292	VARISTOR	1

## M00271 BELT

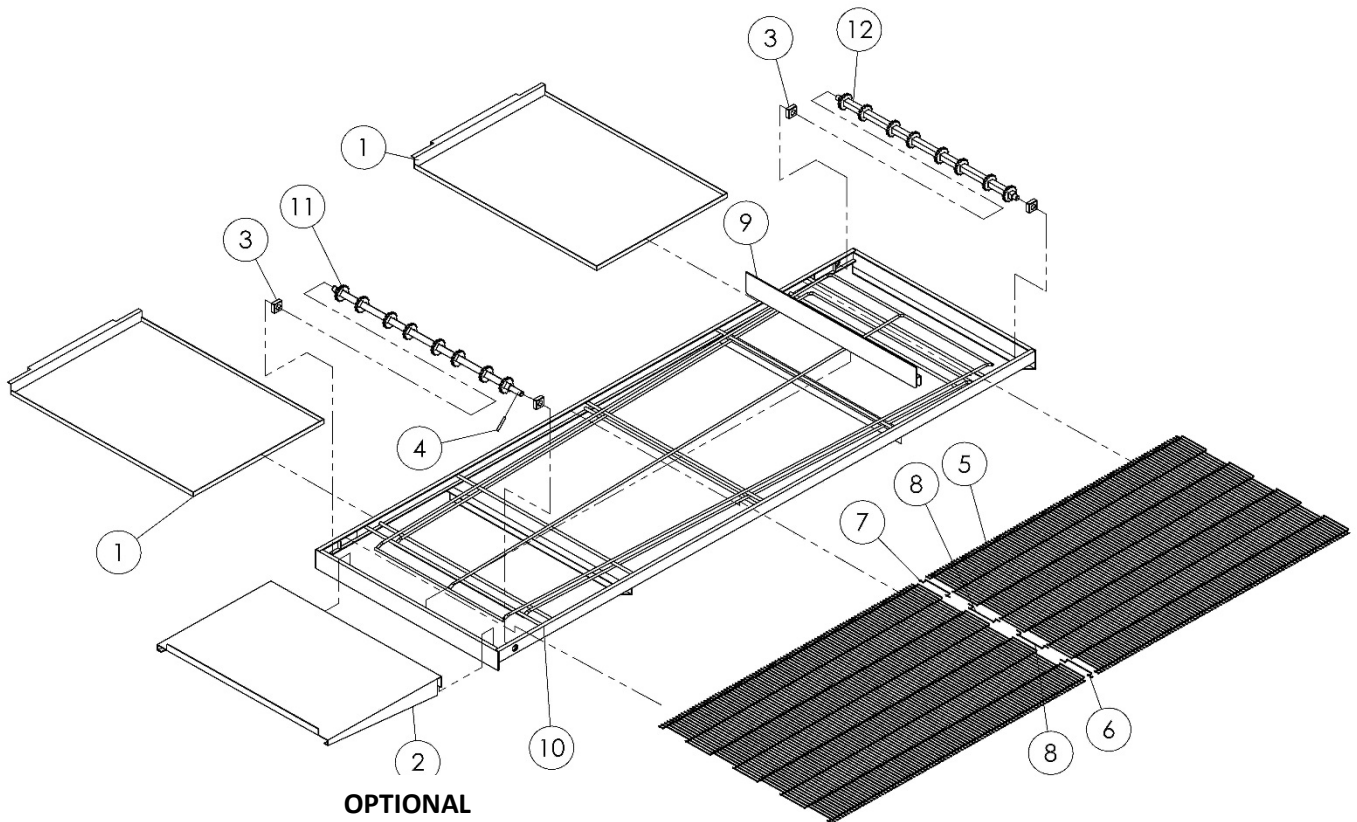

### M00271 (BELT) SPARE PARTS LIST

ITEM NO:	SPARE PARTS NUMBER	SPARE PARTS DESCRIPTION	UNIT
1	01504	WASTE PAN	2
2	01520	PRODUCT OUT SHEET (OPTIONAL)	1
3	01516	CONVEYOR DRIVE BEARING	4
4	00096	PIN	1
5	01739M	BELT	1
6	01736	BELT RIGHT LOCK WIRE	1
7	01737	BELT LEFT LOCK WIRE	1
8	01738	BELT LOCK MIDDLE WIRE	2
9	01505	LIMITER CHASIS	1
10	00325M	BELT CHASIS	1
11	00323M	CONVEYOR DRIVE SHAFT	1
12	00324M	CONVEYOR IDLE SHAFT	1

# M00390 BURNER

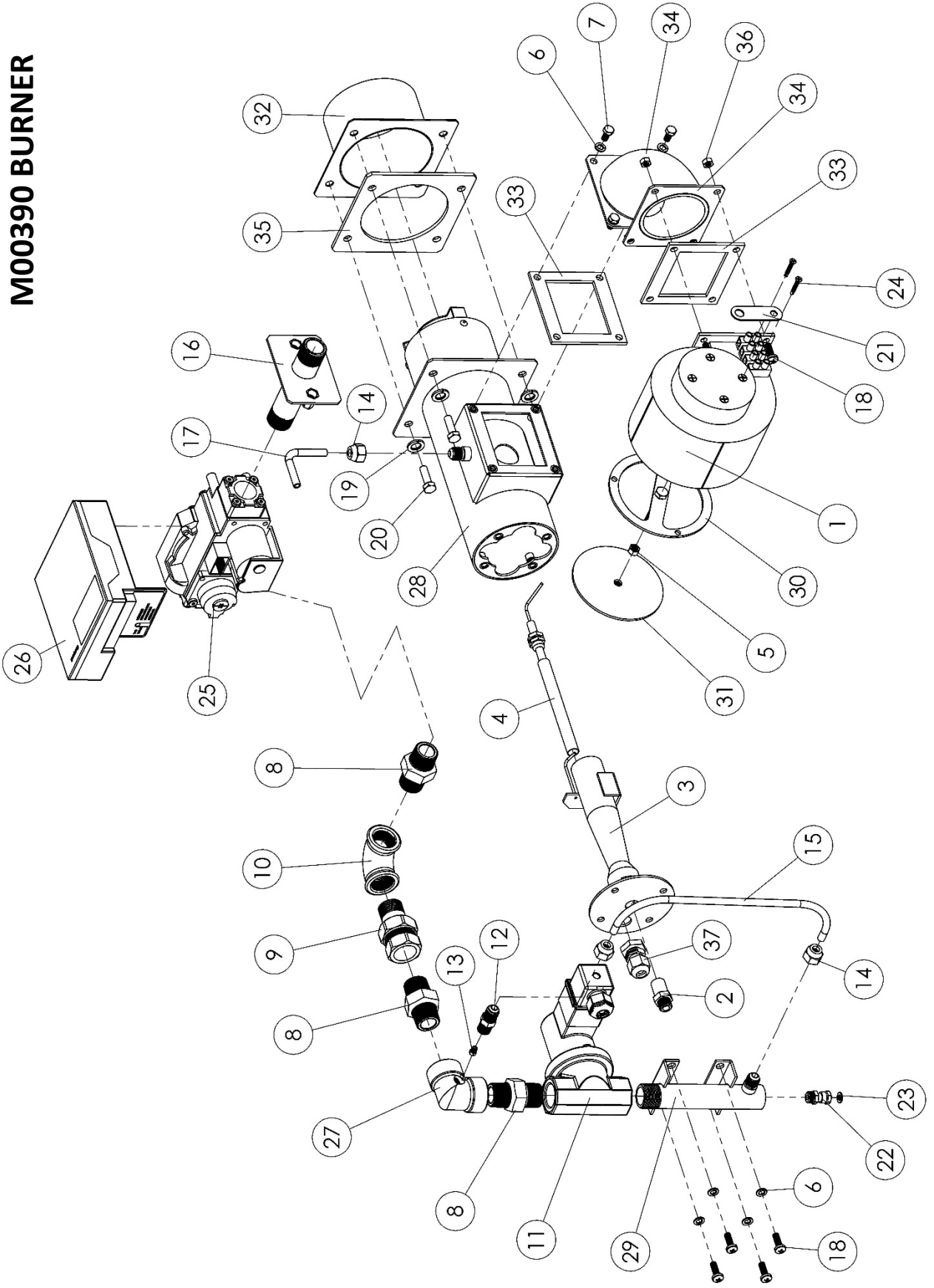

### M00390 (BURNER) SPARE PARTS LIST

ITEM NO.	SPARE PARTS NUMBER	SPARE PARTS DESCRIPTION	UNIT
1	01666	ENGINE (BURNER)	1
2	01668	NOZZLE	1
3	01517M	BURNER CORE	1
4	01518M	IGNITION ELECTRODE	1
5	02581	NUT	1
6	01685	WASHER	8
7	00048	BOLT	4
8	02640	NIPPLE	3
9	02639	RECORD	1
10	02649	ELBOW	1
11	01686	GAS VALVE	1
12	01689	NIPPLE	1
13	01690	NOZZLE	1
14	02541	NUT	3
15	01688	PIPE	1
16	01516M	GAS ENTRANCE PIPE	1
17	01699	AIR PROCESS PIPE	1
18	01695	BOLT	4
19	00042	WASHER	4
20	00041	BOLT	4
21	01698	ENGINE CONDENSER SHEET	1
22	01671	TEST NIPPLE	1
23	01670	WASHER	1
24	01672	BOLT	2
25	01881	VALVE	1
26	01880	BRAIN	1
27	01885	ELBOW	1
28	01501M	BURNER BODY	1
29	01502M	BURNER NOZZLE ELBOW	1
30	01505M	AIR ADJUSTMENT CHASSIS	1
31	01506M	AIR ADJUSTMENT COVER	1
32	01507M	BURNER INLET PIPE	1
33	101504	CYLINDER HEAD GASKET	2
34	00395M	ELBOW	1
35	101505	CYLINDER HEAD GASKET	1
36	00052	NUT	4
37	07139	RECORD	1



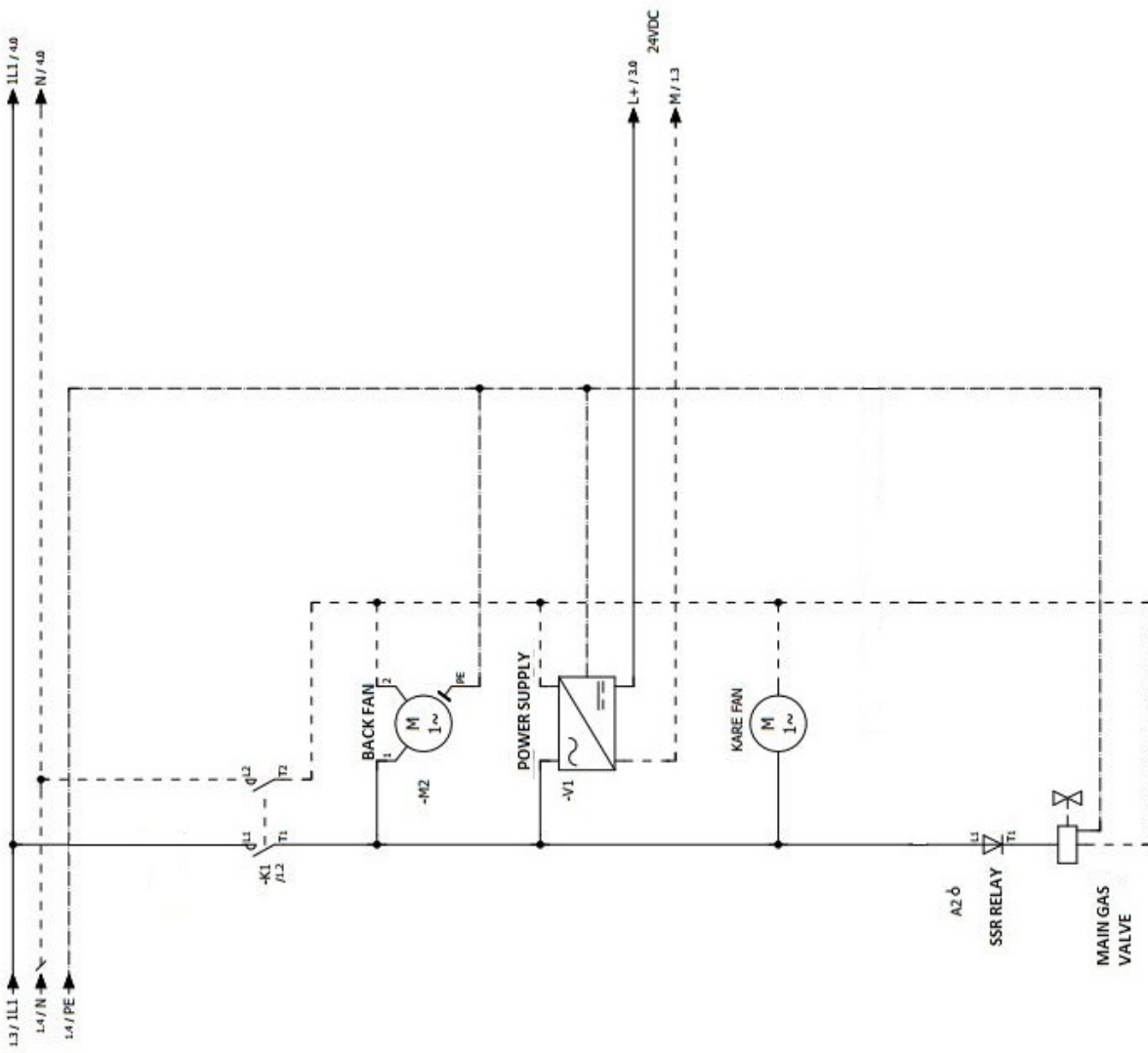

Date		05.06.2018	Date		1502 Rev.01	ELEKTRIK - ELEKTRONIK DEVRE SEMASI		+ 1502 Rev.01	
Ed.			Ed.					Page	
Name		SENGÜN MAKİNA	Name					Total Page	
Original			Original					4	

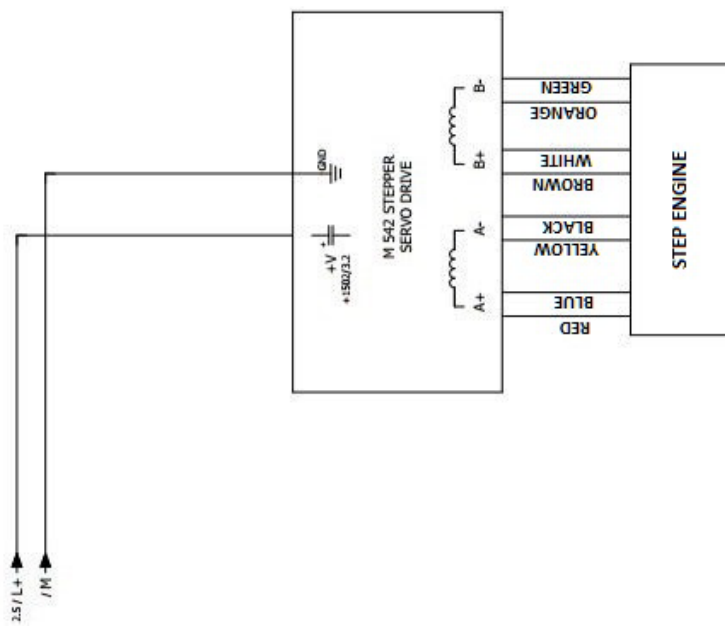

Modification	Date	Name	Original
	04.05.2018		
	Est.		
	Appr.		



## SECTION 8: PROBLEM SOLUING

### 8.1 Products Are Not Cooking:

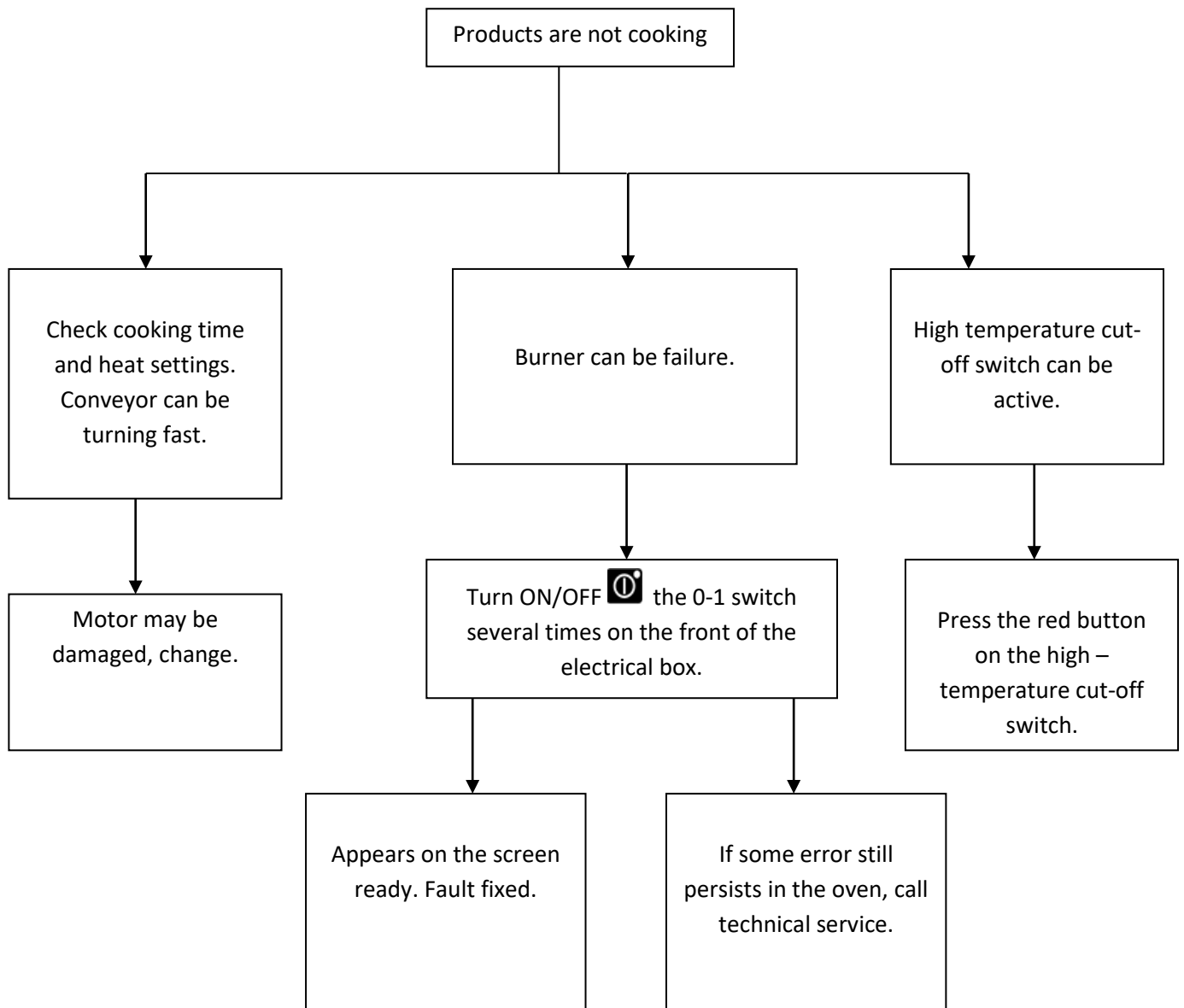

### 8.2 How to Call Technical Service?

If the oven not working, see if automatic fuse works. If there is no problem, call technical service. There is technical service number on the information plate on the back of the oven. If you can't see technical service number on the oven, please call company.

## SECTION 9: LABELS



(High Temperature)

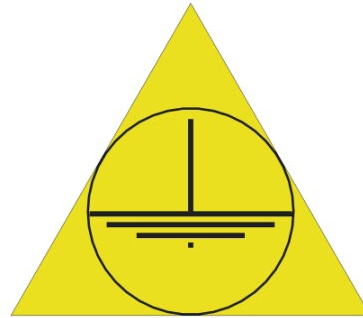



(Grounding)



Electrical Input



Warning Labels

	VOLT /Voltage/FAZ/Stage	230V/50/60 Hz/1N	ÜRÜN ADI/Product Name: TR
	GAZ BASINCI/ Gas Pressure	G21-21 mbar	ÜFLEMELİ KONVEYÖRLÜ FIRIN/BLOWING CONVEYOR OVEN
<b>ŞENGÜN MAKİNA İNŞ. ve KIRT. SAN. TİC. LTD.ŞTİ.</b> İ.O.S.B. Mah. Atatürk Bulvarı Pufa İş Merkezi No:98 Bodrum Kat: 2/3 Başakşehir / İSTANBUL Tel: +90 (212) 671 23 23 (pbx) Fax: +90 (212) 671 88 28 www.sengunmakina.com   info@sengunmakina.com	SERİ NO / serial number		KATEGORİ/Category
	GÜÇ / Power	NG 13 kW	İ2H,İ2E
 1984	AKIM / Nominal Current	2 Amper	ÜRETİM YILI/ Production Year
	ÖLÇÜ / Dimension	1043x1710x450mm	2018
MADE IN TURKEY	AĞIRLIK/ Weight	145 kg	MODEL / Model
PIN CN0161			SEN 1502
			Montaj Tipi installation Codes
			A1
			IP
			21

Technical Label (Product Card)

**CAUTION !**

DO NOT PUT ANY HOT MATERIAL ON THIS AREA !!!

(NEWFANGLED PRODUCT FROM THE OVEN, POT, PAN, SALVER, ETC..)

**CAUTION !**

⇒ MORE THAN ONE POWER SUPPLY DISCONNECT ALL POWER BEFORE SERVICING.

⇒ DO NOT INSTALL CLOSER THAN 33 INCHES FROM THIS WALL.

**FOR EMERGENCY ONLY**

⇒ TURN THE MAIN SWITCH BELOW THE OPERATOR PANEL ( PRESS "0" ) OFF IN ORDER TO STOP THE OVEN.

Warning Labels





**ŞENGÜN MAKİNA İNŞAAT ve KIRTASIYE SAN. TİC. LTD. ŞTİ.**

İkitelli Organized Industrial Area, Atatürk Boulevard, Pufa Business Center, No: 98 Basement Floor: 2-3  
Başakşehir/ İstanbul | Türkiye

Phone : +90 212 671 23 23 (Pbx)

Phone 2 : +90 212 671 84 24

Fax : +90 212 671 88 28

GSM : +90 533 957 14 53

E-Mail : [info@sengunmakina.com](mailto:info@sengunmakina.com)

[www.sengunmakina.com](http://www.sengunmakina.com) – [www.acpisir.com](http://www.acpisir.com)