

SENOVEN[®]

MODEL SEN 3000 AUTOMATIC BROILER

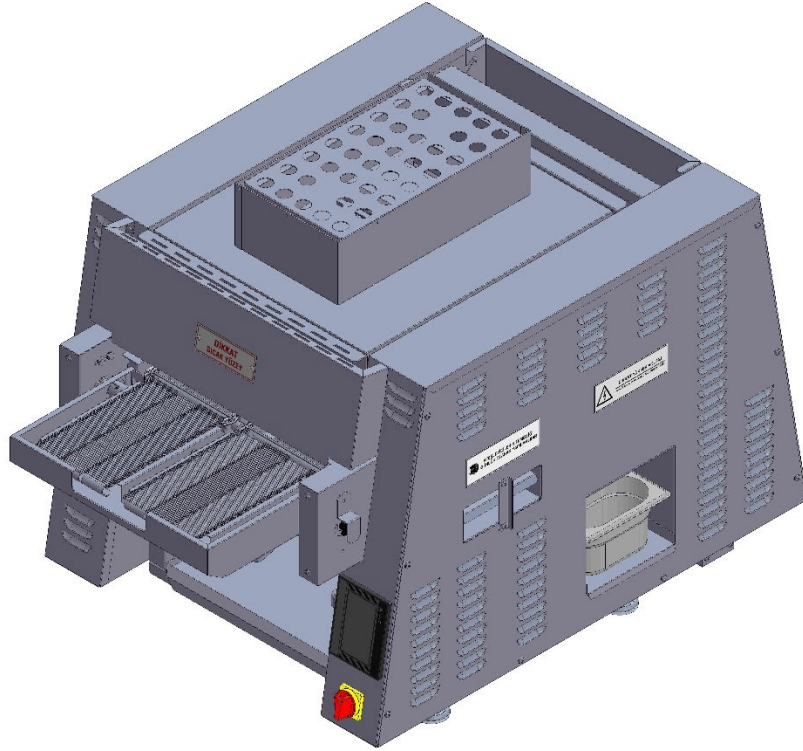

INSTRUCTIONS FOR USE AND MAINTENANCE

ŞENGÜN MAKİNA İNŞAAT ve KIRTASIYE SAN. TİC. LTD. ŞTİ

These instructions are valid only if the country code appears on the device. If country code does not feature on the device, please resort to technical requirements comprising necessary instructions for the adjustment of device to the current requirements in the country.

This device should be installed according to the applicable regulations and should only be used in a well-ventilated environment. Before installing and using the device, please refer to the instructions.

CERTIFICATE OF WARRANTY



BATCH NO :

DATE OF SALE:

SEN – 3000 AUTOMATIC BROILER and AUXILLIARY EQUIPMENT, which has been sold on the date specified above is put under guarantee for a period of 1 YEAR against all kinds of manufacturing defects by its manufacturer **ŞENGÜN MAKİNA İNŞAAT ve KIRTASIYE SAN. TİC. LTD. ŞTİ.**

Warranty Terms;

- Warranty terms start after the product delivery for 1 year.
- Recommended daily working time is 10 hours. The scope of warranty is assessed by year or by working hours.
- Documents are invalid, if haven't sale date and confirm signature of company. You have to show the warranty certificate to benefit from the warranty.
- Device is guaranteed against defects if mount and use as described in the use and maintenance manual.
- Detection the location of defects, and elimination of the problems are responsibilities of the **ŞENGÜN MAKİNA...**
- Warranty terms include only one device. You can't claim any rights or compensation for another devices.
- If Changes are made at the type, model and serial numbers, the warranty eliminates.
- If material, worker or assembly defects appear, repaired free by **ŞENGÜN MAKİNA** at the product warranty period (Transportation cost is not included).
- Failures are only repaired by **ŞENGÜN MAKİNA's** personal. The intervention of unauthorized person cancels the appliance of warranty.
- Installation have to be done by **ŞENGÜN MAKİNA's** personal. If usage place changes, customer must give information to **ŞENGÜN MAKİNA**
- In the event of failure service must be informed.
- The failures and damages given by external factors are out of the warranty terms.
- Any failure of the product warranty period is added to the product warranty time. The repair time is until 20 working days.
- Istanbul courts are competent in case of dispute.

AUTHORIZED PERSON

STAMP –SIGNATURE

PRESENTATION

Dear User,

Thank you for your trust in our company and for preferring our machine. Your country included, our machines are used in 39 countries across the world in industrial kitchens.

Our machine was produced in accordance with the international standards. You are strictly advised to read the instructions for use or make the user read these in order to get the best of machine and enjoy a long service life. You are kindly asked to take note of following warnings before you call our service.

SENOVEN

- Please read this manual and make sure the users read it carefully before you install the machine. The machine shall fall out of warranty coverage if you operate the machine without having read the manual beforehand.
- This manual, which contains information regarding the assembly, usage and maintenance of the product purchased, should be read carefully. Make sure that electrical installations for the machine connection be prepared accordingly by qualified personnel in accordance with the legal regulations before our service personnel arrives for appliance assembly.
- In the case of hesitation or where you are not clear about certain issues, please call the nearest authorized service and ask for information.

We kindly remind you that charges and expenses for waiting times shall be billed to you on hourly basis, should you stand the called service personnel up.

IMPORTANT WARNINGS AND SAFETY INSTRUCTIONS:



NOTE: This manual contains important safety, installation and operation instructions. All operators are required to read this manual thoroughly before operating and using the unit. Erroneous installation, setting and maintenance may cause damage to the unit, to injuries or even death.



WARNING: This product is not intended for use by kids or incapable adults. Incapable persons are only allowed to use this product under the supervision of an attending adult once said attending person takes necessary safety measures. It should be ensured that small children do not toy with the product.



WARNING: Erroneous installation, arrangement, replacement or maintenance may cause damage to the unit, to injury or even death. Do not use the product or put into service before reading the instructions for installation, cleaning and maintenance.



ATTENTION! You should not work with long hair, full clothes or dangling jewelry near the belt. Getting caught by the belt may cause serious injury.



ATTENTION! For your safety, do not store or place gas, gasoline or any other imcombustible stuff near the product.



WARNING! If the power line is damaged, do not attempt to operate the product. Immediately contact technical service or call an experienced electrician.



ATTENTION! Do not attempt to broiler the product to be broiled with incombustible stuff like paper. Such attempts may cause fire.



ATTENTION! Do not place any object (hot pan, plate, tray etc.) on any part of the machine other than the belt.



ATTENTION! Always be very careful when using the product.

ELECTRICITY WARNING



It includes information about a possible electricity shock danger. Observations mistakes may cause equipment damages and/or serious injury or even death.

HOT SURFACE WARNING



It includes information about contact with equipment and parts. Failure of compliance may cause body injury.

- The broiler should be placed under a ventilation cover or a hood. Make sure that the broiler is sufficiently aerated, and the ventilation is adequate.
- Make sure that the broiler is adequately distanced from walls and any other incombustible stuff. The minimum required distances are to be found in the following sections.
- Keep the broiler always clean. Remove possibly incombustible substances from the broiler.
- Ventilation gaps should be sufficiently dimensioned, so as to ensure proper ventilation of the broiler.
- Do not block ventilation openings. Do not congest ventilation openings with foreign bodies.
- Broiler shall only be used with the fuel specified on specifications' plate fixed onto it.
- Store the manual in a suitable place, considering that you may need to look at it again in the future.
- Obtain a list from your gas provider which instructs you on what to do when you sense a gas smell. Hang this list on a visible spot.
- Gas won't pass the burner when there's no power.

In addition to the warnings and precautions in this manual, apply the following directives for Senoven Automatic Broiler to operate safely:

- Read and apply all the instructions before using this equipment.
- Use the broiler only for its intended use as described in this manual.
- Do not operate this device if it has a defective cable or plug or if it's otherwise damaged.
- Only authorized personnel is allowed to carry out maintenance or repair work on this device.
Please contact your local Senoven branch.
- Please use only original Senoven spare parts for the broiler. Otherwise the guarantee becomes void and cooking performance may be drastically impaired. Use of parts that are not produce of Senoven affects these criteria and broiler performance may affect part service life and food health safety.

Warnings and instructions below appear throughout the manual and shall be diligently complied with:

- Shut the gas valve for turning the broiler off and unplug before any service, maintenance or cleaning work to be done.
- Wait for the broiler to cool down completely before carrying out any service, maintenance or cleaning. Failure to do so may cause body injuries.
- Procedures in this manual may contain references to use of chemical products. Senoven does not endorse the use of any cleaning / degreasing agent. Make sure to use chemicals that are approved for use in kitchen.
- The broiler should be grounded in accordance with the local electricity codes in order to avoid risk of electricity shock. These fuses are protected by electric circuit breakers. Separate electricity lines require a grounding plug.
- All electrical connections should comply with local electricity codes and other applicable regulations.
- Operate the machine in an adequately ventilated place. Make sure to leave lateral safety clearances in order to avoid the emergence of a fire safety risk. In case of emergency, follow the directives for shutting down.
- Do not attempt to turn on the device in case of power cut.

WARNING: Danger of electrical shock. Failure to comply with these instructions may lead to serious injuries or even death:

- Device needs to be grounded.
- If you have doubts about the proper operation of the device, check with a qualified electrician.
- In order to avoid the risk of serious injury or death on the control box, do not use water in its proximity.

WARNING: Hot surfaces and high temperatures. Failure to follow these procedures may lead to serious injury:

- Make sure to have cooled down the device in accordance with the instructions in this manual before carrying out any cleaning or maintenance work.

IMPORTANT NOTE

Broiler cleanness and overall maintenance status are the key factors that affect the broiler performance. All operations that are to be carried out without applying the instructions in this manual may lead to breakdown of machine parts, thereby exclusion thereof from guarantee coverage, or to injuries or even to death. Therefore, please read the instructions in the manual carefully, understand them and remember that this manual will guide you on the proper use of this product.

Responsibilities of Vendors

In general, the responsibilities of the vendors are as written below:

- To verify that electricity and gas service are applied under conditions required by the manufacturer and to check whether the connections are in conformity with the manufacturer's requirements.
- To take the broiler out of its package as described in instructions for use and operation, install the broiler and place it appropriately.
- To verify that electricity and gas connections are made by a qualified person. To make sure that the connections are implemented in accordance with the applicable provincial / regional / country standards.

CONTENTS

CERTIFICATE OF WARRANTY

PRESENTATION

IMPORTANT WARNINGS AND SAFETY INSTRUCTIONS

PART 1: INTRODUCTION

- 1.1 Definition
- 1.2 Description of Body Elements
- 1.3 Warranty Information
- 1.4 Microprocessor Control
- 1.5 Cooking Feature
- 1.6 Conveyor (Belt)
- 1.7 General Information
- 1.8 Graphical Features
- 1.9 Broiler Electricity -Gas Technical Specifications Table
- 1.10 Dimensioning

PART 2: INSTRUCTIONS FOR USE

- 2.1 Pre-Installation
- 2.2 Assembly
- 2.3 Leveling
- 2.4 Clearance Requirements
- 2.5 Ventilation
- 2.6 General Information About Ventilation
- 2.7 Gas Installation- 1/2" n.P.T
- 2.8 Installing Gas Appliance Connectors and Flexible Gas Lines Correctly
- 2.9 Required Items for Installation
- 2.10 Broiler Electricity -Gas Technical Specifications Table
- 2.11 Restraining Requirements
- 2.12 Pre-Operation Check

PART 3: OPERATING, PROGRAMMING AND SHUTDOWN

3.1 Controls and Indicators

3.2 Operating Procedures

3.3 Operating

3.4 Programming

3.5 Shutdown

3.6 Warnings

3.7 Errors/ Warning Messages

3.8 Temperature Reading Failure (Sensor Failure)

3.9 Temperature Limit Exceeded

3.10 Low Battery Appears on Screen

3.11 Ready

3.12 Ignition Failure

PART 4: CLEANING AND DISASSEMBLY

PART 5: CALCULATION OF TOTAL PRODUCTION YIELD

PART 6: SPARE PARTS MANUALS

PART 7: ELECTRICAL DIAGRAM

PART 8: TROUBLESHOOTING

8.1 Temperature Limit Exceeded

8.2 Low Battery Appears on Screen

8.3 Temperature Reading Failure (Sensor Failure)

8.4 Ignition Failure

8.5 Products are Not Cooking

8.6 How to Call Technical Service

PART 9: LABELS

NOTES

PART 1: INTRODUCTION

1.1 Description:

SENOVEN SEN 3000 (double-belt) brings about Cooking by evenly distributing high-temperature air between its belts. Its air system substantially decreases energy consumption. It's readily cleanable and easy-to-use. Its easy-to-use control panel reduces user errors to a minimum level.

This manual contains safety, assembly and operation instructions For Senoven Automatic Broiler Model SEN 3000. You are advised to read all the information in this manual for an easier installation and use.

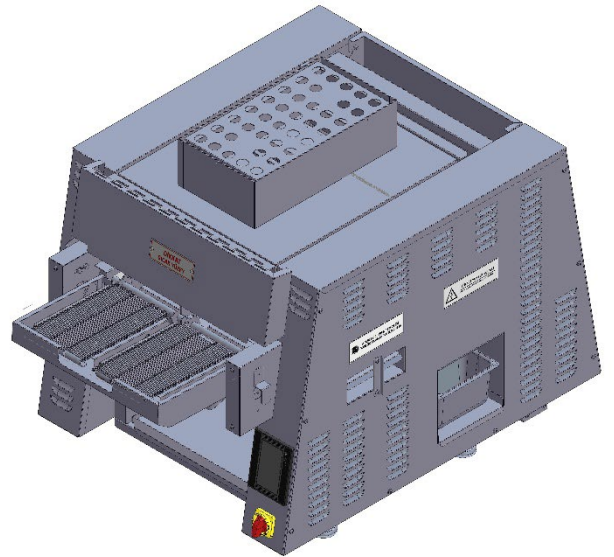

1.2 Description of Body Elements:

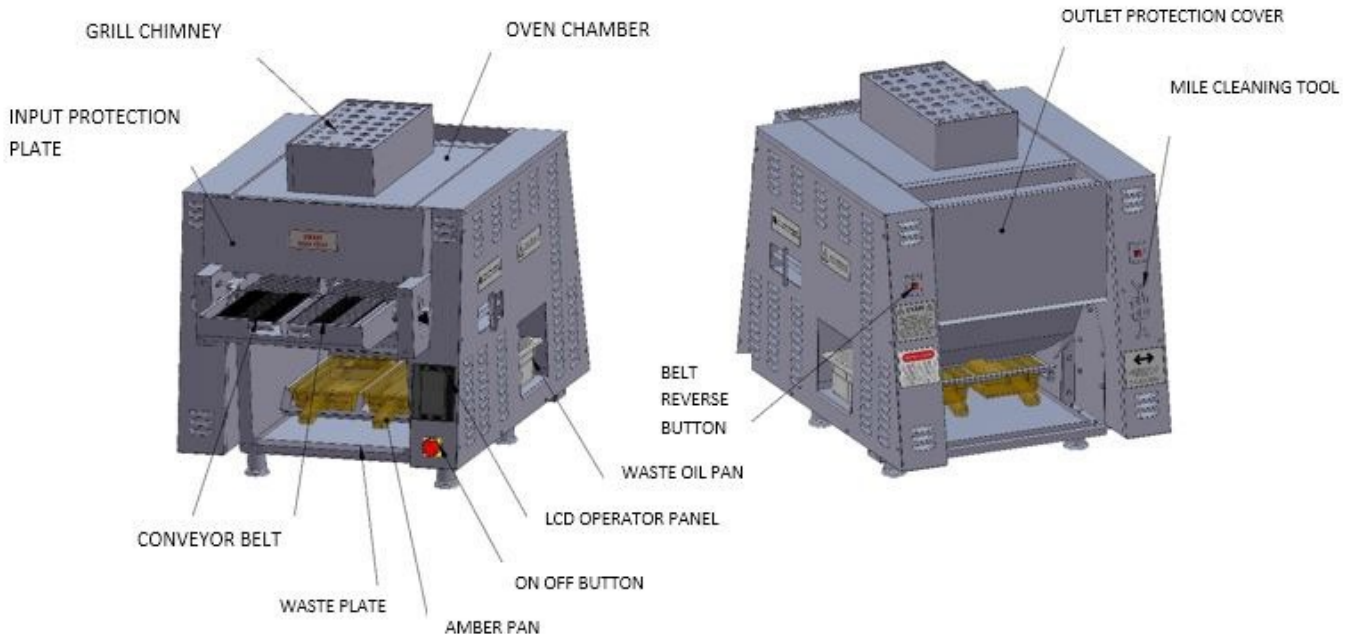

1.3 Warranty Information:

Read warranty content fully. If the unit suffers damage during transportation, immediately contact the shipment company and notify them of the damage. Shipment damages are under the responsibility of receiver and is not covered by the guarantee.

Situations not covered by the guarantee:

- Damages arising during shipment or caused by wrongful usage.
- Damages caused by electric service.
- Damages due to non-compliance with maintenance instructions in the manual.
- Breakdowns resulting from non-compliance with the manual or any other applicable training
- Damages resulting from inappropriate or inadvertent use apart from normal operating procedures specified in this manual.
- Situations where electrical components suffer damage due to humidity.
- Situations arising from external impact or absence of safety precautions.



IMPORTANT!

Keep the user manual in a place where you can readily retrieve it. If the product changes hands, make sure the manual is delivered together with the machine.



ATTENTION!

Şengün Makina reserves the right to change technical specification and configuration. Alterations and improvements in revisions do not apply to previously sold products.

1.4 Microprocessor Control:

The broiler is controlled by a programmable microprocessor. This microprocessor controls all the functions of the broiler. It may be set to any desired temperature between 300 °C and 500 °C. In SEN 3000 automatic broilers, cooking time (conveyor speed) may be adjusted in a range of 1 minute up to 7 minutes. Thanks to program storage feature, all cooked products may be prepared in consistent standards and shorter times.

1.5 Cooking Feature:

Pressurized air circulating in the automatic broiler body makes sure the products are cooked homogenously and quickly with the help of burners.

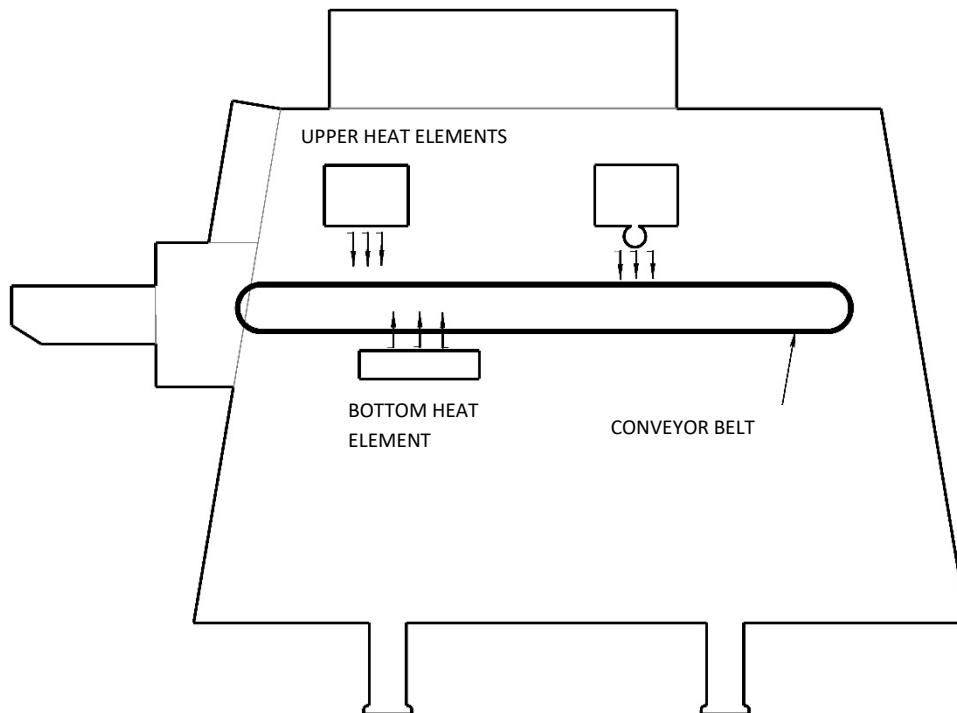

1.6 Conveyor (Belt):

Conveyors enable the product to pass through the broiler. The belt is controlled by microprocessor and in SEN 3000 automatic broilers it may reach a speed between 1 up to 7 minutes. The belt speed determines how long the product will stay in the broiler, which is actually the Cooking time. The width of the belt (left and right belt) is 178 mm. The belt consists of stainless-steel wires which engage each other in a locking manner. It's designed in a spaced manner for an easy circulation of heat and air.

1.7 General Information:

- Instructions below are intended to serve as a guide for you in the installation of the broiler.
- First and foremost, the broiler boxes should be counted and be inspected carefully for any visible damage.
- Prior to installation, proper and safe storage systems should be provided if the broiler requires to be constantly protected against external conditions and humidity.

1.8 Graphical Features:

		SEN 3000
Conveyor belt width	:	178 mm x 2 (right and left)
Usable belt width		152,5 mm x 2 (right and left)
Heating zone (chamber) length	:	512 mm
Cooking chamber dimensions	:	L 508 mm X W 380 mm x H 45 mm
Conveyor cooking zone	:	0,08 m ² x 2
Rough dimensions – Single story at the bottom	:	Automatic broiler width: 690 mm Broiler height: 800 mm Total length: 1087 mm
Net weight	:	113 kg
Transportation Single Oven Weight – Domestic (Machine + Chassis + Packing)	:	207 kg
Transportation Single Oven Weight – Abroad (Machine + Chassis + Packing)	:	200 kg
Transportation Size – Domestic	:	L 1115 mm x W 840 mm x H 1010 mm
Transportation Size – Abroad	:	L 1015 mm x W 745 mm x H 990 mm
Average gas consumption	:	0,65 m ³ / hour
Gas consumption in full capacity	:	1,375 m ³ / hour
Capacity	:	13 kW
Acceptable temperature range	:	300 °C – 500 °C
Conveyor drive system	:	Microprocessor-controlled conveyor control system supporting a variable mains voltage between 208 and 300 Volts
Cooking time	:	Adjustable between 1 min and 7 mins
Insulation, Isolation	:	On both sides
Heat source	:	2 pieces of heater (burner)
Cooking chamber	:	304 stainless steel
Outer body steel	:	304 stainless steel
DB Level	:	< 60 dba
Power		Electricity and gas

1.9 Broiler Electricity – Gas Technical Specifications Table:

BROILER ELECTRICITY – GAS TECHNICAL SPECIFICATIONS TABLE

Voltage	Phase	N	T (PE)	Ampere Loading	Gas Inlet Pressure	Capacity (Kw)	Gas consumption in full capacity	Average gas consumption	BTU
230V 50/60 Hz	1	1	1	3	21 mbar	13 kW	1,375 m ³ / hour	0,65 m ³ /hour	44,000 /hour

POWER SUPPLY: SINGLE PHASE, 230 V AC, 50/60 Hz / 3 Amp: 1Neutral, 1 Ground

IMPORTANT! Electrical inlet connections should be performed according to the arrangement in inlet terminals.

(PHASE TO PHASE– NEUTRAL TO NEUTRAL– GROUND TO GROUND)

NOTE: Specifications can vary or be altered. The information above is only intended for information purposes.

1.10 Dimensioning:

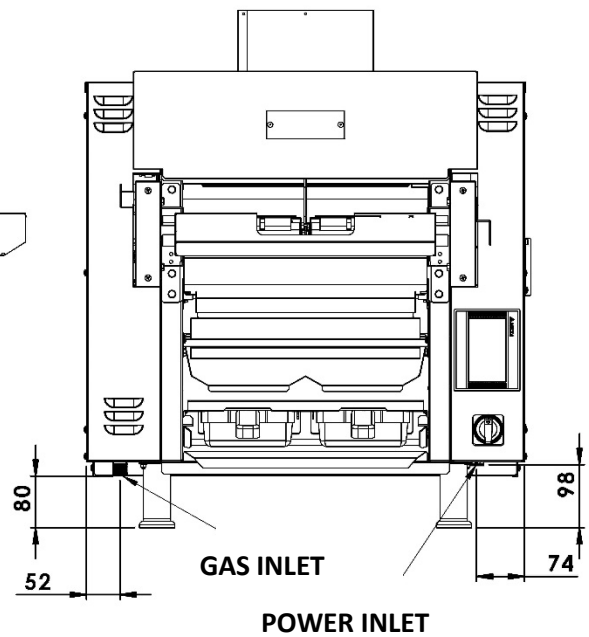
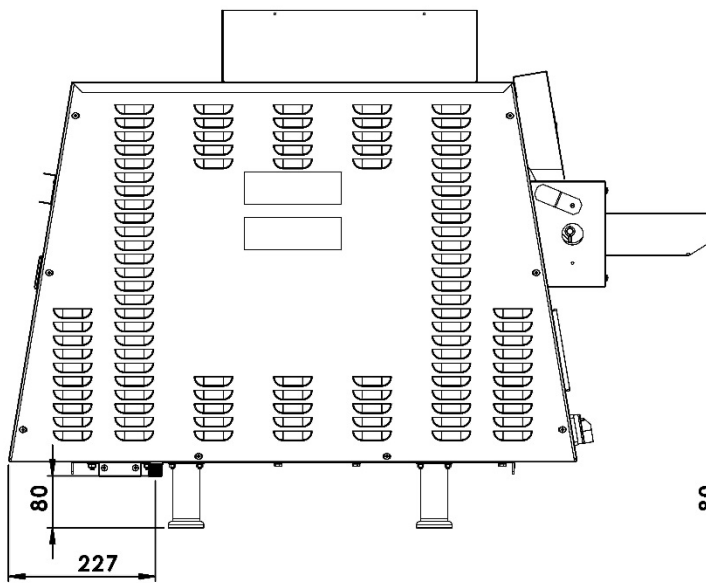
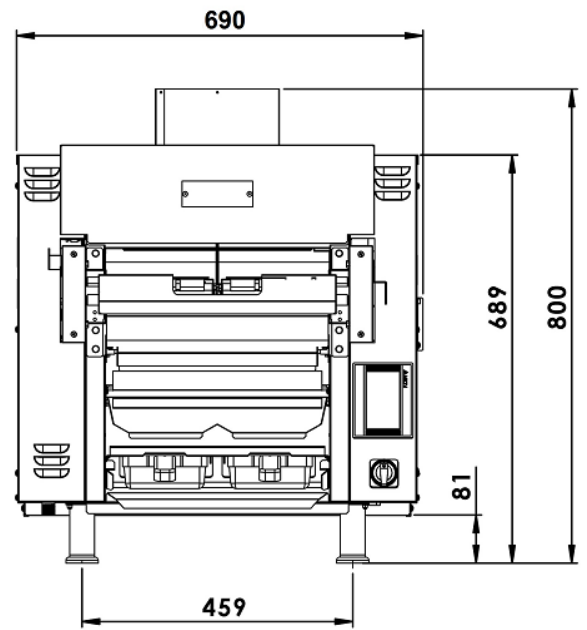
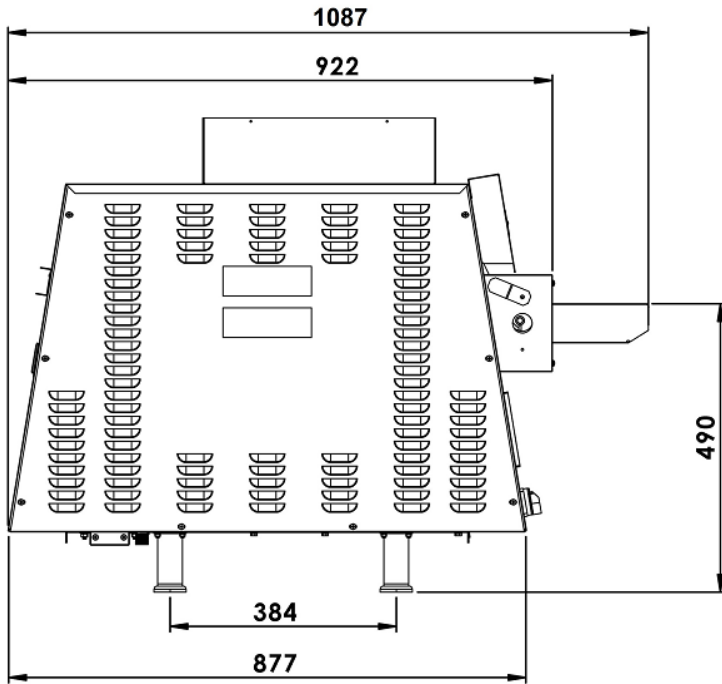

POWER AND GAS INLETS

PART 2: INSTRUCTIONS FOR USE

2.1 Pre-installation:

Broiler parts can move from the place during shipment. Assemble such parts according to their designated places. If any of the parts have suffered an explicit or implicit damage during shipment, the shipping agent shall assume responsibility for such parts. Factory guarantee does not cover shipping damages.

2.2 Assembly:

If installation is not performed by our technical service, please follow the assembly instructions.

2.3 Leveling:

The oil drainage system is based on gravity flow design. Thus, it's crucial for the machine to be fixed on a level surface.

2.4 Clearance Requirements:

Keep combustibles away from the machine zone. Leave 600 mm clearance from surfaces in order to facilitate disassembly and to allow for a comfortable work by technical service.

Required and Recommended Clearances

	Clearance requirement for combustible walls and other structures	Clearance requirement for incombustible walls and other structures	Clearance recommendation for Senoven service and installation
Rear Side of Broiler	300 mm	130 mm	130 mm
Sides of Broiler	300 mm	130 mm	130 mm
Front of Broiler (Feed End)	300 mm	130 mm	600 mm

NOTE: Do not install this broiler in places with ambient temperatures over 40 °C. Otherwise, broiler parts may suffer damage.

Operate the broiler only in approved areas in conformity with instructions to ensure a long service life and a safe operation.

2.5 Ventilation:

This device should be installed under adequate ventilation conditions. Remember that ventilation is of vital importance especially for gas broilers. Determine installation area taking into consideration your country's fire and safety regulations. Guidance information about ventilation shall be given in the next part.

2.6 General Information About Ventilation:

Ventilation duct or hood should be adequate to absorb heat and cooking odors. Moreover, ventilation in gas broilers should be adequate to expel combustion products. Broiler owner bears the responsibility for functional and a duly structured ventilation.

Ventilation opening (hood) should be congruent with general aeration and heating system.

ATTENTION: Do not block combustion and ventilation air flow. Adequate air source should be available for a safe and proper operation of the device.

Now you are ready to set up energy supply for the machine. This shall be done by a competent electrician or installer of your choice.

2.7 Gas Installation - 1/2" n.P.T:

In order to have a safely and efficiently operating broiler, you have to install the broiler properly. Installation should be performed in accordance with national fuel legislation, manufacturer's installation instructions and municipal construction and local construction codes.

1. When the broiler is subjected to pressure test under a pressure higher than 35 mbar, the isolating valve for the broiler and the gas supply line should not disconnect from the gas supply line.
2. When subjected to pressure test under pressures lower than or equal to 35 mbar, the gas supply line should be isolated from the broiler with the help of an isolating valve provided on the gas supply line.

Nominal inlet gas supply should not fall below 15 mbar, which is "the gas supply pressure impacting the broiler connection for natural gas".



2.8 Installing Gas Appliance Connectors and Flexible Gas Lines Correctly:

Proper connection of connectors is vital in terms of ensuring safety and maximum service life in kitchen zone. Connectors should be congruent with standard connector inlets and gas-fueled emergency stop system should be compatible with standard emergency stop systems.

The pipe should be attached with a pipe elbow in order to avoid damages to connector connections due to sharp edges.

For easy movement of the appliance, the connector should be installed with a "lazy" loop for minimum tension.

NOTE: Gas appliances should be disconnected prior to maximum movement. (Minimal movement is possible to connect hose.)

2.9 Required Items for Installation:

1 x 20 ampere (K OTOMAT) – fuses in electrical panel

1,5 mm² cable section for the cable (TTR CABLE – 1 PHASE/ 1 NEUTRAL/ 1 GROUNDING)

NOTE: (TTR Cable is flexible and as such resistant to relaxation and bending during right-left, front-rear movement of the broiler. Our company recommends use of TTR cables.)

The grounding should be robust.

If voltages are high or low, a protected voltage regulator (regulator) is attached.

NOTE: The conditions above should be met for a smooth and quick installation. We ask for your consideration and wish you an enjoyable work.

2.10 Broiler Electricity – Gas Technical Specifications Table:

BROILER ELECTRICITY – GAS TECHNICAL SPECIFICATIONS TABLE

Voltage	Phase	N	T (PE)	Ampere Loading	Gas Inlet Pressure	Capacity (Kw)	Gas consumption in full capacity	Average gas consumption	BTU
230V 50/60 Hz	1	1	1	3	21 mbar	13 kW	1,375 m ³ / hour	0,65 m ³ /hour	44,000 /hour

PORWER SUPPLY: SINGLE PHASE, 230 V AC, 50/60 Hz / 3 Amp: 1 Neutral, 1 Grounding

IMPORTANT! Electrical inlet connections should be performed according to the arrangement in inlet terminals.

(PHASE TO PHASE– NEUTRAL TO NEUTRAL– GROUND TO GROUND)

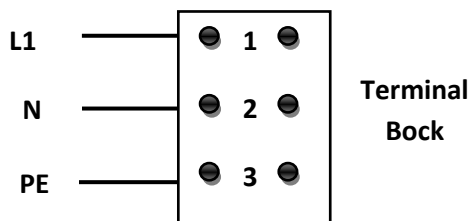

Power requirements are stated on the unit nameplate and must be connected accordingly. This appliance, when installed must be electrically grounded in accordance with local codes, or in the absence of local codes, with the National Electrical Code, as applicable. Before starting the machine, tighten all electrical connections in control box. An electrical wiring diagram can be found inside the control box.

NOTE: Disconnect power before servicing.

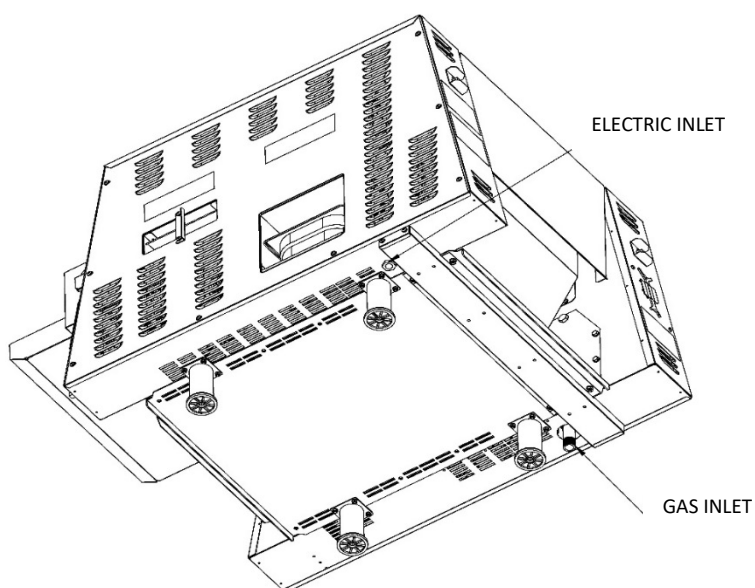

2.11 Restraining Requirements:

1. This installation shall be performed with a gas connection element suited to connection members' standards for movable gas appliances and a fast disconnecting device suited to fast disconnecting standards for gas appliances.
2. Restraining installation should restraint the movement of broiler independent of connector member. Fast disconnecting device or its pipe should restraint broiler movement.
3. If the restraint is dismantled due to cleaning or maintenance, it should be reversed to its original state once the cleaning or maintenance is completed.

NOTE: If restraint connection needs to be disconnected, bring the machine back to its original state once you are done with your work.

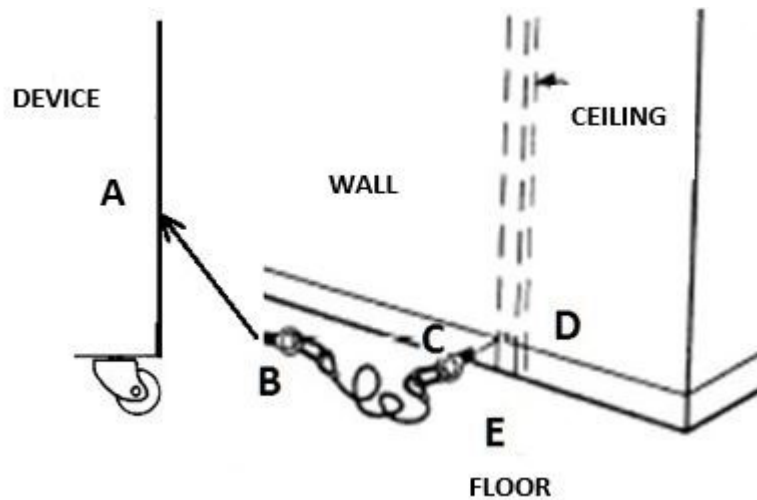

1. Screw part "B" to orifice "A" together with its dedicated cable.
2. Screw part "C" to the support "D" on the wall or to the anchor "E" on the ground together with its dedicated cable.

2.12 Pre-Operation Check:

Be sure that all parts are installed in the proper location:

- Ventilation is turned on
- Broiler is plugged in
- Gas line is connected

DO NOT ATTEMPT TO OPERATE THE BROILER before an authorized technical service personnel or authorized sales representative arrives and checks all the connections and system completely. This service makes sure that the machine connections are properly installed and system functions accurately. Guarantee goes into effect once the installation is approved. The guarantee shall not be effective if the broiler is operated before the check by authorized sales representative or authorized technical service personnel.



ATTENTION! You should not work with long hair, full clothes or dangling jewelry near the belt. Getting caught by the belt may cause serious injury.



ATTENTION! If the power line is damaged, do not attempt to operate the product. Immediately contact technical service or call an experienced electrician.

PART 3: OPERATION, PROGRAMMING AND SHUTDOWN

3.1 Controls and Indicators:

Right Control Box

There's a touch control panel (1). Device settings like belt speed, temperature and the like are controlled on this panel.

Main On / Off Switch (2) serve to turn the machine on and off.

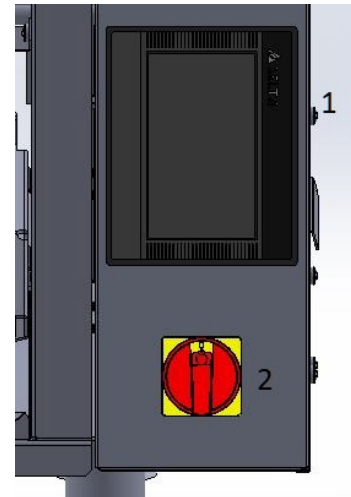

Broiler Rear Side

Belt buttons (a)– Use these buttons to reverse the rotation direction whenever the machine gets jammed. They may also be used during cleaning.

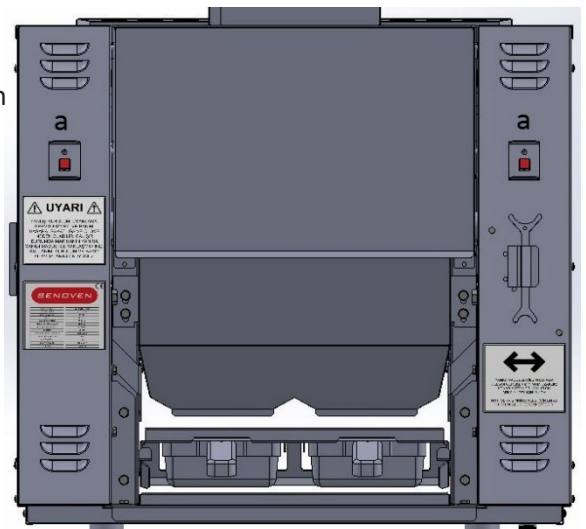

3.2 Operation Procedures:

Pre-Lighting Preparation

1. Center the broiler underneath the hood.
2. Bring the handle to a parallel position with pipe and open gas valve.
3. Turn ventilation system on.



WARNING

THE VENTILATION SYSTEM MUST BE ON AT ALL TIMES DURING BROILER OPERATION. OPERATING BROILER WITHOUT PROPER VENTILATION IS A SEVERE FIRE HAZARD.

3.3 Operation:

Normal Ignition

SB 3000 Automatic Broiler is equipped with automatic ignition. When the broiler is turned on, a hot surface igniter turns on 5 seconds before the flow of gas. Gas then flows to all of the burners. If the burners are not lit within 10 seconds, the control will reset and try again for a duration of 10 seconds. This occurs 3 times. If the broiler does not light after the third attempt, the ignition failure light will flash, and the main on/off switch must be cycled to repeat the procedure. If this still doesn't light the broiler, see the MANUAL IGNITION instructions

1. Turn the MAIN POWER SWITCH (a) on
2. Allow broiler to heat for 45 minutes before cooking.

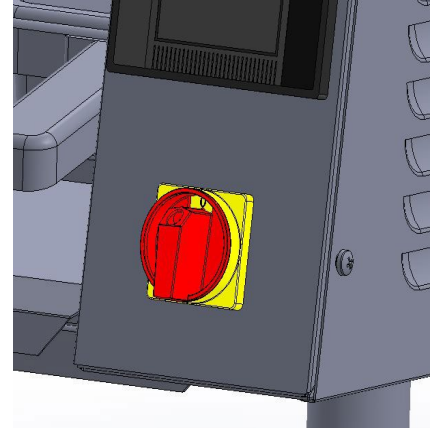

Manual Ignition

Turn the feeder off (if present) and remove the OIL TRAY. Turn the MAIN POWER SWITCH on. Hold a Lighter for upper first burner. Once the first burner is lit, then all burners get ignited.



3.4 Programming:

All functions of the broiler are controlled by a microprocessor. The broiler should be preset for operation. In the following pages, programming is described step by step with reference to exercises. These exercises were prepared with the assumption that the broiler is operated for the first time after installation stage.

Turn the switch on; once it's turned on the operator panel will also turn on and a logo appears on the screen.



Touch the logo image. (The machine won't start to operate unless you touch on the logo image). Then "SELECT" page will appear on the screen.

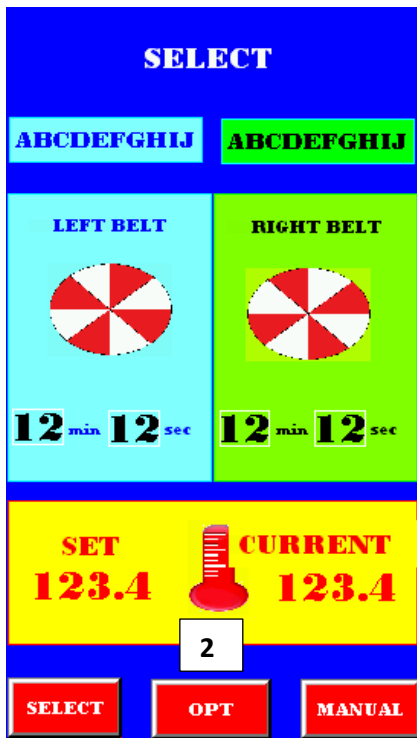

Each time the broiler is turned off and on, it starts with “SELECT” option. The broiler has three different program options to operate with.

SELECT – OPS (OPTIONAL)- MANUAL

“SELECT” OPTION

At first use “SELECT” page is not programmed. For programming touch “SELECT” option on left below. Then the following page will appear.

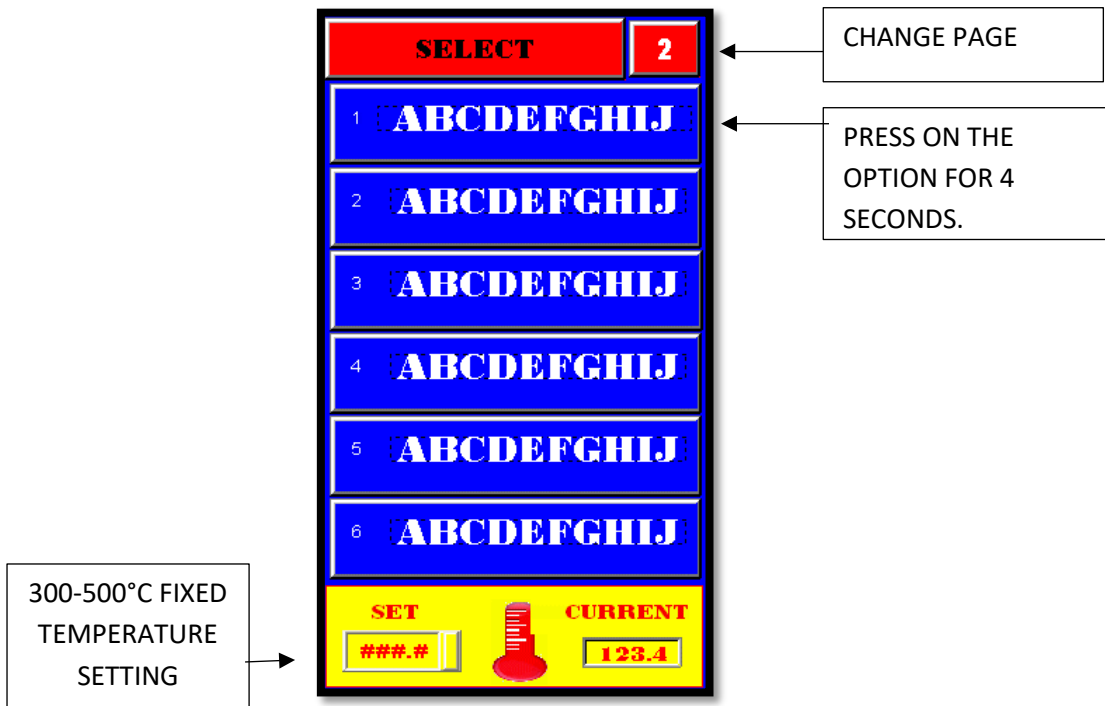

You can switch to programming page by pressing on the option for four seconds as illustrated above. You can program from 1 up to 18 products by pressing on the “change page” option. In “SELECT” option all products cook at a fixed temperature which is set between 300-500 °C. Cooking temperature for all products is common. Simply by changing the cooking time, a standardized cooking can be ensured for the products.

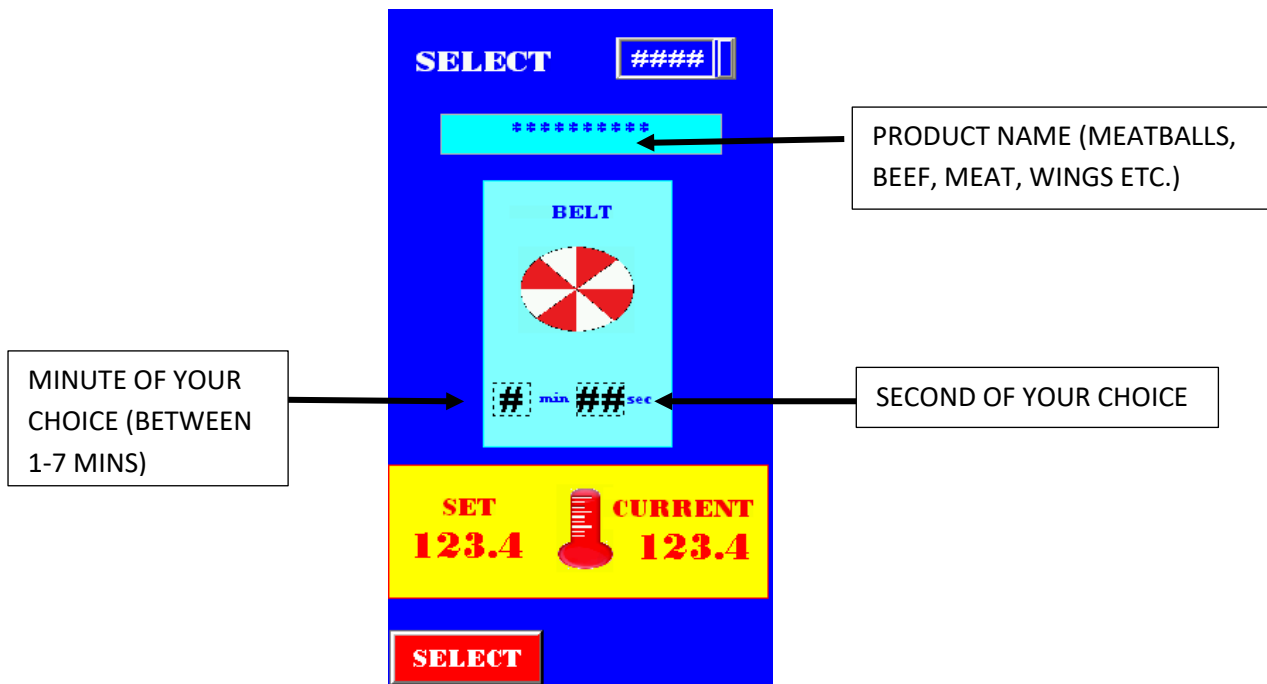

A keyboard will appear on the screen when you touch on the areas (options) depicted above with lines; you can do your programming with the help of this keyboard. Once programming is done, you can go back to “PRODUCTS” screen by touching on “SELECT” option on the left bottom. You can get the broiler ready by pressing on any two of programmed products and “SELECT” option.

NOTE: When the set temperature and the actual temperature of the broiler are equaled, the “READY” caption appears on the screen. Now your automatic broiler is ready to use.

OPS (OPTIONAL) SELECTION

At first use “OPS” page is not programmed. For programming touch “OPS” option on bottom center. Then the following page will appear.

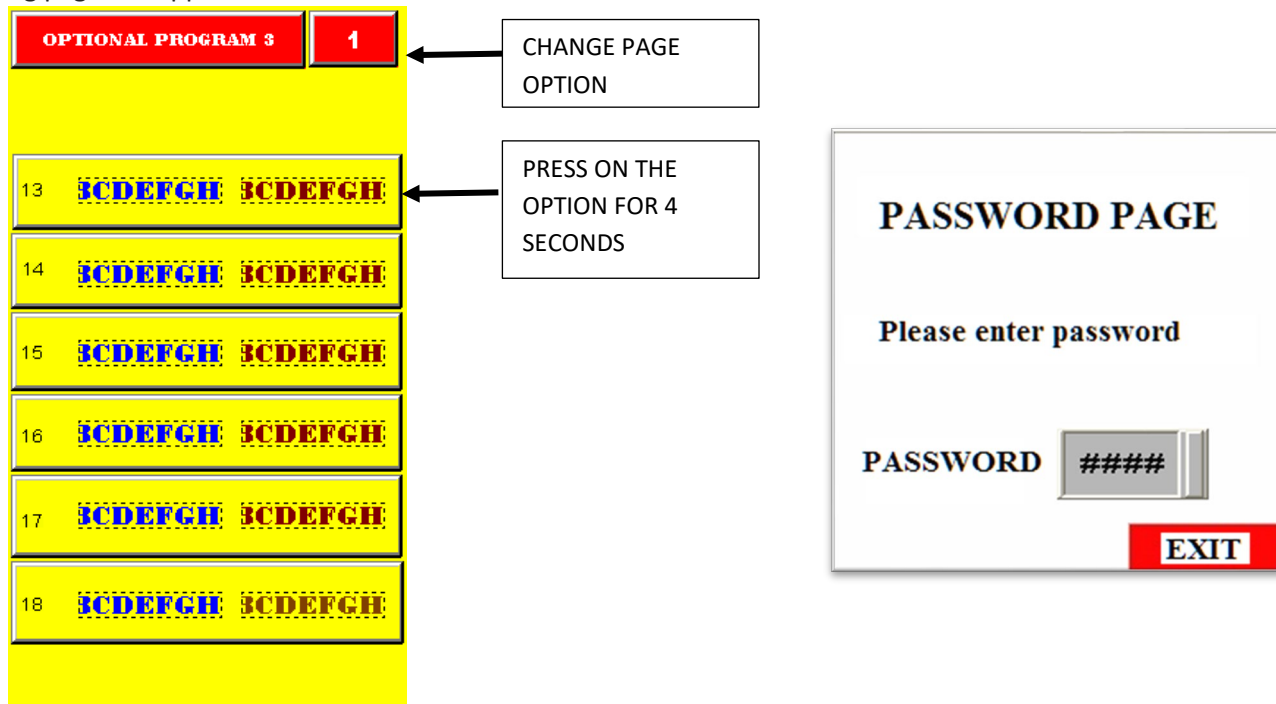

A Password page will appear on the screen when you keep pressing on the option four seconds long. You can access the program page when you click on the password box and enter the password. Once the password is (PASSWORD 5555) entered, do not forget to press on “ENT” key. You can program from 1 up to 18 products by pressing on the “CHANGE PAGE” option.

NOTE: You can leave this page by touching on any one of product programs.

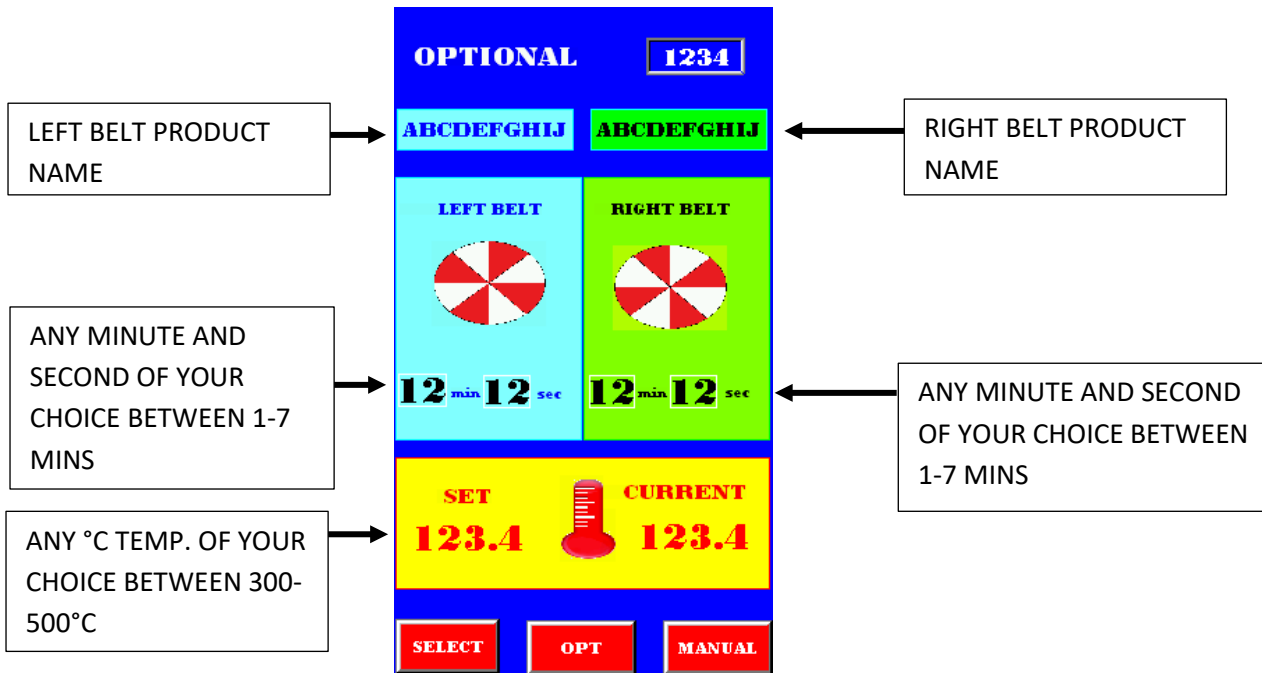

A keyboard will appear on the screen when you touch on the areas (options) depicted above with lines; you can do your programming with the help of this keyboard. Once programming is done, you can switch to “OPS” (OPTIONAL) products screen by touching on “OPS” option on center bottom of the page. You can get the broiler ready by pressing on any of one of programmed products of your choice.

NOTE: When the set temperature and the actual temperature of the broiler are equaled, the “READY” caption appears on the screen. Now your automatic broiler is ready to use.

MANUAL OPTION

Touch on MANUAL option on right bottom of “SELECT” page. Manual control page will appear on the screen.

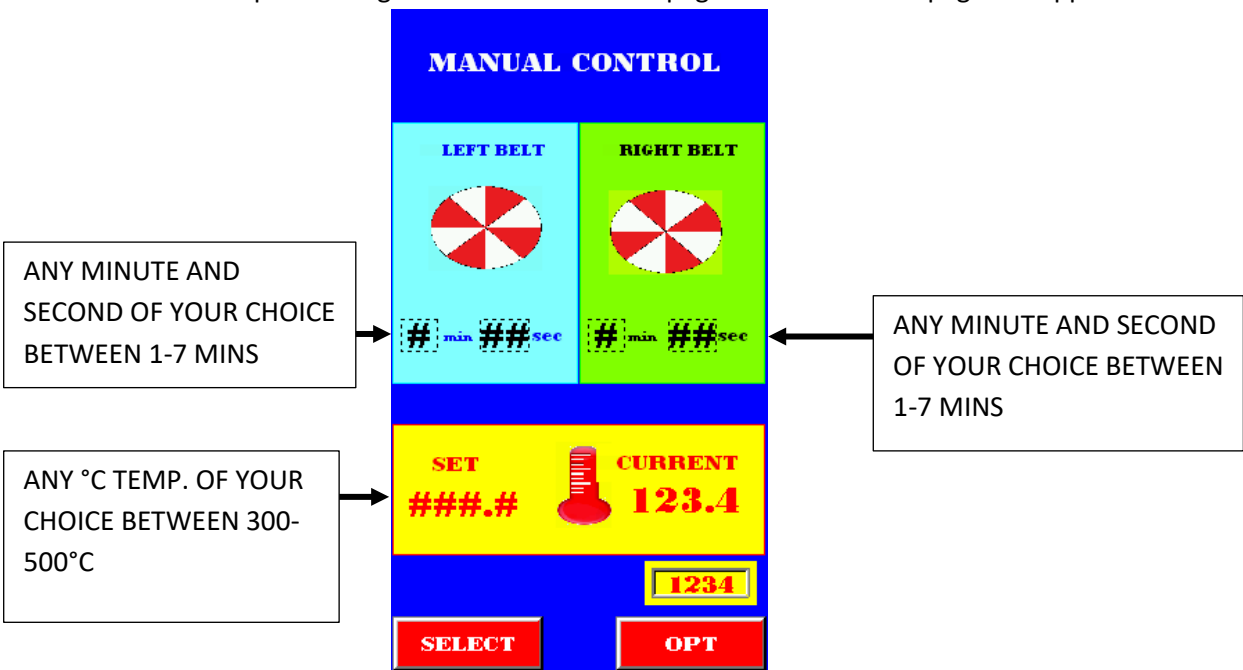

On the manual control page, you can program and readily cook any unprogrammed product of your choice. A keyboard will appear on the screen when you touch on the areas (options) depicted above with lines; you can do your programming with the help of this keyboard. With these options, all of the functions will respond immediately. Manual control feature facilitates trial cookings for new products.

When the set temperature and the actual temperature of the broiler are equaled, the broiler becomes ready to use. You can switch between (SELECT- OPS-MANUAL) operation options with the help of keys at the bottom of the screen.

3.5 Shutdown:

Planned Shutdown

1. Allow the broiler to run free of any product for 10 minutes. This will burn the chain clean.
2. Turn off the main power switch.
3. Wait for 30 mins for the broiler to cool.

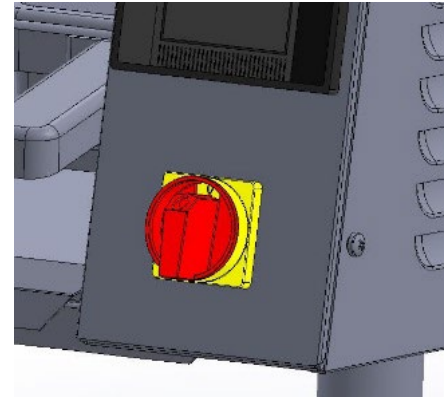



Emergency Shutdown

1. Turn off the main power switch.
2. Close the main gas valve. Valve is closed when it's perpendicular to pipe.

Senoven Automatic Broiler is designed to automatically stop gas flow to the broiler in the event of power failure, gas pressure loss or any other related incident. Do not attempt to operate this appliance in such cases.



 **ATTENTION!** Post instructions to be followed in the event the user smells gas. This information shall be obtained by consulting your local gas supplier.

 **ATTENTION!** For your safety: Do not store or use gasoline or other combustible vapors or liquids in the vicinity of this or any other appliance.

 **ATTENTION!** For your safety: In the event of a prolonged power failure, no attempt should be made to operate this appliance.

3.6 Warnings:

1. The appliance gives “**TEMPERATURE LIMIT EXCEEDED**” alert when broiler temperature exceeds the limit value specified by the manufacturer.
2. If the product does not cook, check cooking times and temperature setting. It may be that the conveyor belt is revolving fast.
3. If the product overcooks, check cooking times and temperature setting. Conveyor belt may be slow.
4. If the product still does not cook or overheats in spite of the fact that all the settings are normal, the manufacturer should be contacted.
5. If problems occur in normal ignition during normal operation of the broiler, manual ignition can be activated (See p. 20)

3.7 Error / Warning Messages:

Our appliances have controlled error/warning messages. An unexpected error that could arise during broiler operation will appear on the screen (control panel) as shown below.

3.8 Temperature Reading Failure (Sensor Failure):

This message appears on the screen if no temperature data is transmitted from cooking chamber to the control unit.

3.9 Temperature Limit Exceeded:

This warning shows up if the broiler temperature exceeds 550 °C.

3.10 Low Battery Appears on The Screen:

This warning shows up when screen battery is low.

3.11 Ready:

This appears when the broiler temperature reaches the desired level.

3.12 Ignition Failure

This warning appears when broiler is not ignited, or a failure occurs in burner system.

PART 4: CLEANING AND DISASSEMBLY

Turn broiler off and close the main gas valve. Disconnect the power supply to the broiler before cleaning or servicing. Make sure the power does not turn itself on again. A failure at the stage may lead to electric shocks, loss of limb or even death. If this broiler is connected using a restraint, and disconnection of the restraint is necessary for cleaning or moving the broiler, the restraint must be reconnected after the broiler has been returned to its originally installed position. Allow to cool for 30 minutes prior to cleaning/disassembly. Use only approved cleaning, degreasing and sanitizing solutions.

The broiler was designed for easy and comfortable servicing as a result of extensive engineering work. Greasing is not required for this broiler.

You have to keep the broiler clean in order to use the broiler in a most effective way. See below for cleaning instructions. Cleaning frequency was determined according to factory recommendations. Your mode of use and product type will be decisive for your cleaning frequency. All electrical parts must be free of humidity.

It's important to wipe and clean the broiler carefully. Do not ever empty a bucket full of water onto the broiler. Furthermore, do not subject the broiler to any pressure resulting possibly from cleaning. This pressure may result from hose-washing or pressurized spray. If any liquid or water is spilled onto the broiler, do not turn broiler power on before you make sure no liquid has entered the control box. If you have doubts about this, contact the technical service.



WARNING! Do not use strong detergents, steel wool or wire brush on unspecified, stainless steel surfaces.



WARNING! Leave the ventilation on during cooling. Failure to do so may pose fire safety hazard.



WARNING! Broiler parts are hot. Do not attempt to disassemble broiler until it's fully cool. Failure to follow this instruction may lead to severe injury.

All parts are cleaned on daily basis unless otherwise stated. Follow the steps for proper assembly. Reverse the order for reassembly.

Required Tools

- Compartment sink
- Degreaser
- Heat resistant gloves
- Scrub pad
- Non-scratch cloth
- Soft bristle
- Small orifice brush
- Large orifice brush
- Shaft cleaning tool

Instructions

1. Allow the broiler to run free of product 10 minutes before turning it off. This allows any residue on chains to burn off.
2. Shut the broiler off and let it cool for 30 minutes before disassembly.
3. Close the main gas valve and unplug the broiler before cleaning.

FEEDER BELT

Tools

- Compartment sink
- Scrub pad

CLEANING: Every four hours at the end of use.

Instructions

1. Pull the release pin.
2. Lift push-bar and belt wire feeder up and remove.
3. Wash, rinse and sanitize in 3-compartment sink.



Do not lift the feeder base together with feeder bar. This will damage the feeder base.

REASSEMBLY: Pull the release pin and place on the feeder base.

Release pins
(every two weeks)

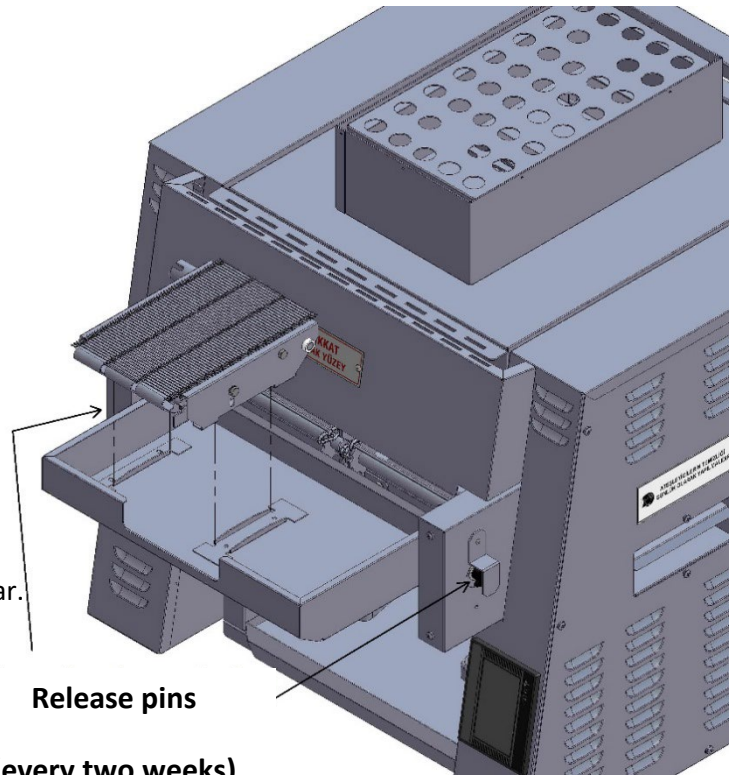

FEEDER HOUSING

Tools

- Compartment sink
- Scrub pad

CLEANING: Daily

Instructions

1. Lift and remove.
2. Wash, rinse and sanitize in 3-compartment sink.

REASSEMBLY: Hang feeder housing on brackets.

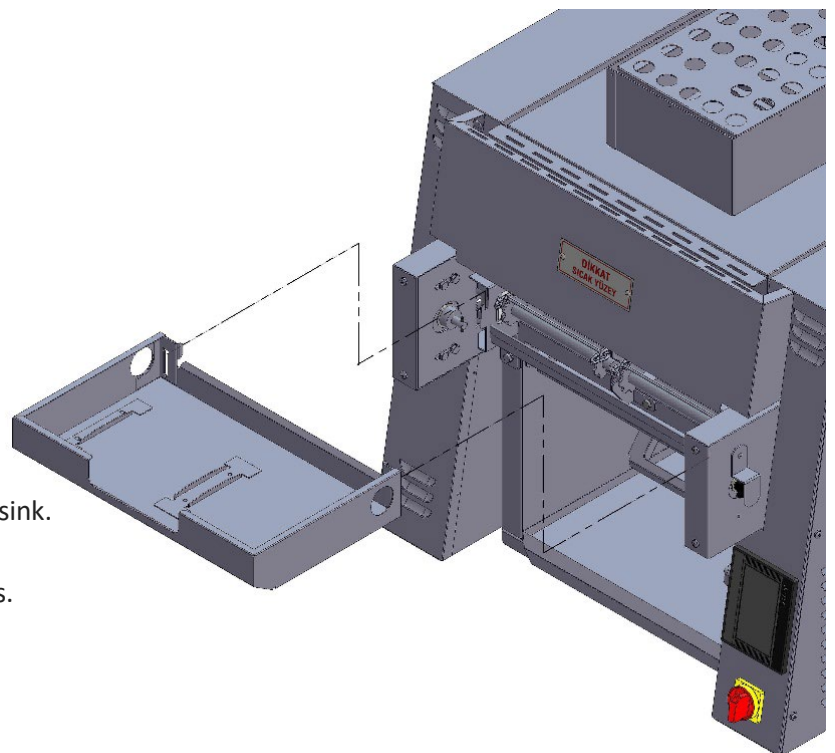

OIL PAN

Tools

- Compartment sink
- Scrub pad
- Heat-resistant gloves
- Degreaser

CLEANING: Daily

Instructions

1. Slide grease pan out.



Make sure the grease pan is fully cool before washing the grease pan.

2. Transfer to sink area and wipe with degreaser.
3. Wash with a scrub pad, rinse and sanitize in 3-compartment sink.

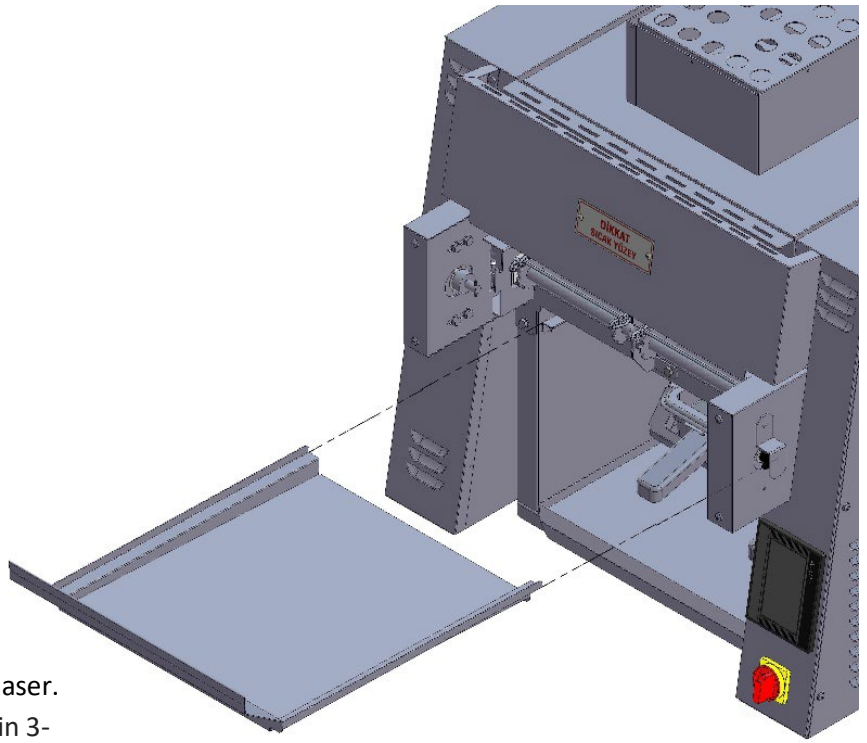

SERVICING PAN HOLDER

Tools

- Compartment sink
- Scrub pad
- Heat-resistant gloves
- Degreaser

CLEANING: Daily

Instructions

1. Pull elbow out and remove.
2. Transfer to sink area and wipe with degreaser.
3. Wash with a scrub pad, rinse and sanitize in 3-compartment sink.

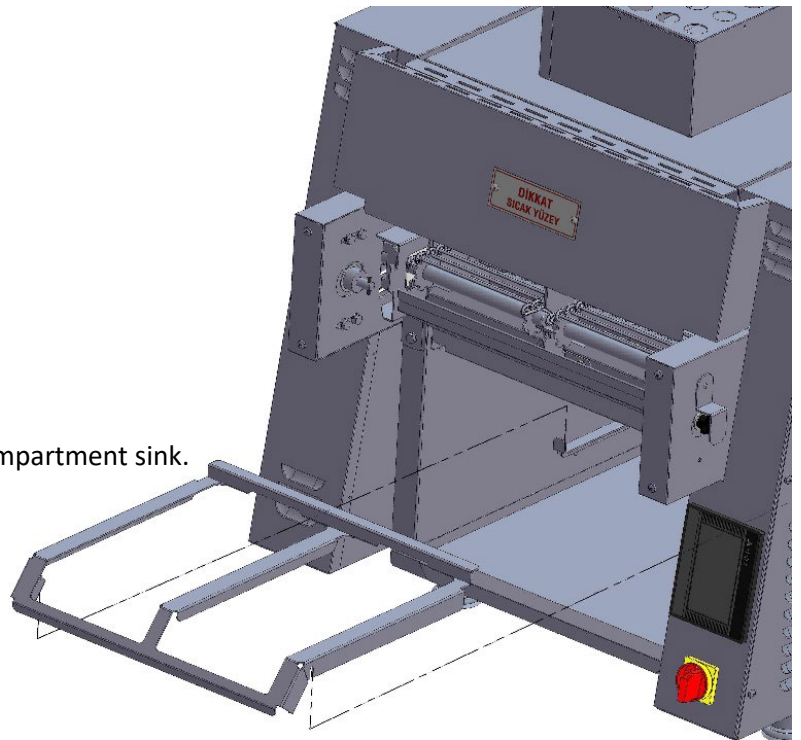

CRUMB TRAY

Tools

- Compartment sink
- Scrub pad
- Heat-resistant gloves
- Degreaser

CLEANING: Daily

Instructions

1. Slide crumb tray out.
2. Transfer to sink area and spray with degreaser.
3. Wash with a scrub pad and sanitize in 3-compartment sink.

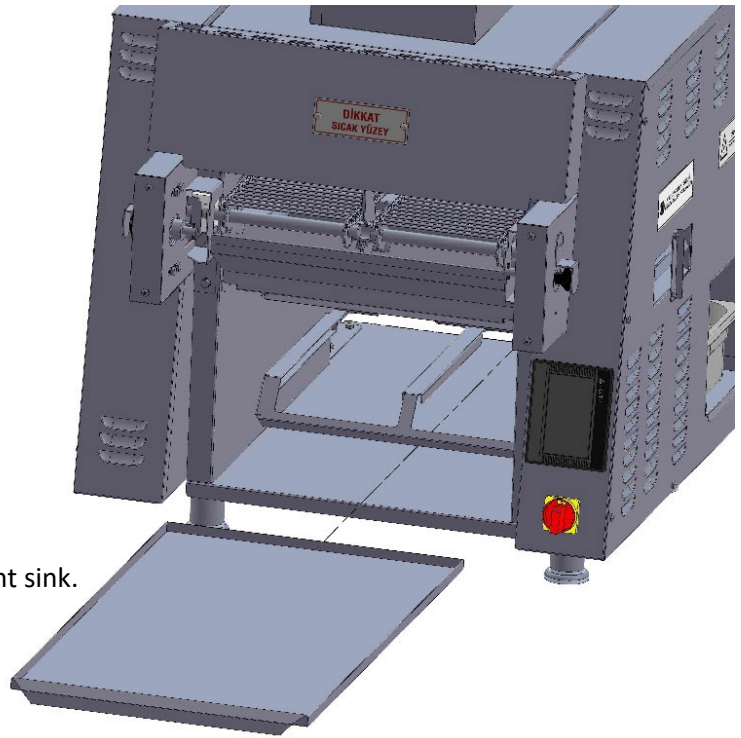

PRODUCT HOLDING AREA

Tools

- Soapy towel
- Sanitized towel

CLEANING: Daily

Instructions

1. Clean product holding area while still warm.
2. Wring out a soapy towel and wash product holding area.
3. Wash product holding area with sanitized towel.



HEAT SHIELD

Tools

- Compartment sink
- Scrub pad
- Heat-resistant gloves
- Degreaser

CLEANING: Daily

Instructions

1. Lift up and take out.
2. Transfer to sink area and wipe with degreaser.
3. Wash, rinse and sanitize in 3-compartment sink.

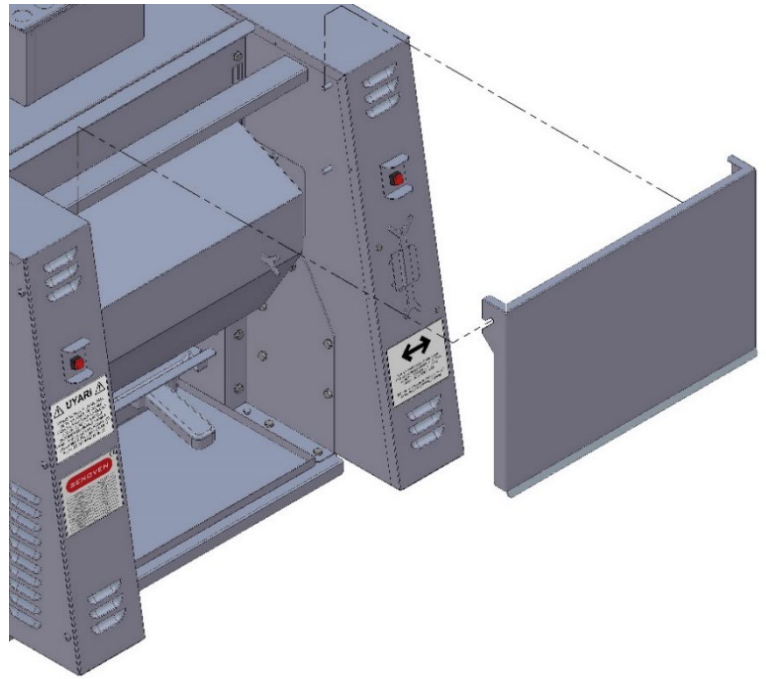

PRODUCT ROTATION PLATE

Tools

- Compartment sink
- Scrub pad
- Heat-resistant gloves
- Degreaser

CLEANING: Daily

Instructions

1. Detach from hook pins and remove cover.
2. Transfer to sink area and spray with degreaser.
3. Wash, rinse and sanitize in 3-compartment sink.

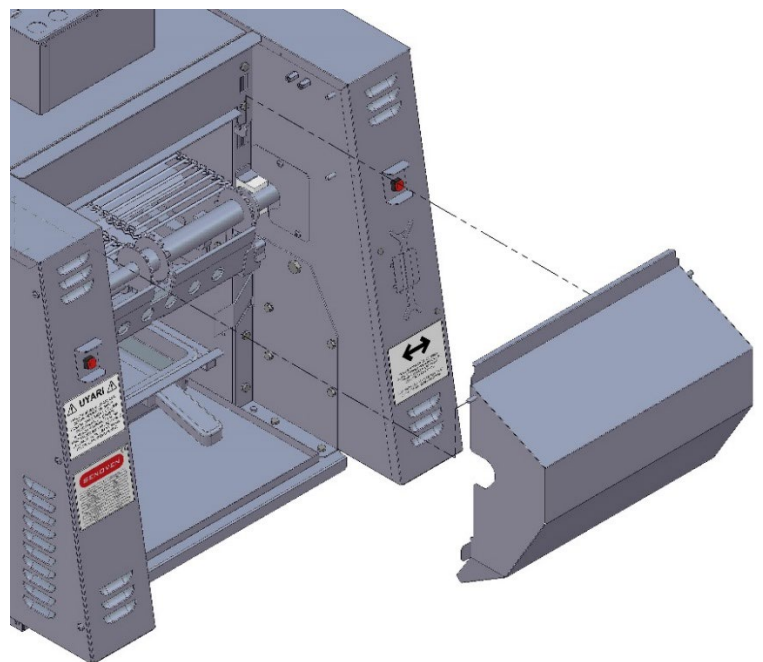

REASSEMBLY: Make sure parts sit and lock properly in the place.

STRIPPER BLADE

Tools

- Compartment sink
- Scrub pad
- Heat-resistant gloves
- Degreaser

CLEANING: Daily

Instructions

1. Tilt stripper blade lift off brackets.



Make sure stripper blade is cool before putting in water.

2. Transfer to sink area and spray with degreaser.
3. Wash, rinse and sanitize in 3-compartment sink.

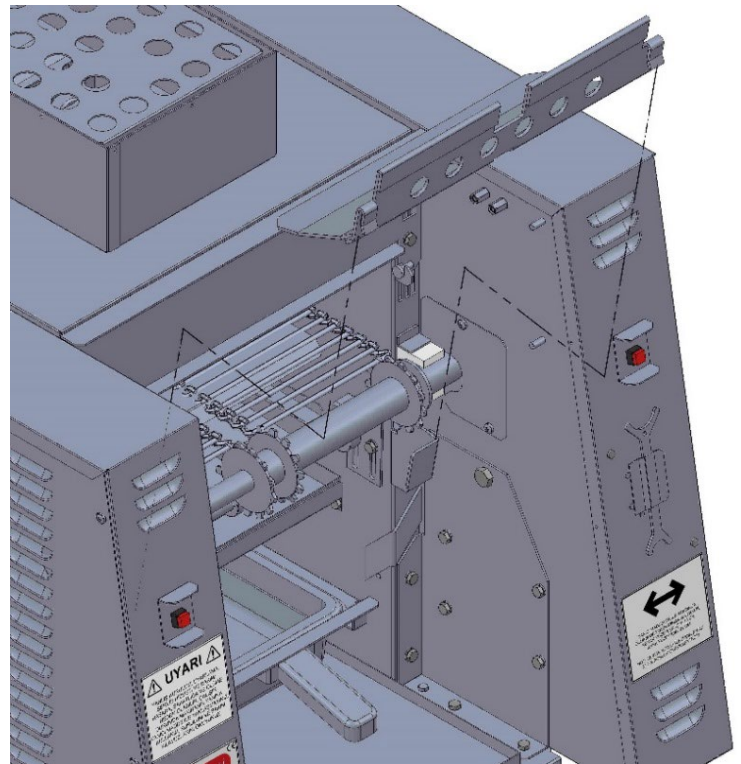

REASSEMBLY: Hang stripper blade on brackets.

GREASE BOX

Tools

- Compartment sink
- Scrub pad
- Heat-resistant gloves
- Degreaser

CLEANING: Daily

Instructions

1. Lift and remove grease box.
2. Transfer to sink area and spray with degreaser.
3. Wash with scrub pad, rinse and sanitize in compartment sink.

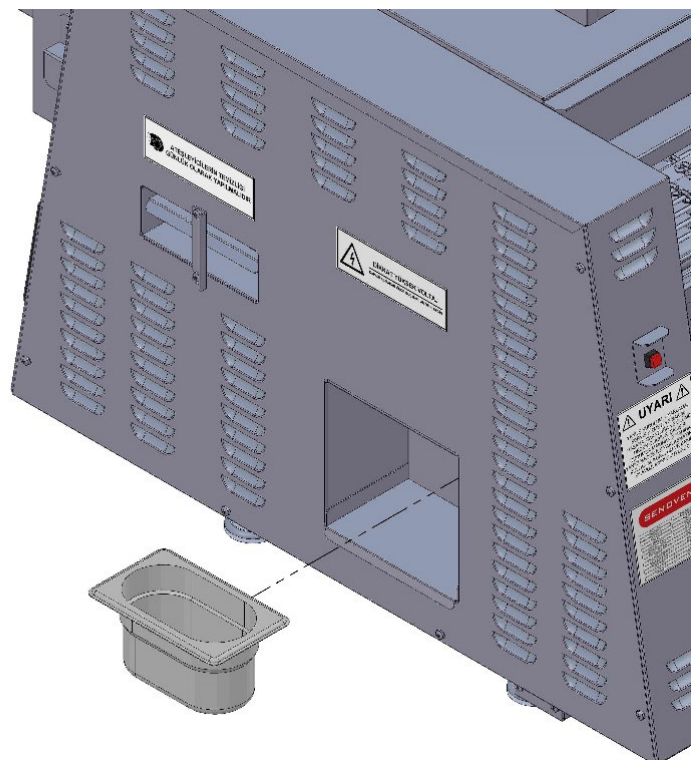

GREASE TROUGH

Tools

- Compartment sink
- Scrub pad
- Heat-resistant gloves
- Degreaser

CLEANING: Daily

Instructions

1. Lift and slide the grease trough out of the broiler.
2. Transfer to sink area and spray with degreaser.
3. Wash with scrub pad, rinse and sanitize in 3 compartment sinks.

REASSEMBLY: Make sure the grease trough is pushed all the way into the broiler.

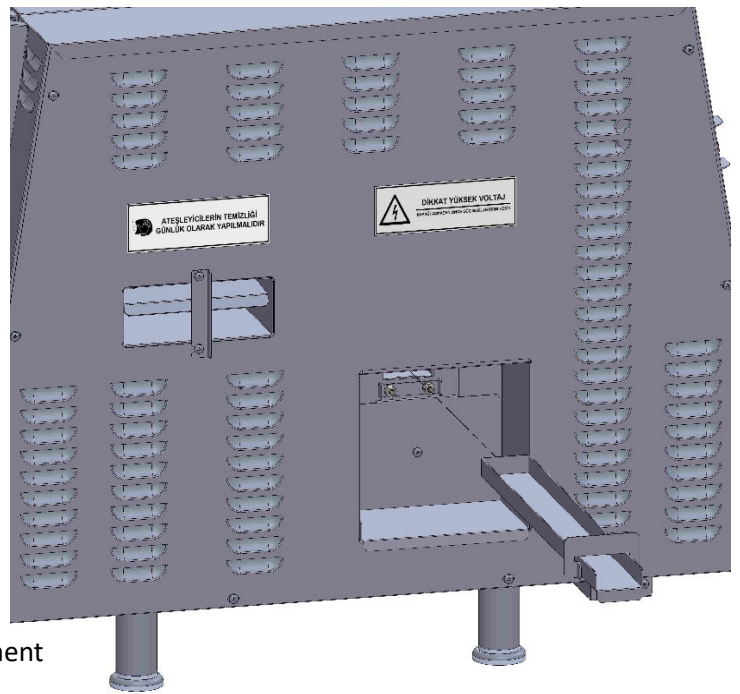

LOWER BURNER

Tools

- Compartment sink
- Scrub pad
- Heat-resistant gloves

CLEANING: Daily

Instructions

1. Pull burner out.
2. Transfer to 3-compartment sink and scrub with a scrub pad or nylon brush.
3. If necessary use a stiff toothbrush to clean any clogged burner holes.

REASSEMBLY: Be sure the holes on the burner are facing up.



Burners must be completely dry before reassembly. Dry with a paper towel.

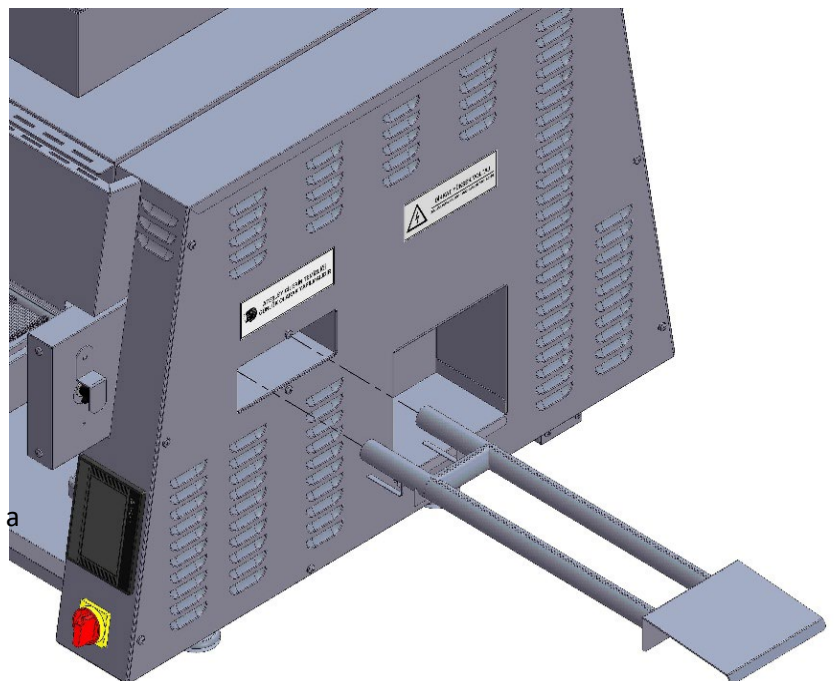

PERFORATED CAP

Tools

- Compartment sink
- Scrub pad
- Heat-resistant gloves
- Degreaser

CLEANING: Monthly

Instructions



EXTREMELY HOT! Be careful not to burn yourself.

1. Lift cap.
2. Transfer to sink area and spray with degreaser.
3. Wash, rinse and sanitize in 3-compartment sink.

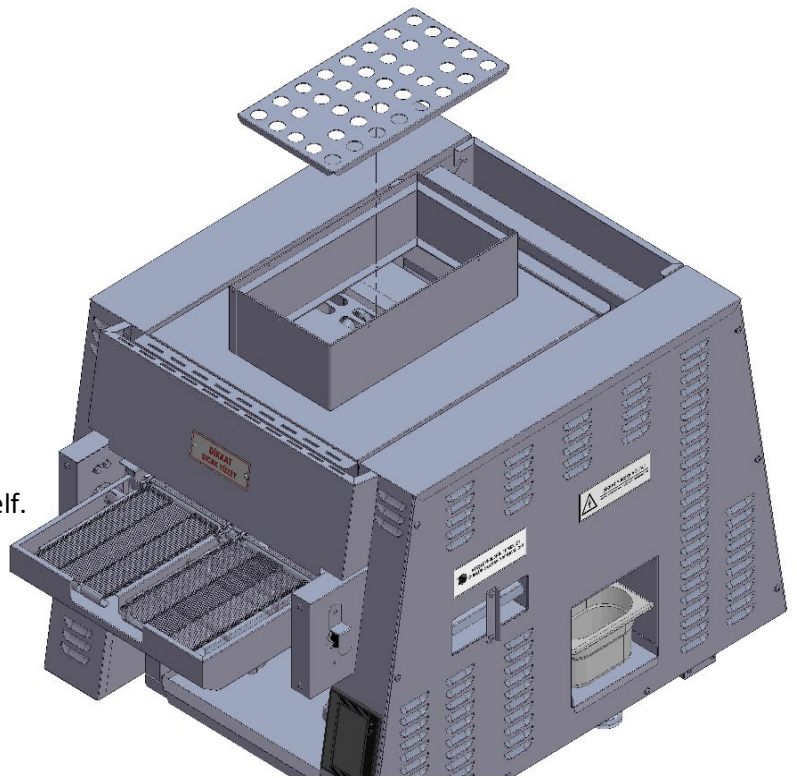

UPPER BURNERS

Tools

- Compartment sink
- Scrub pad
- Heat-resistant gloves

CLEANING: Monthly

Instructions

1. Lift air manifold and burner.
2. Use a stiff brush to clean any clogged burner holes.



Make sure that both air box assemblies are installed and sit flush on their brackets.

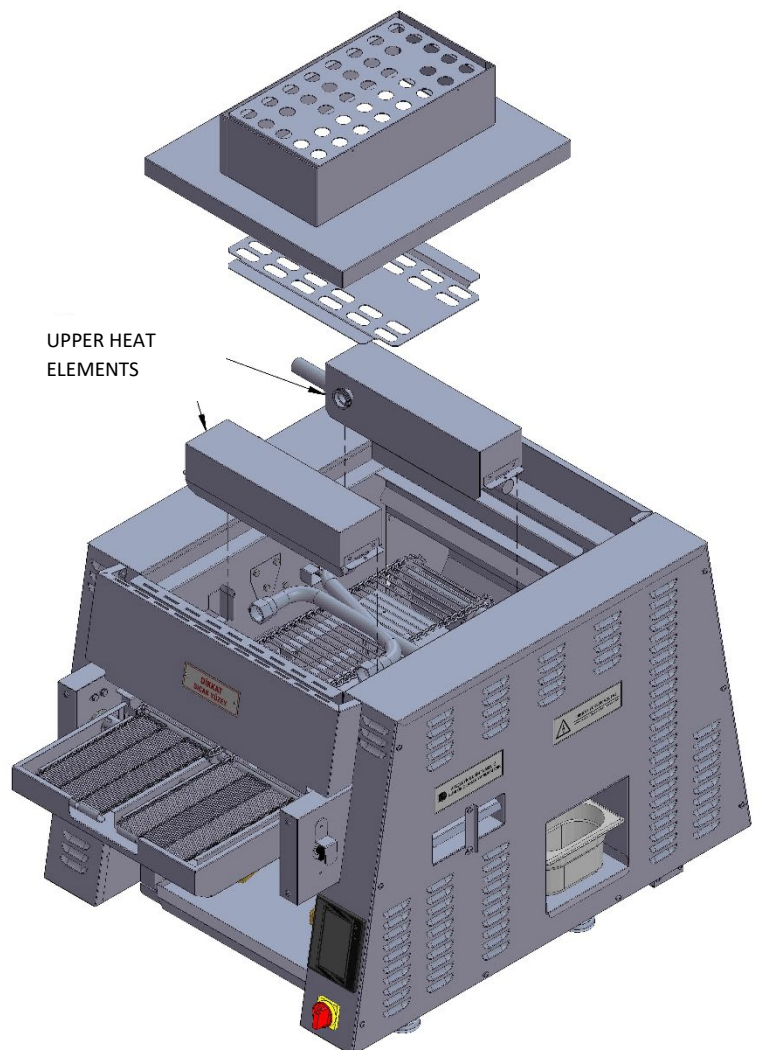

CHAIN SHAFTS

Tools



- Shaft cleaning tool

CLEANING: Daily

Instructions

1. Scrape clean each shaft gap on the belt.
2. Wipe shaft cleaning with a towel.

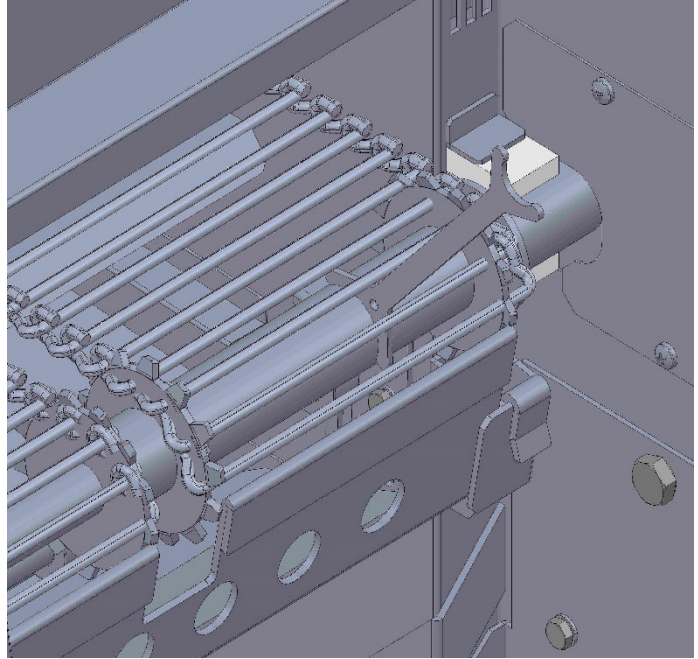

NOTE: Make sure that ventilation opening (hood) is cleaned according to specifications of the ventilation equipment manufacturer.

Preventive Maintenance

Although our broiler is designed to be problem-free, preventive maintenance is important to keep the performance at high level. It's crucial to keep engines, fans, electronic control units free of dust and contamination. Overheating may shorten the service life of parts and may lead to parts' failure.

The frequency of preventive maintenance depends on the environment in which the broiler operates.

Contact and consult with the authorized service to establish a regular preventive maintenance interval suitable for you.

PART 5: CALCULATION OF TOTAL PRODUCTION YIELD

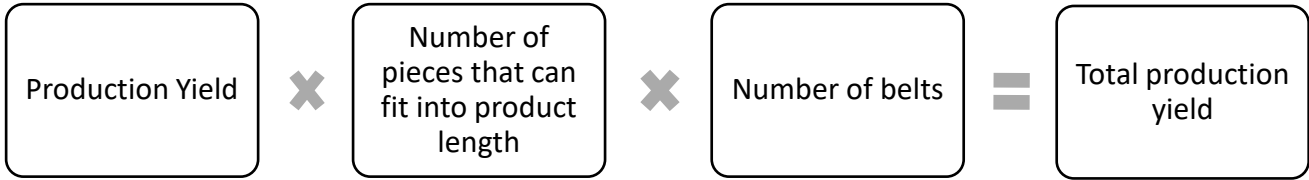
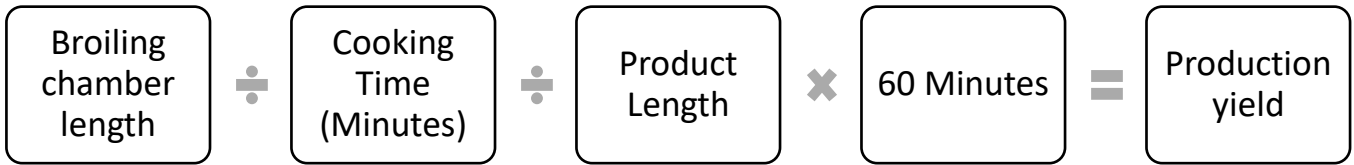

Example 1:

Broiling Chamber Length: 512 mm.

Cooking Time: 2 mins

Product Length: 50 mm.

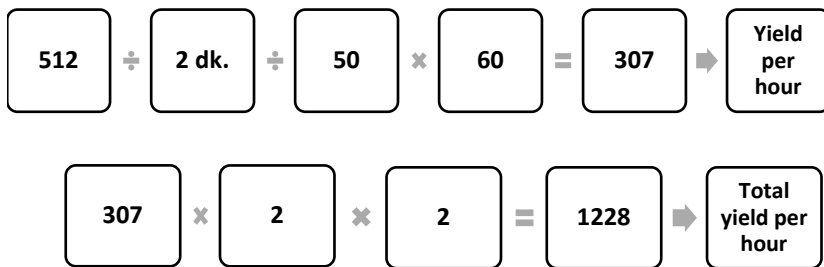

Product Length (A)

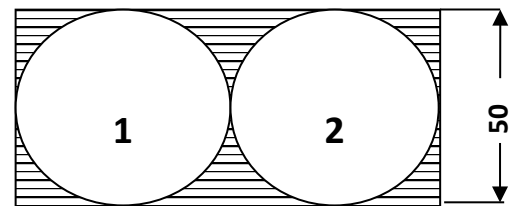

Example 2:

Broiling Chamber Length: 512 mm.

Cooking Time: 5 mins.

Product Length: 100 mm.

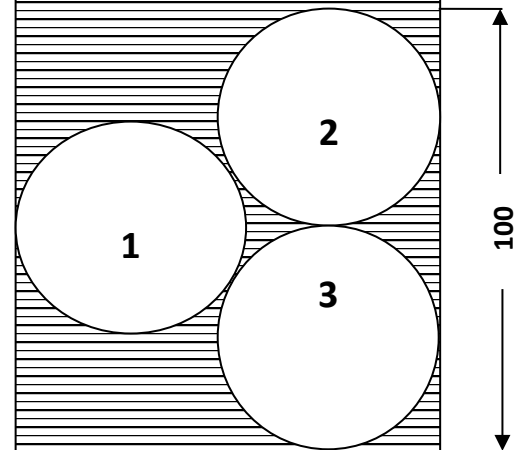
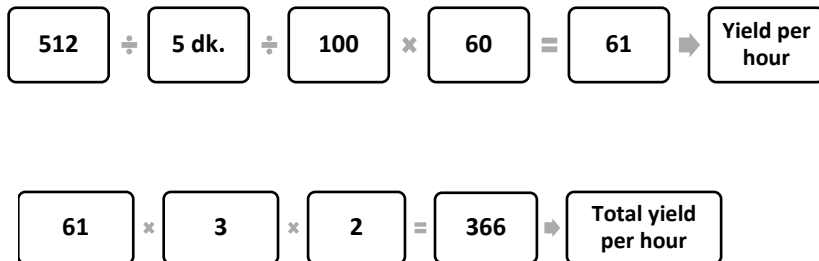

Product Length (B)

BROILER MODEL	BELT WIDTH	USABLE BELT WIDTH	COOKING ZONE	Product E /hour	Product F /hour	Product G /hour	Product H /hour	Product I /hour	Product J /hour
SEN 3000	Single 355,5	330 mm	512mm	90	140	130	900	12	1060
	Double 78/178	152,5/152,5 mm	512mm	90	140	130	900	12	1060
PRODUCT E'	Fresh, deboned, skinless, wrapped, 170 g, 15,3 cm X 10,2 cm X 2 cm Chicken breast- 4 mins 30 seconds cooking time								
PRODUCT	Fresh, lean, 225 g, 17,8 cm X 7,6 cm X 2,5 cm beefsteak - 4 mins cooking time								
PRODUCT	Fresh shish kebab, 20 cm X 2,5 cm, 2,5 cm cuboid-chopped beefsteak - 4 mins 30 seconds cooking time								
PRODUCT	Fresh sausage (pre- cooked), 15 cm X 2,5 cm diameter, re-heating for flavor - 1 mins 20 seconds cooking time								
PRODUCT 'I'	Fresh rib slices (pre-cooked), 2,5 cm X 12,7 cm X 2,5 cm, re-heating for flavor - 2 mins cooking time								
PRODUCT 'J'	Fresh chicken wings (pre-cooked), 7,6 cm x 2,5 cm, re-heating for flavor - 3 mins cooking time								
<p>*Stated values are estimated cooking times. – Initial product temperature, Product variances, Broiler position, Ambient temperature, Results may vary.</p> <p>1 oz = 28,35 g / 1 inch = 25,4 mm / 1 btu / hour = 0.00029307107 kilowatt /</p>									

SPARE PART 1

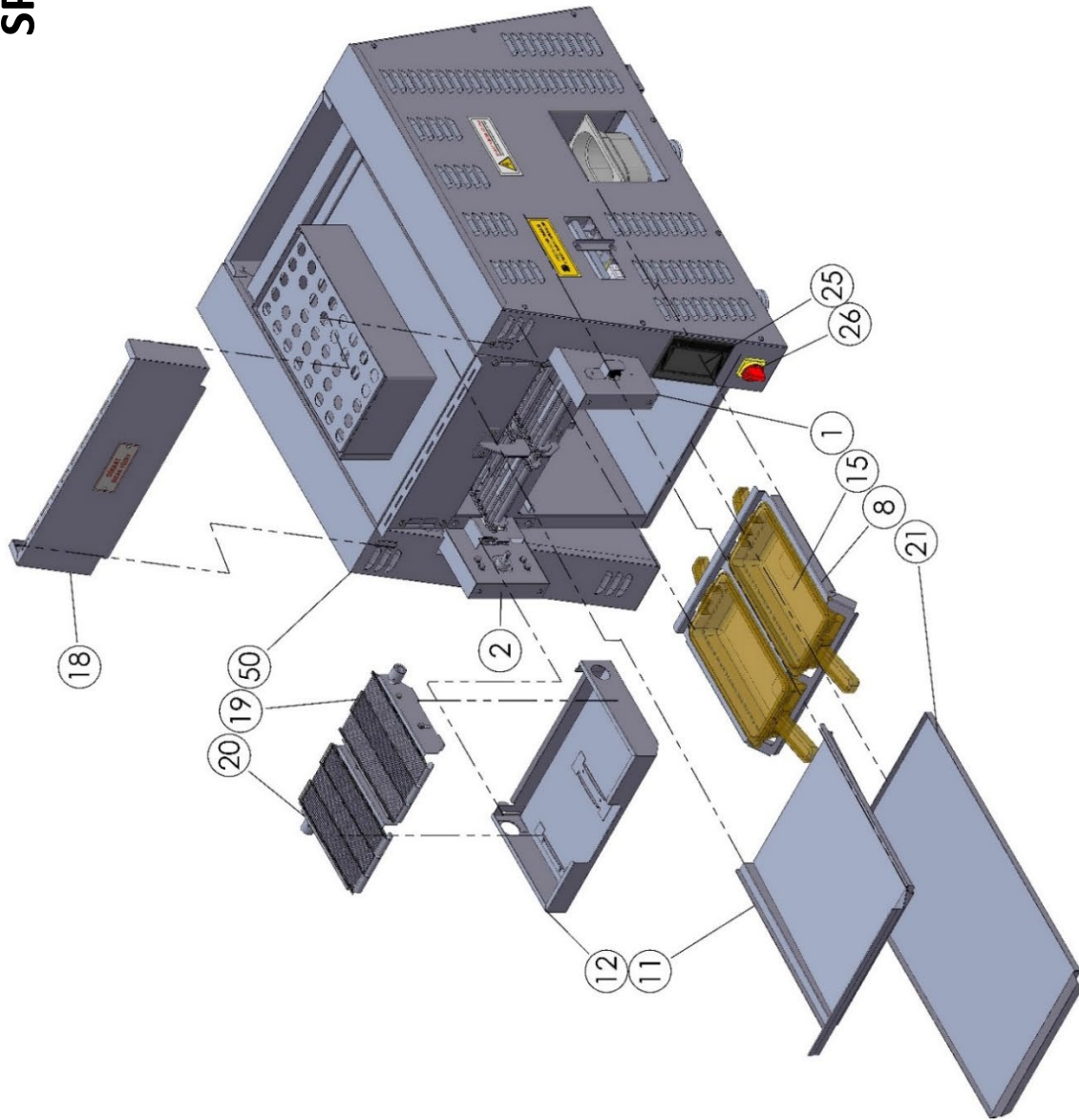

SPARE PART 2

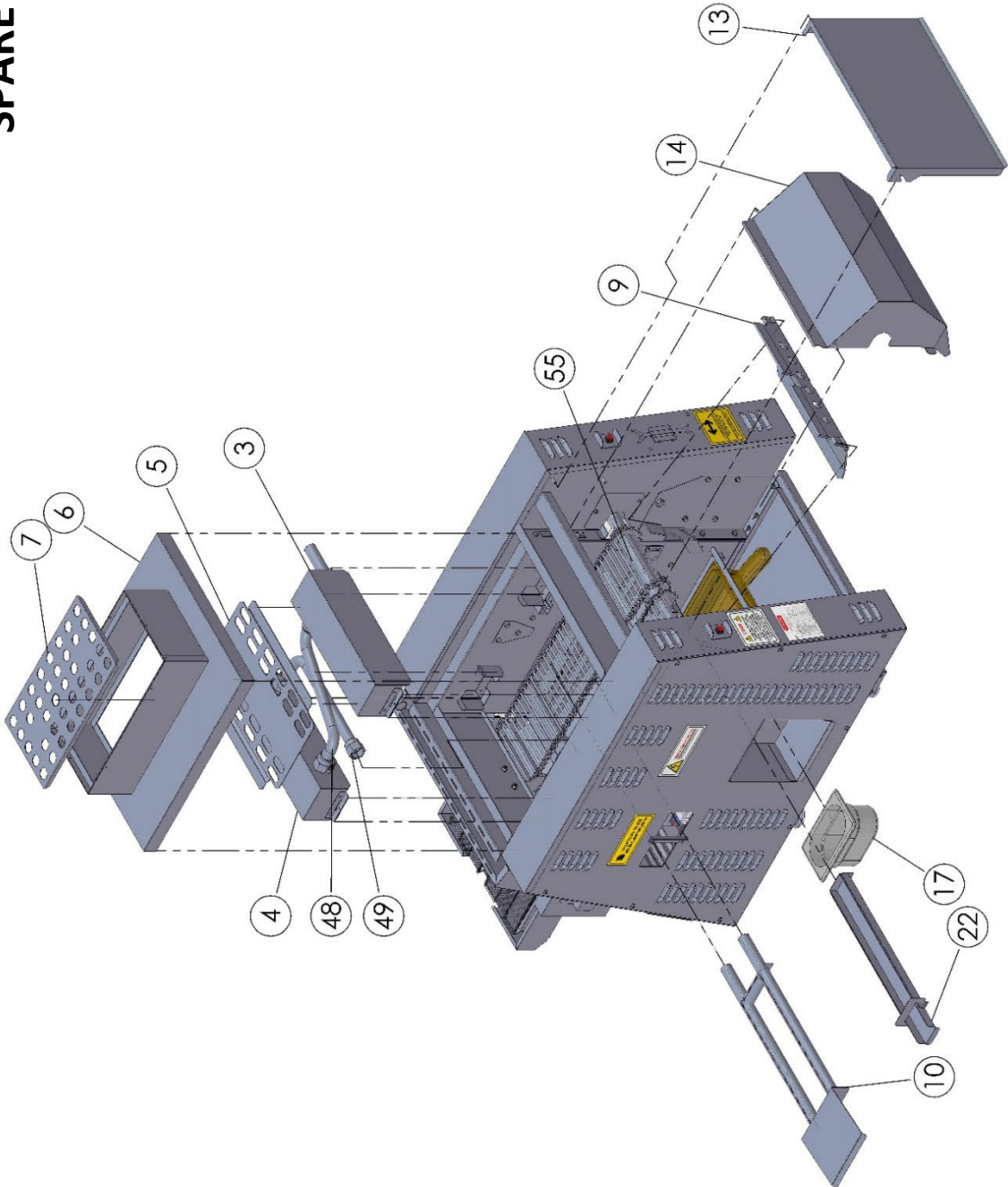

SPARE PART 3

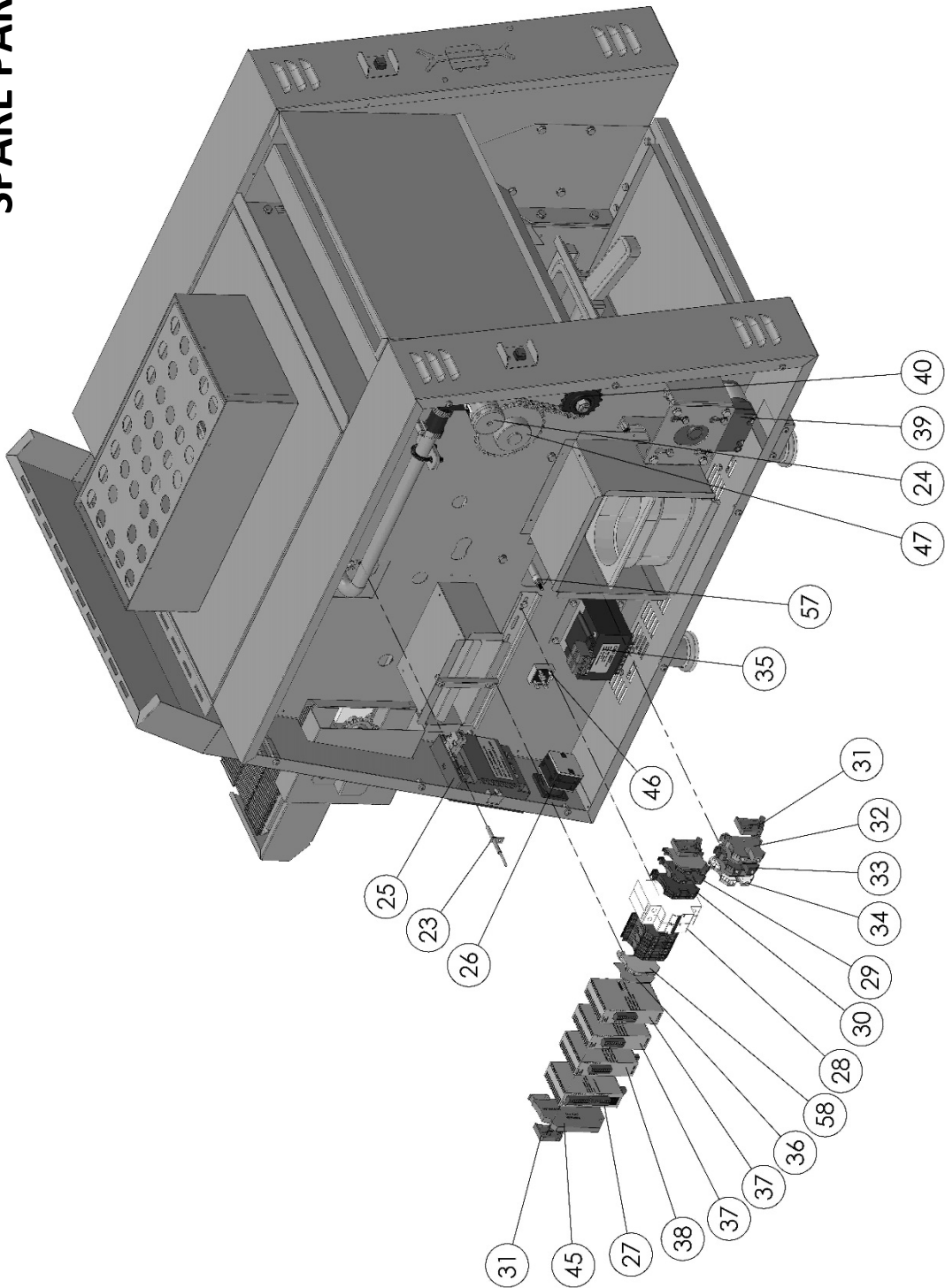

SPARE PART 4

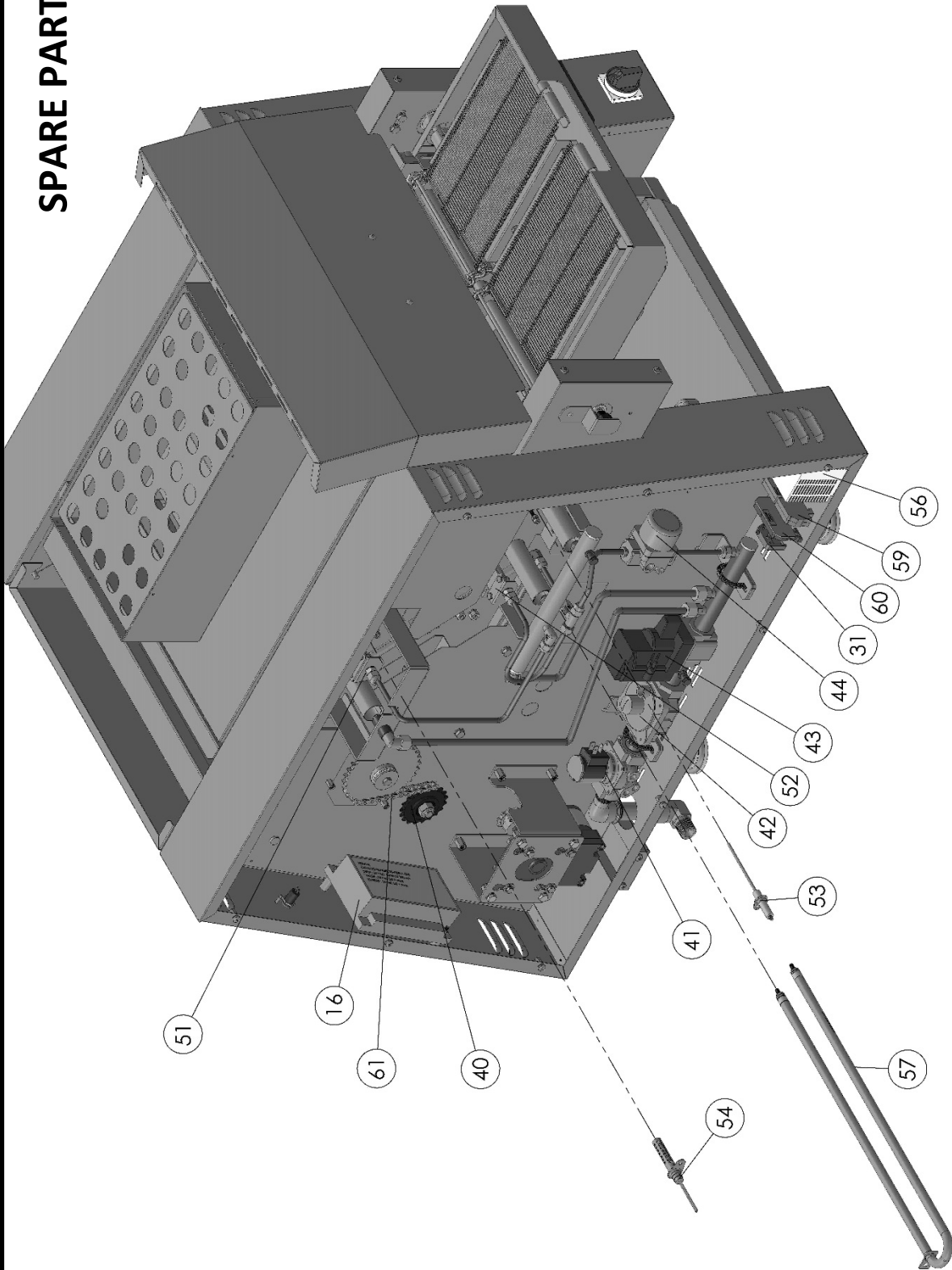

SEN 3000 SPARE PART LIST

NO	SPARE PART NUMBER	SPARE PART DEFINITION	PCS.	NO	SPARE PART NUMBER	SPARE PART DEFINITION	PCS.
1	00107M.	FEEDER BELT DRIVE BODY (RIGHT)	1	32	02211	CONNECTOR (BEIGE)	1
2	00107M	FEEDER BELT DRIVE BODY (LEFT)	1	33	02210	CONNECTOR (BLUE)	1
3	00114M	UPPER BURNER	1	34	02209	CONNECTOR	1
4	00115M	UPPER BURNER	1	35	03241	TRANSFORMER	1
5	03052	CHIMNEY VENTILATION PLATE	1	36	01384	CONNECTOR COVER	7
6	00113M	UPPER CHIMNEY	1	37	00153M	HEAT CARD	2
7	03051	CHIMNEY VENTILATION PLATE	1	38	00152M	HEAT CARD	1
8	03063	AMBER CAP FRAME PLATE	1	39	00134M	BELT ENGINE	2
9	03057	BELT STRIPPER PLATE	1	40	03126	CHAIN GEAR	2
10	00116M	LOWER BURNER	1	41	03147	GAS VALVE	1
11	03067	DIRT PAN PLATE	1	42	03153	REGULATOR	1
12	00123M	FEEDER BELT BODY PLATE	1	43	03151	MODULATION VALVE	1
13	03053	REAR COVER PLATE	1	44	03148	SOLENOID VALVE	1
14	00124M	PRODUCT ROTATION PLATE	1	45	03274	OPTIKAPTUR VALVE	1
15	03270	AMBER PAN	2	46	03414	DIODE	1
16	03152	IGNITION PROCESSOR	1	47	00140M	CHAIN GEAR	1
17	03260	GASTRONOM TRAY	1	48	03257	FANCOIL FLEX	1
18	00125M	INLET PROTECTION PLATE	1	49	03258	FANCOIL FLEX	1
19	00121M	RIGHT FEEDER BELT	1	50	00112M	BODY	1
20	00122M	LEFT FEEDER BELT	1	51	00130M	PILOT	1
21	03070	DIRT PAN	1	52	00131M	PILOT	1
22	00126M	GREASE TROUGH	1	53	03145-1	ELECTRODE	1
23	03170	THERMOCOUPLE	1	54	03146	IGNITION ELECTRODE	1
24	00148M	AIR ENGINE	1	55	00149M	BELT	1
25	01162M	LCD SCREEN	1	56	01284	POWER SUPPLY	1
26	02552	ON/OFF SWITCH	1	57	03169	RESISTANCE	1
27	01007M	PLC	1	58	00293	CONNECTOR (GROUNDING)	1
28	02189	FUSE	2	59	03243	CONNECTOR	2
29	00294	CONNECTOR (BLUE)	6	60	03244	CONNECTOR (GROUNDING)	1
30	00295	CONNECTOR	6	61	03245	CHAIN	1
31	00292	LIMITER	3				

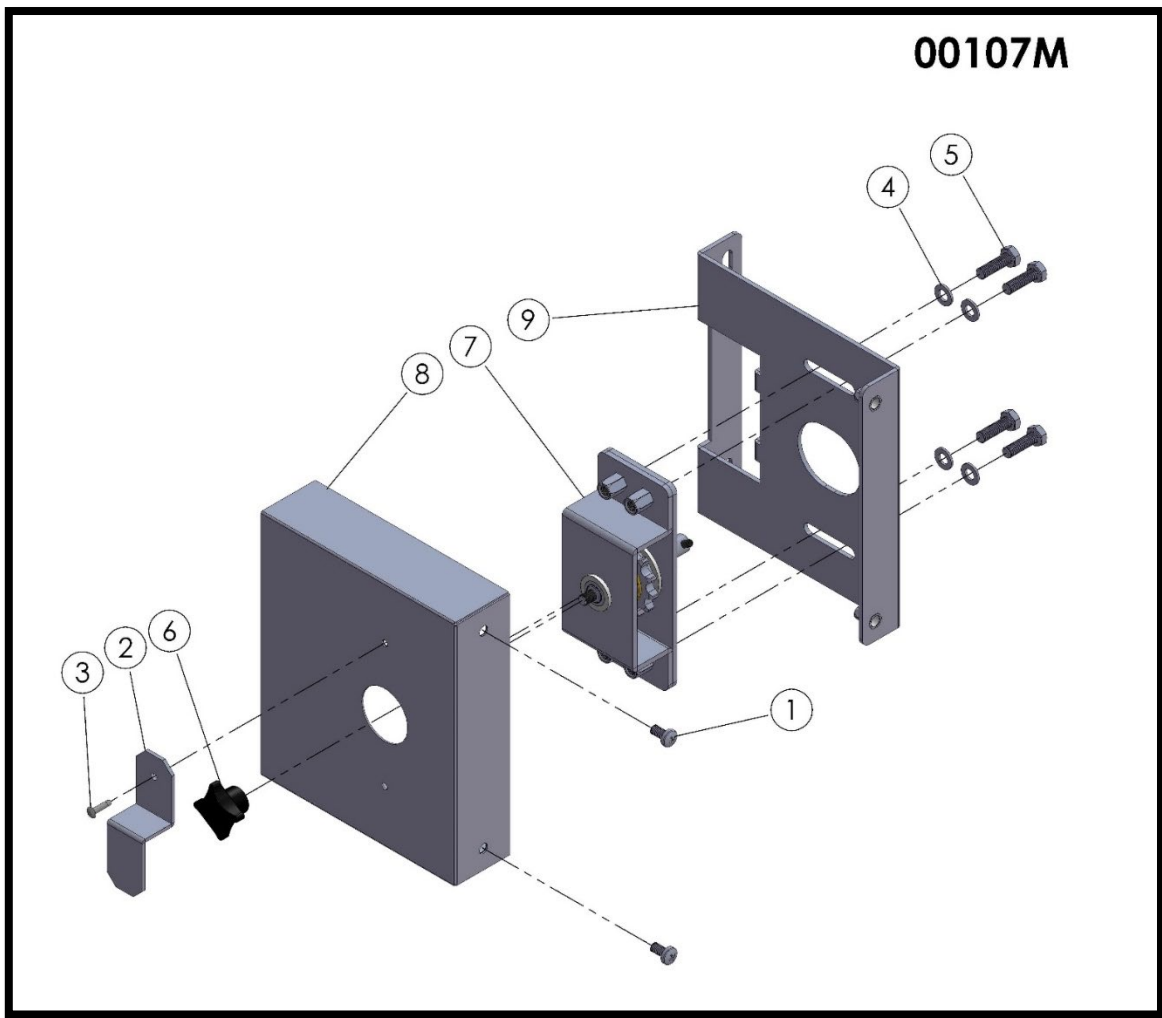

NO	SPARE PART NUMBER	SPARE PART DEFINITION	PCS.
1	00046	BOLT	2
2	03083	FEEDER BELT DRIVE LOCK PLATE	1
3	01568	RIVET	1
4	01817	WASHER	4
5	04079	BOLT	4
6	00124	BAKALITE	1
7	00105M	SMALL BELT GEAR	1
8	03082	FEEDER BELT DRIVE COVER PLATE	1
9	00106M	FEEDER BELT LATERAL BODY PLATE	1

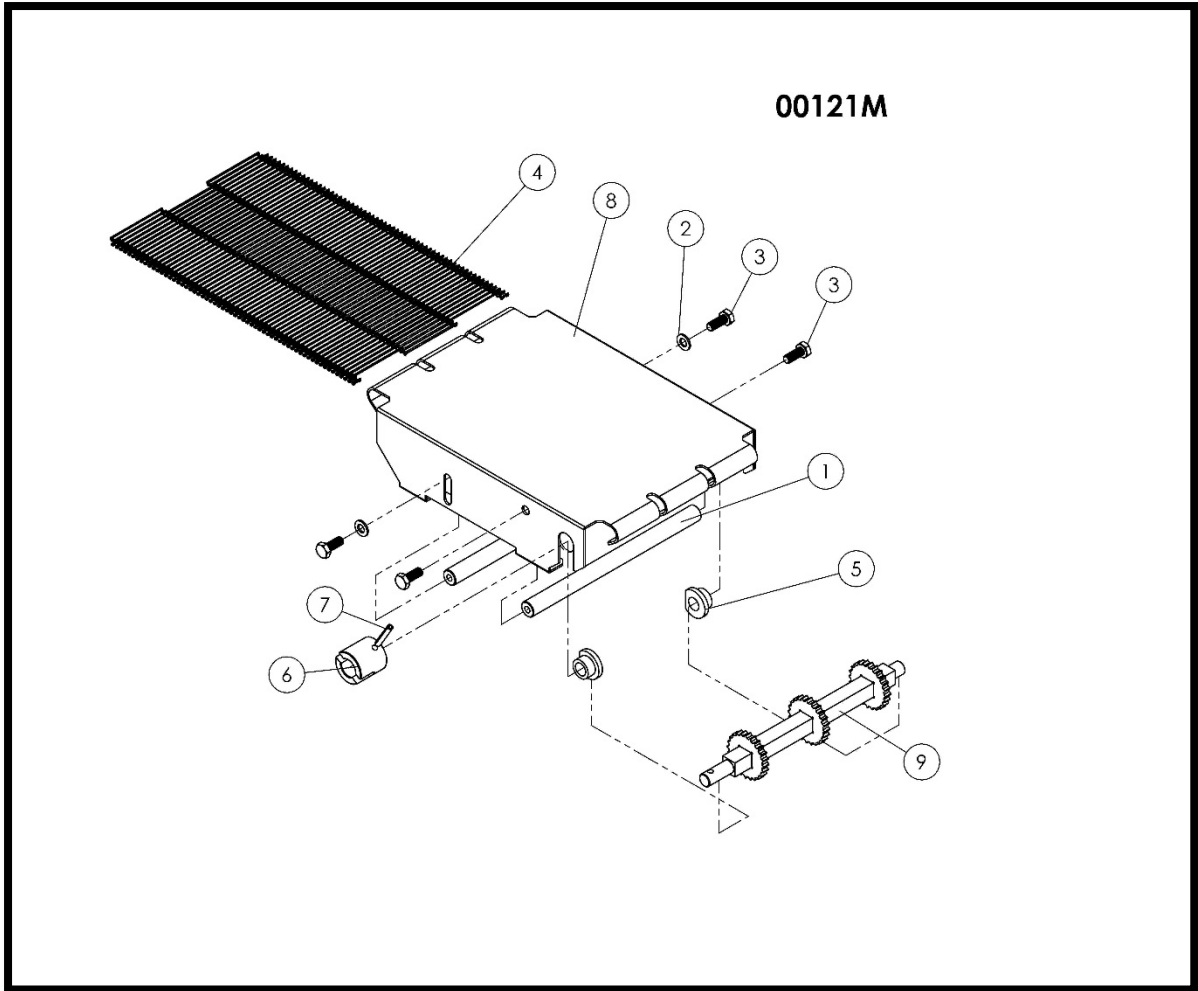

NO	SPARE PART NUMBER	SPARE PART DEFINITION	PCS.
1	03119	BELT SHAFT	2
2	00050	WASHER	2
3	03089	BOLT	4
4	00117M	SMALL BELT	1
5	03118	BEARING	2
6	03188	HUB	1
7	03223	PIN	1
8	00120M	SMALL BELT FRAME	1
9	00430M	CONVEYOR DRIVE SHAFT	1

PART 7: ELECTRICAL DIAGRAM

AUTOMATIC GRID

Customer : ŞENGÜN MAKİNA		SEN 3000	
Voltage:	220-230 Vac		
Frequency	50Hz		
Resistive Power:			
Motors power:	1,5 KW	Command voltage:	24 VAC-24 VDC
Power wires:	3X1,5 kw	Auxiliary circuits wires:	0.75 mm ²
Power circuits wires:	1.5 mm ²		

		28.09.2016		ŞENGÜN MAKİNA		ŞENGÜN MAKİNA				=	
		Live								+	
		Appr		SEN 3000							
Modification		Date		Name		Original		Replaced by		Page	
										1	
										7	

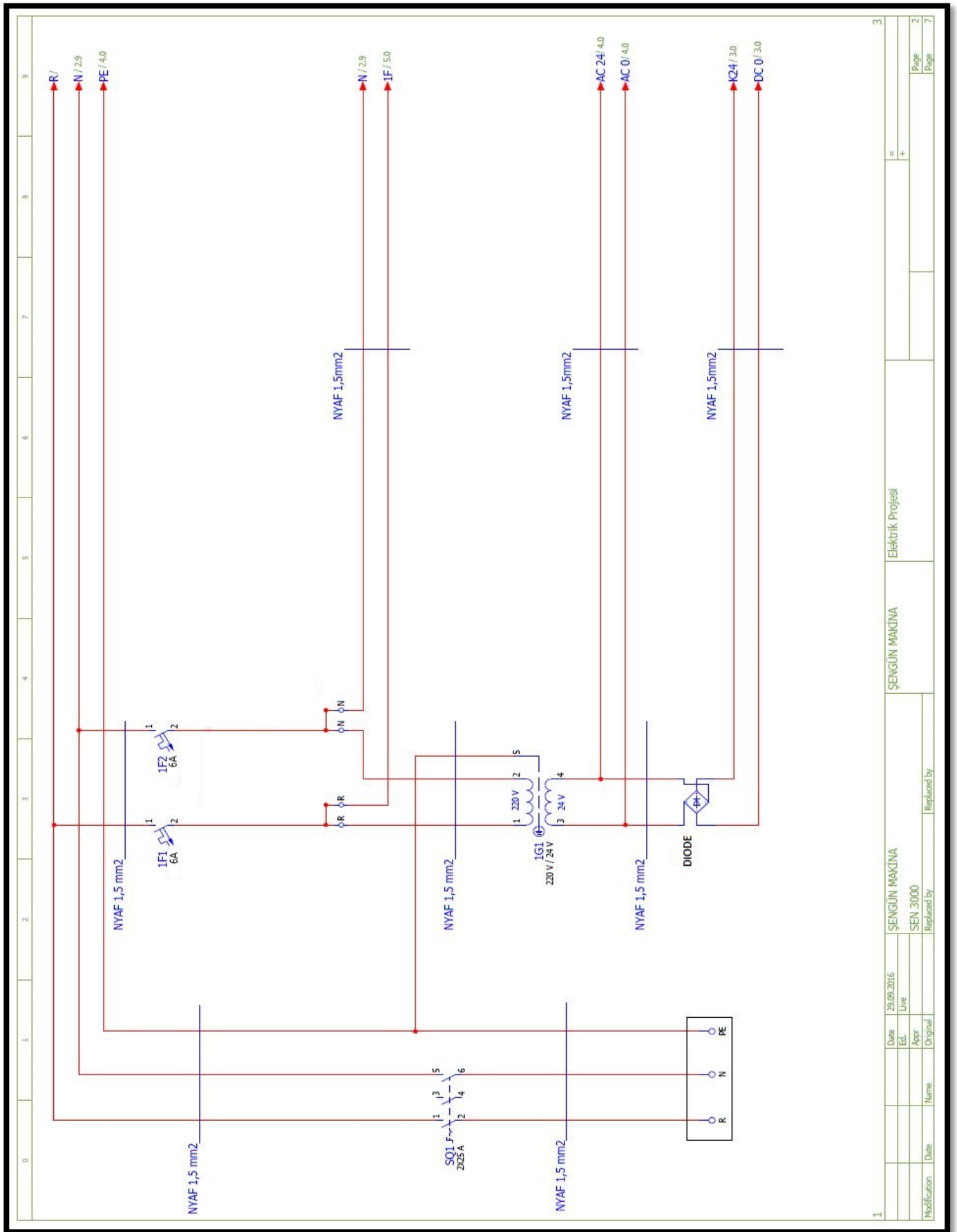

1	SENGÜN MAKİNA	SENGÜN MAKİNA	Elektrik Projesi	3
Date	25.09.2016	Ed.	+	
Appr.	SEN 3000	Replaced by		Page 2
Original		Replaced by		Page 7

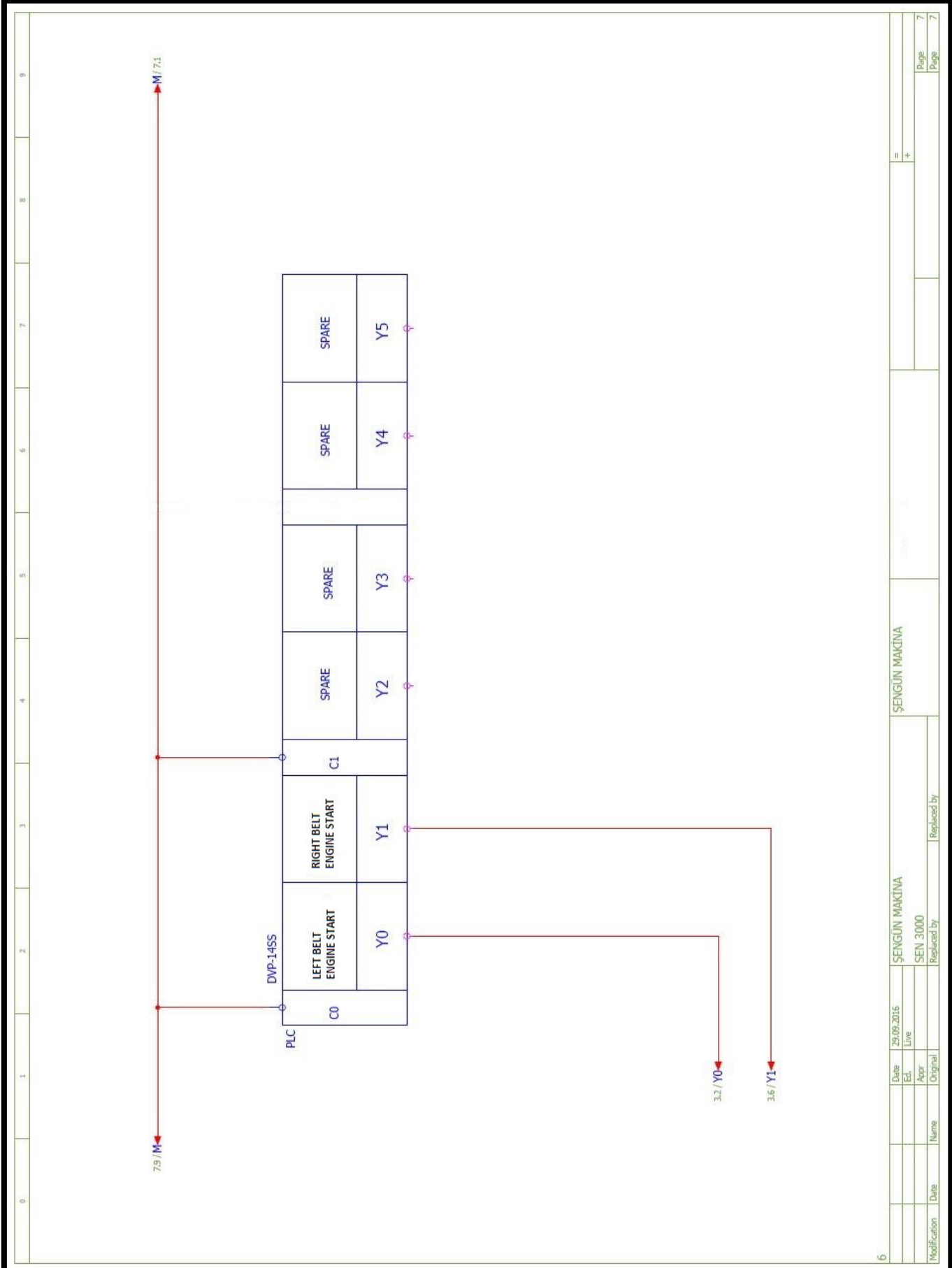

6

Date	29.09.2016	SEN GUN MAKINA	SEN GUN MAKINA	=	Page	7
Ed.	Live			+	Page	7
Appr		SEN 3000				
Original		Replaced by	Replaced by			

PART 8: TROUBLESHOOTING

8.1 “Temperature Limit Exceeded” Warning:

This warning indicates that 550 °C limit is exceeded. Broiler is stopped. The broiler is reset by turning off and on its switch after cooling.

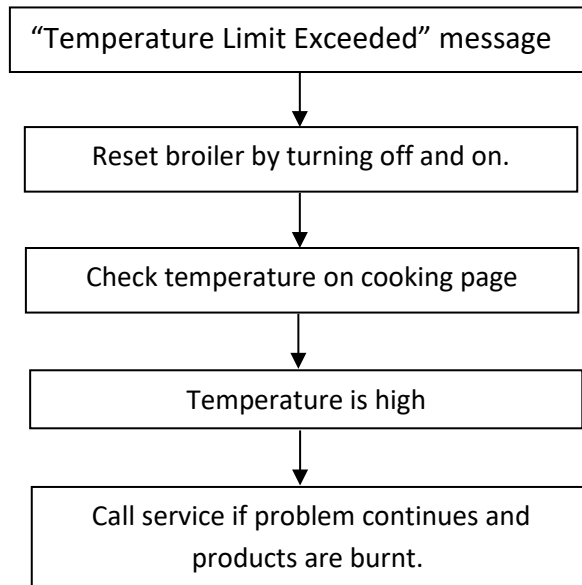

8.2 “Low Battery” Appears On The Screen:

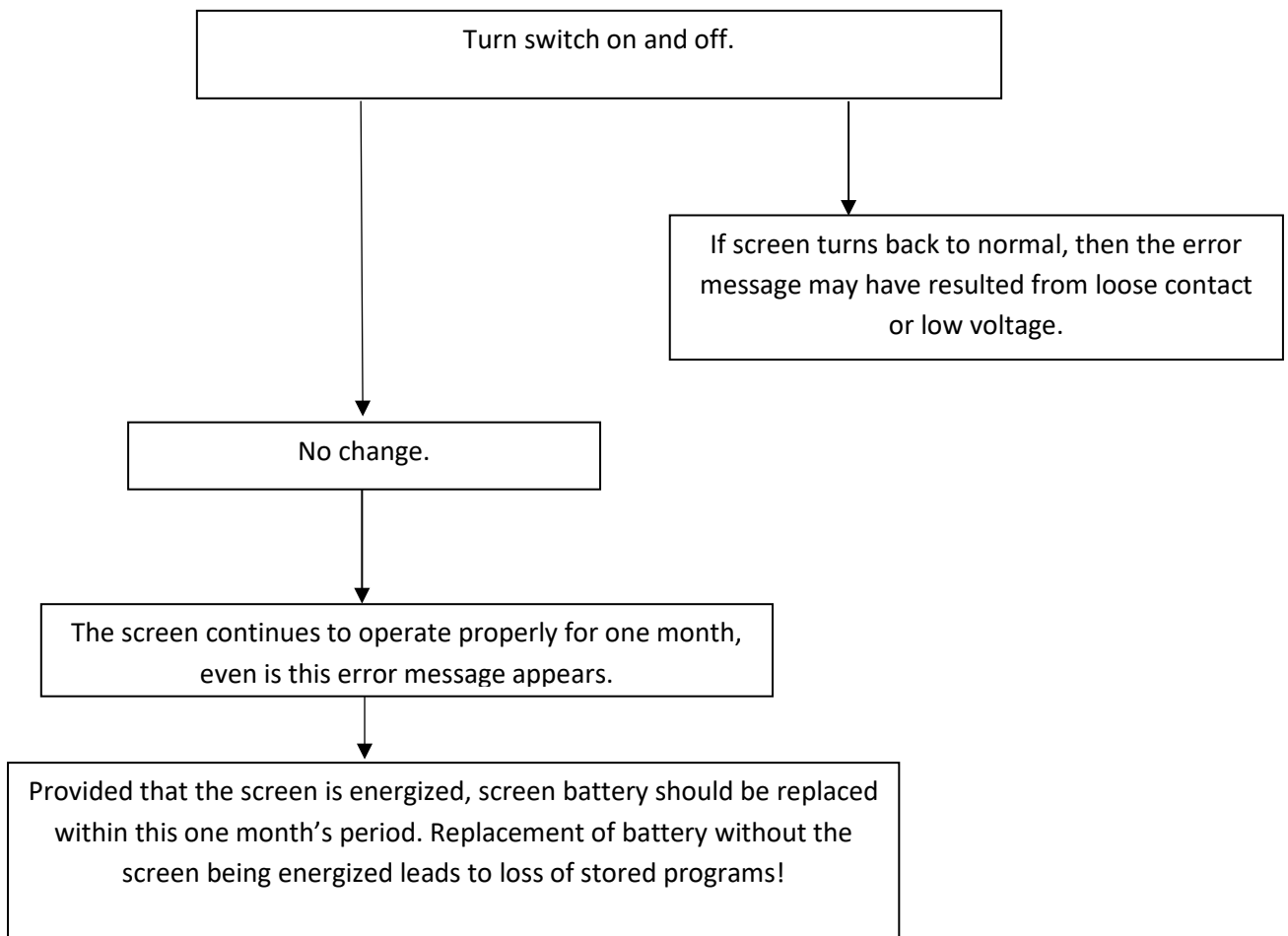

NOTE: Battery shall be supplied from electronics malls- service – manufacturer.

8.3 Temperature Reading Failure (Sensor Failure):

This message appears on the screen if no temperature data is transmitted from cooking chamber to the control unit.

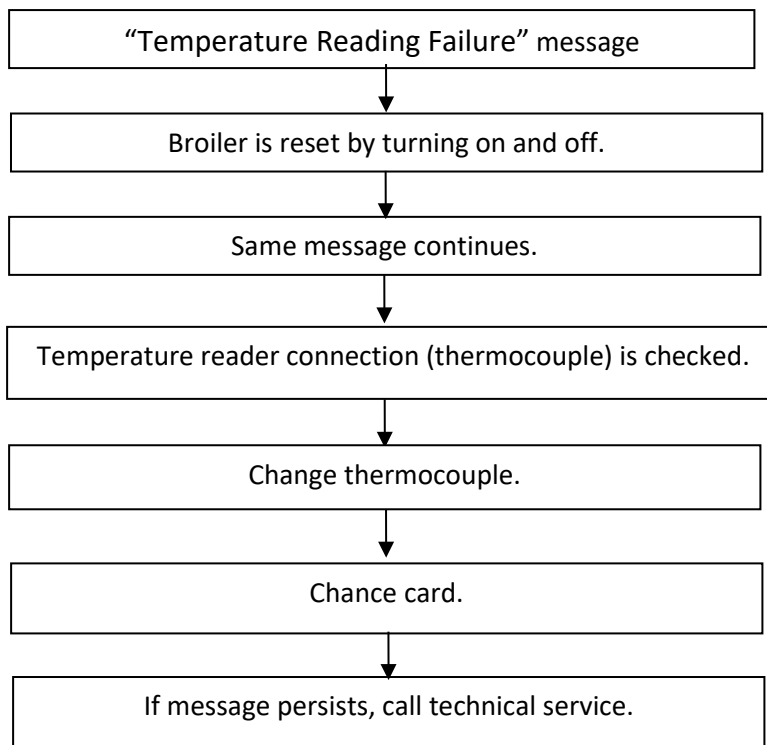

8.4 Ignition Failure:

This warning appears when broiler is not ignited, or a failure occurs in burner system.

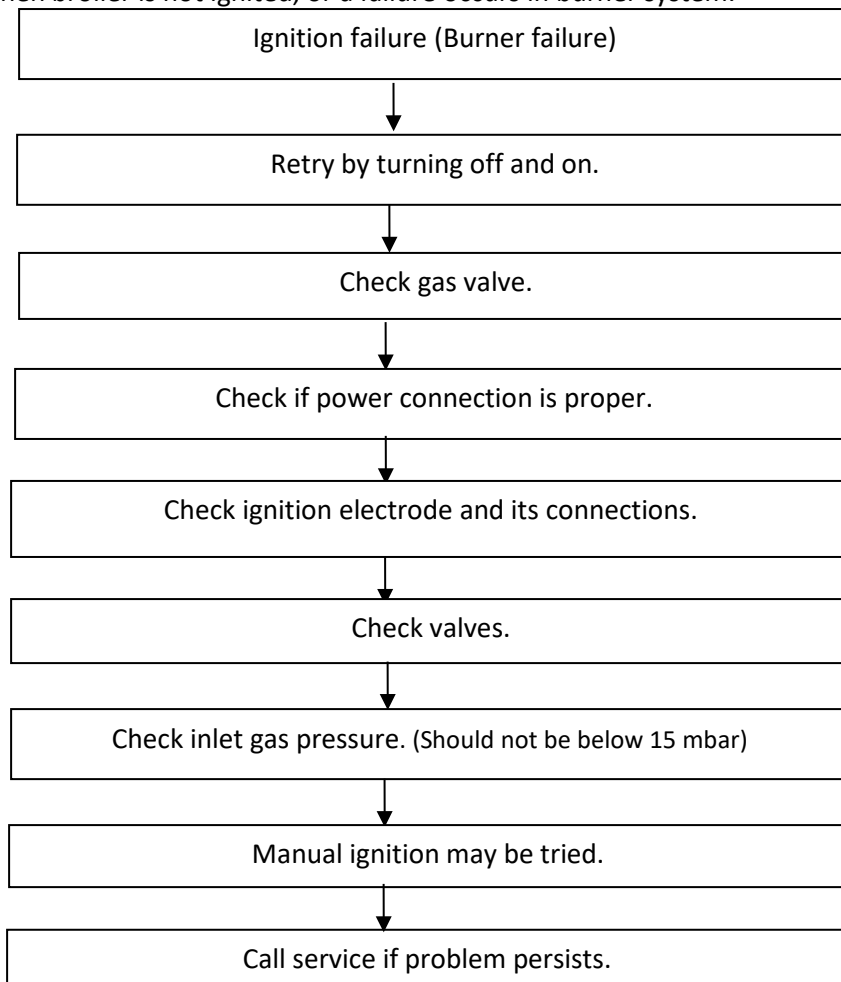

8.5 Products Are Not Cooking:

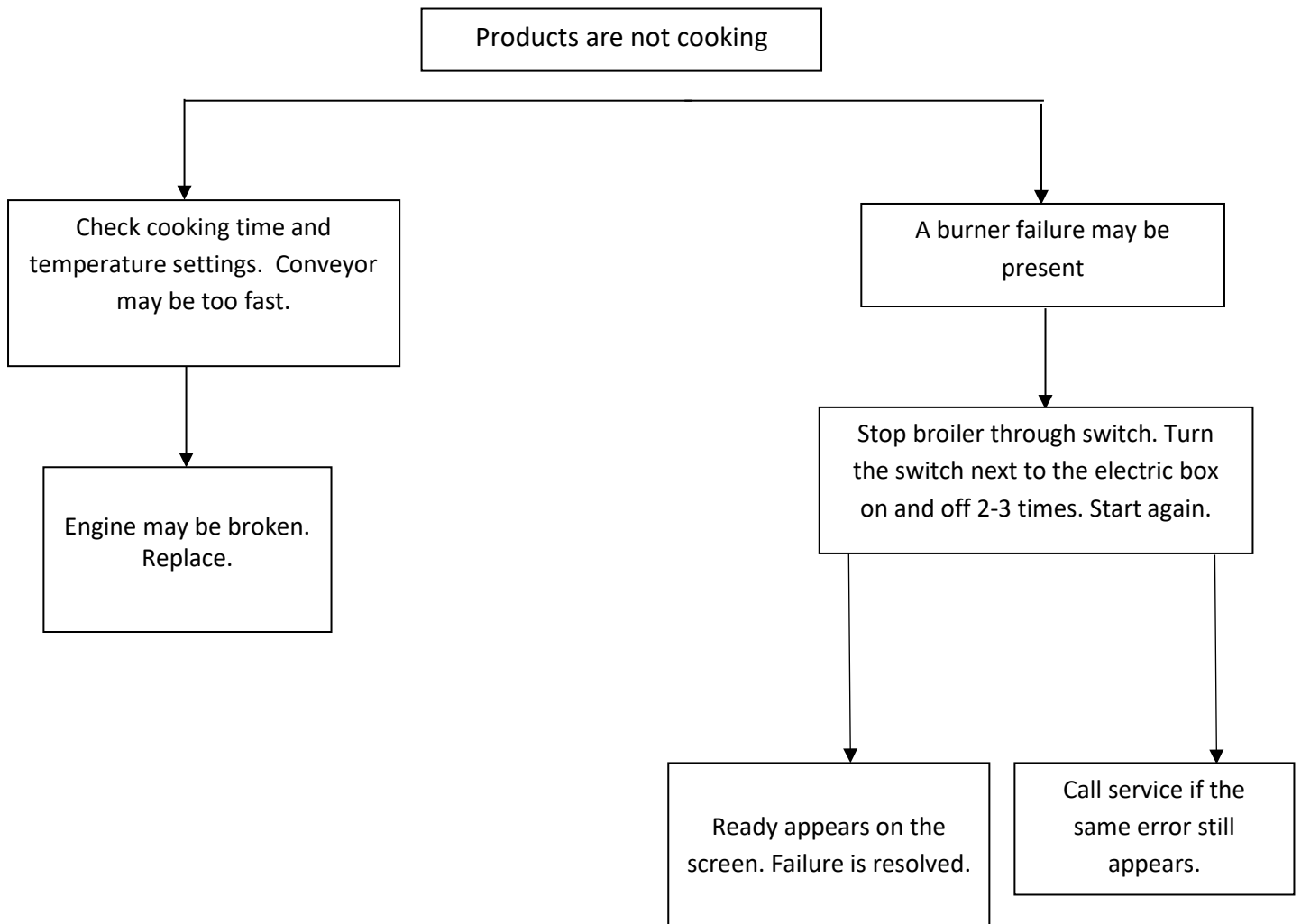

8.6 How to Call Technical Service:

If broiler does not operate or ceases to operate, check if automatic fuses are functioning. If there's no problem there, you can now call "Authorized Technical Service". Technical service call number is given on the nameplate behind the broiler. If you cannot see technical service call number on the broiler, call the manufacturer company to be informed about the nearest technical service.

PART 9: LABELS

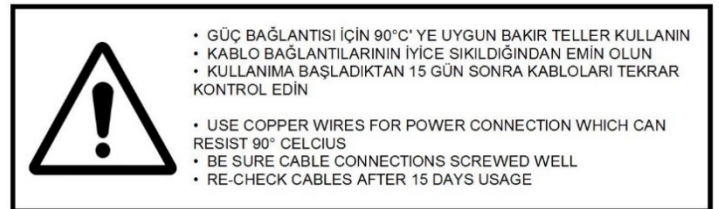
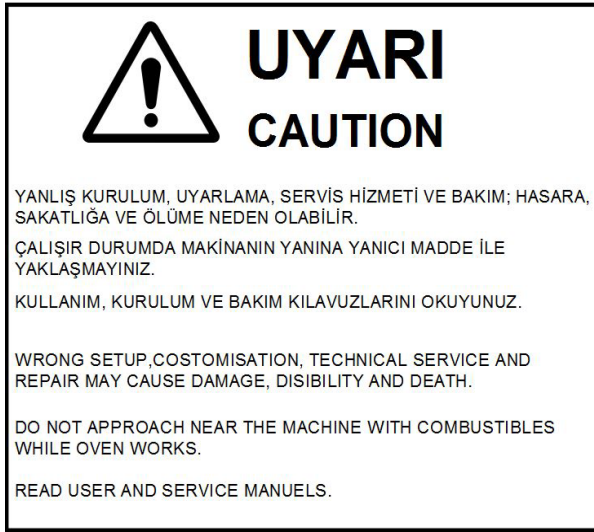

This device must be installed in accordance with regulations. Refer to the instructions before installing and using the device.

Manufacturer: Şengün Makina İnş. Kirt. San. Tic. Ltd. Şti.

İkitelli Organize Sanayi Bölgesi Mah. Atatürk Bulvarı Pufa İş Merkezi No:98 Bodrum Kat:2-

Başakşehir – İstanbul / TURKEY

Tel: +90 212 671 23 23 Pbx.

Fax: +90 671 88 28

www.acpisir.com

www.sengunmakina.com

www.senoven.com

info@sengunmakina.com