

Flatbread Toaster

Model GST-1H Owner's Manual

Manufacturing Numbers:
9210972

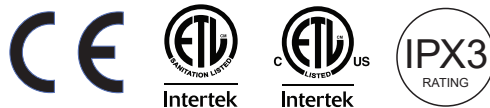

TABLE OF CONTENTS

Warranty Information 2
Service/Technical Assistance..... 2
Important Safety Information 3
Warnings 3
Specifications 4
 Dimensions 4
 Electrical & Plug Specifications..... 4
 Shipping Weight 4
Installation..... 5
Operation..... 5
 Light/Dark Adjustments 5
User Mode 6
Manager Mode 6
Safety Features..... 6
 Hi-Limit Control 6
 Fault Messages..... 6
 Purging product from Toaster 6
Daily Cleaning..... 7
 Inspect the belts 7
 Replacing Belts 7
Troubleshooting 10
Replacement Parts 12
Exploded Diagram #1 13
Exploded Diagram #2 14
Exploded Diagram #3 15
Exploded Diagram #4 16
Exploded Diagram #5 17
Wiring Diagram 18
Notes..... 19
Limited Warranty 20

Warranty Information

Please read the full text of the Limited Warranty in this manual.

If the unit arrives damaged, contact the carrier immediately and file a damage claim with them. Save all packing materials when filing a claim. Freight damage claims are the responsibility of the purchaser and are not covered under warranty.

The warranty does not extend to:

- Damages caused in shipment or damage as result of improper use.
- Installation of electrical service.
- Normal maintenance as outlined in this manual.
- Malfunction resulting from improper maintenance.
- Damage caused by abuse or careless handling.
- Damage from moisture into electrical components.
- Damage from tampering with, removal of, or changing any preset control or safety device.

Service/Technical Assistance

If you experience any problems with the installation or operation of your unit, contact Antunes Technical Service at +1-877-392-7854 (toll free).

Fill in the information below and have it handy when calling for assistance. The serial number is on the specification plate attached to the unit.

Purchased From

Date of Purchase

Model Number

Serial Number

Manufacturing Number

Use only genuine Antunes replacement parts in this unit. Use of replacement parts other than those supplied by the manufacturer will void the warranty.

IMPORTANT

Antunes reserves the right to change specifications and product design without notice. Such revisions do not entitle the buyer to corresponding changes, improvements, additions or replacements for previously purchased equipment.

IMPORTANT

Keep these instructions for future reference. If the unit changes ownership, be sure this manual accompanies the equipment.

Important Safety Information

Use the following guidelines for safe operation of the unit.

- Read all instructions before using equipment.
- For your safety, the equipment is furnished with a properly grounded cord connector. Do not attempt to defeat the grounded connector.
- Install or locate the equipment only for its intended use as described in this manual. Do not use corrosive chemicals in this equipment.
- Do not operate this equipment if it has a damaged cord or plug, if it is not working properly, or if it has been damaged or dropped.
- This equipment should be serviced by qualified personnel only. Contact Antunes Technical Service for adjustment or repair.
- Do not block or cover any openings on the unit.
- Do not immerse cord or plug in water.
- Keep cord away from heated surfaces.
- Do not allow cord to hang over edge of table or counter.
- Turn the power off, unplug the power cord, and allow unit to cool down before performing any service or maintenance on the unit.
- This appliance can be used by children aged from 8 years and above and persons with reduced physical, sensory or mental capabilities or lack of experience and knowledge if they have been given supervision or instruction concerning use of the appliance in a safe way and understand the hazards involved.
- Children shall not play with the appliance.
- Cleaning and user maintenance shall not be made by children without supervision.
- **Turning off the power switch does NOT turn off all power to the unit.**

- The equipment should be grounded according to local electrical codes to prevent the possibility of electrical shock. It requires a grounded receptacle with separate electrical lines, protected by fuses or circuit breaker of the proper rating.
- All electrical connections must be in accordance with local electrical codes and any other applicable codes.
- Do not clean this appliance with a water jet.

Warnings

Be advised of the following warnings when operating and performing maintenance on this unit.

- If the supply cord is damaged, it must be replaced by the manufacturer or its service agent or a similarly qualified person in order to avoid a hazard.
 - Do not modify the power supply cord plug. If it does not fit the outlet, have a proper outlet installed by a qualified electrician.
 - Do not use an extension cord with this appliance.
 - Electrical ground is required on this appliance.
 - Check with a qualified electrician if you are in doubt as to whether the appliance is properly grounded.
 - When using a chemical cleaner, be sure it is safe to use on cast aluminum. Observe all precautions and warnings on product label.
 - Inspection, testing, and repair of electrical equipment should only be performed by qualified service personnel.
 - Do not use a sanitizing solution or abrasive materials. These may cause damage to the stainless steel finish.
 - Chlorides or phosphates in cleaning agents (e.g. bleach, sanitizers, degreasers or detergents) could cause permanent damage to stainless steel equipment. The damage is usually in the form of discoloration, dulling of metal surface finish, pits, voids, holes, or cracks. This damage is permanent and not covered by warranty.
- The following tips will help in the maintenance of stainless steel equipment:
 - Always use soft, damp cloth for cleaning, rinse with clear water and wipe dry. When required, always rub in direction of metal polish lines.
 - Routine cleaning should be done daily with soap, ammonia detergent, and water.
 - Stains and spots should be sponged using a vinegar solution.
 - Finger marks and smears should be rubbed off using soap and water.
 - Hard water spots should be removed using a vinegar solution.

Specifications

Dimensions

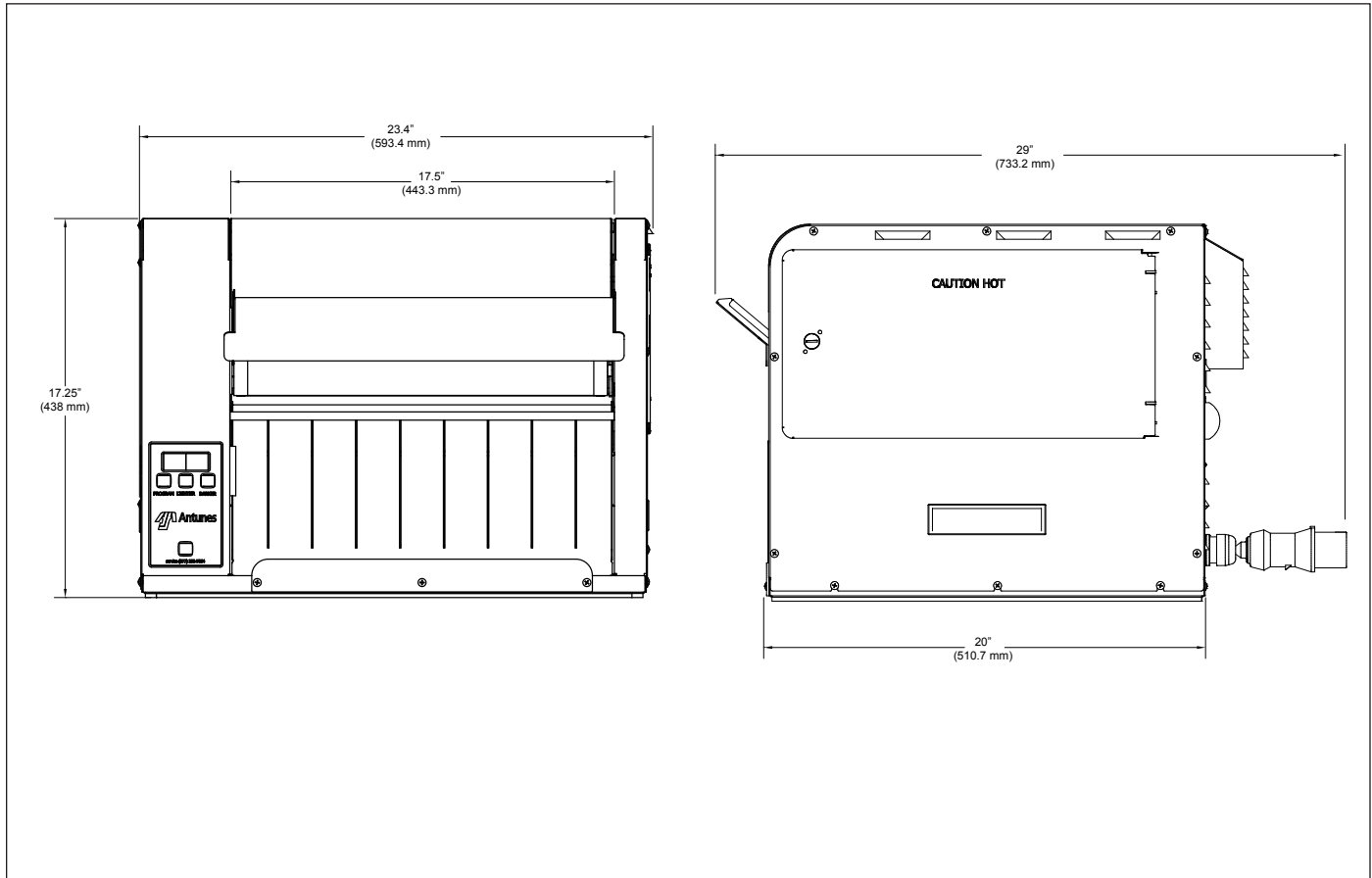

Electrical & Plug Specifications

Model & Mfg. No.	Volts	Watts	Hertz	Plug Description
GST-1H 9210972	230	4600	50	IEC-309 Pin & Sleeve, 32 Amp., 230 Volt

Shipping Weight

GST-1H 150 lbs (68 kg)

Installation

1. Remove unit and all packing materials from shipping carton.
2. Open the Accessories Box. It should contain the following:
 - a. Chute
 - b. Feeder
 - c. Owner's Manual

NOTE: If any parts are missing or damaged, contact Antunes Customer Service IMMEDIATELY at +1-877-392-7856 (toll free).

3. Remove all packing materials and protective coverings from the unit and accessories.
4. With assistance, place the unit in the proper location.
5. Remove the top cover. Wipe the top cover, chute, and feeder with a clean sanitizer soaked towel. Allow to air dry.
6. Wipe the entire exterior of the unit with a clean damp towel. Allow to air dry.
7. Attach the top cover, feeder and chute (Figure 3).
8. Unlock and open the side panel according to figure 2. Cut and remove the wire ties indicated in

IMPORTANT

Do NOT plug in the power cord or turn the unit on before removing the wire ties indicated in the following step. Damage to the unit may result.

Figure 2.

When placing the toaster into service, pay attention to the following guidelines.

- Make sure the unit is off and the unit is at room temperature before plugging in the power cord.
- Do not block or cover any openings on the unit.
- Do not immerse the power cord or plug in water.
- Keep the power cord away from heated surfaces.
- Do not allow the power cord to hang over edge of table or counter.
- Place the unit on a sturdy, level table or other work surface.
- Turn the unit off if it is on.
- Ensure the line voltage corresponds to the stated voltage on the specification label and power cord warning tag.

9. Plug the power cord into the appropriate power outlet. Refer to the specification plate for the proper voltage.

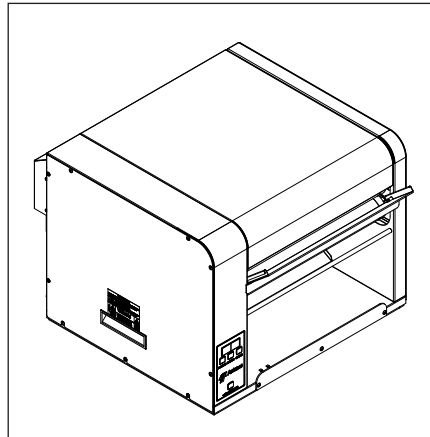

Figure 1. Flatbread Toaster (GST-1H)

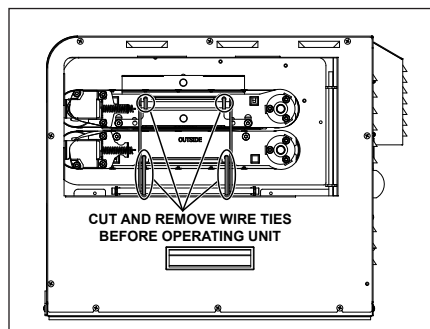

Figure 2. Remove Wire Ties

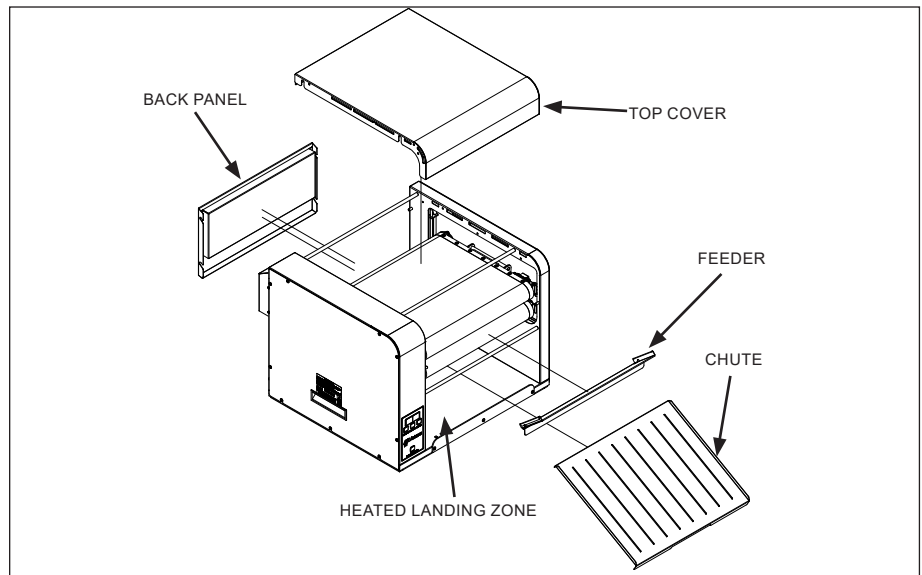

Figure 3. Components

Operation

1. Press and release the Power button to turn the toaster on. Allow the toaster to warm up until **USE** appears in the display
2. Insert product into the unit using the feeder.
3. Finished product drops onto the heated landing zone.

Light/Dark Adjustments

The light/dark value can be adjusted when the unit is displaying "USE". To adjust the light/dark value, press the **LIGHTER** or **DARKER** button. The display will change to show the current light/dark value.

NOTE: The default light/dark value is d0.

Press the **LIGHTER** or **DARKER** buttons to change the light/dark value. The adjustment range is L1-L9 and d0-d9. L9 is the lightest, d0 is the middle, and d9 is the darkest setting.

To save the light/dark value, wait 5 seconds until the screen displays "USE".

NOTE: Adjusting the light/dark value does NOT change the temperature. It changes the speed of the conveyors. The light/dark value will reset to the default value of d0 when the unit is turned off.

User Mode

User Mode allows an operator to view the toaster settings but does not permit any adjustments.

1. Press and hold the **PROGRAM** button for 5 seconds. After 5 seconds, the display will show the actual temperature of the top Platen.
2. Press the **LIGHTER** button to toggle between the Setpoint and actual temperature of the top Platen Heater.
3. Press the **PROGRAM** button for 5 seconds. After 5 seconds, the display will show the actual temperature of the bottom Platen.
4. Press the **LIGHTER** button to toggle between the Setpoint and actual temperature of the bottom Platen Heater.
5. Press the **PROGRAM** button to proceed to the Motor Menu. The display shows actual speed of the motor.
6. Press the **LIGHTER** button to toggle between the Setpoint and actual speed of the Motor.

NOTE: The unit will exit User Mode after 5 seconds of keypad inactivity.

Manager Mode

Manager Mode allows an operator to view and adjust the following settings:

- Heater Temperature (front/rear)
- Motor Speed
- Temperature Units (Celsius or Fahrenheit)

Manager Mode also allows an operator to view (but not adjust) the Ambient Temperature of the Control Compartment.

1. Press and release the Power button to turn the toaster off.
2. Press and release the Power button while holding the **PROGRAM** button. Continue holding the button until “ENA” appears on the display (after approximately 10 seconds).
3. Release the **PROGRAM** button. The display shows the Heater Setpoint Temperature.
4. To adjust the Heater Setpoint Temperature, press the **LIGHTER** or **DARKER** buttons to reach the desired temperature.

NOTE: The supplied temperature setting for the Platen is 580°F (304°C). It may be set from 500°F (260°C) to 600 F (316°C)

5. Press the **PROGRAM** button to program the motor speed.
6. Adjust the Motor Speed Setpoint by pressing the **LIGHTER** or **DARKER** buttons to change the motor speed.

NOTE: The Motor Speed is adjustable from 10-100. The supplied setting for Mfg. No. 9210972 is 98.

7. Press the **PROGRAM** button to proceed to the Temperature Units.
8. To change the Temperatures units from Fahrenheit or Celsius, press the **LIGHTER** or **DARKER** buttons.
9. Press and hold the **PROGRAM** button to save any changes.

NOTE: The unit exits Manager Mode after 30 seconds of keypad inactivity.

Safety Features

Hi-Limit Control

A Hi-Limit Control turns off electrical power to the heaters and control circuits and displays HL if the unit overheats. To reset the control:

1. Let the unit cool for 15 minutes.
2. Locate the Hi-Limit Controls on the rear of the unit. Remove the black protective cap.
3. Press and release the button. Re-install the protective cap.

NOTE: If the Hi-Limit Control requires continuous resetting, contact Antunes Technical Service.

Purging product from Toaster

If product gets stuck in the toaster, press and hold both the **UP** and **DOWN** arrow buttons to increase the belt speed until the product is purged from the toaster.

Fault Messages

The unit displays fault messages when there is a problem with the unit.

“**Hi**” flashes if the Platen Heater temperature is 30°F more than the Setpoint or if the Platen Thermocouple is disconnected or open.

“**CHEC**” flashes when the control compartment ambient temperature is more than 150°F (66°C). All heaters shut off. The unit will not restart until the control compartment ambient temperature falls below 140°F (60°C).

“**PO**” flashes if the incoming power drops below 190 volts. The toaster shuts down.

“**StoP**” flashes when the motor has stopped for seven continuous seconds.

“**SpEd**” flashes when the motor speed drops 25% below the Setpoint for 30 continuous seconds.

“**HL**” The Hi-Limit has tripped and needs to be reset.

Error Codes

If any of the following Error Codes appear, turn the toaster off. Allow the unit to cool. Then turn the toaster on. If the error repeats, contact Antunes Technical Service for assistance.

NOTE: For ERR #1 though 3, 4 through 7, and any number above 30, Cycle the power. If error persists, the control board must be replaced.

Error #	Description
4	Dip Switch settings for S6 on control board not set correctly. Correct settings are: 1-1-0-1 for Mfg. No. 9210972. If set correctly and error persists, replace control board.
8	Motor running when it should be off (check tachometer wiring).
Chec	Internal temperature over 158°F.
11 & 12	Top Thermocouple.
13 & 14	Top heater or SSR issues.
15 & 16	Bottom Thermocouple.
17 & 18	Bottom heater or SSR issues.
StoP	Motor is stopped. Check drive system.
t-HL	Top Hi-Limit Thermostat tripped.
b-HL	Bottom Hi-Limit Thermostat tripped.

Daily Cleaning

IMPORTANT

DO NOT INSERT HANDS BETWEEN THE BELTS. USE CARE WHEN CLEANING THE BELTS AS THEY ARE MOVING. PERSONAL INJURY MAY RESULT!

NOTE: The following supplies and cleansers are required for cleaning and have been validated by Antunes to be the most effective. The use of alternative supplies and chemicals may not effectively clean the belts and could cause belt damage.

- Heat Resistant Gloves
 - Clean Towels
 - Water
 - Sanitizer bucket
1. Press and release the Power button to turn the unit off. The unit enters a 45 minutes cool-down mode and automatically shuts down when complete.

NOTE: Be sure to perform cleaning steps during cool-down mode.

NOTE: The conveyors continue to turn during the cool-down mode.

2. Put on heat resistant gloves. Remove the Top Cover, Feeder, and Chute (Figure 3).
3. Wash, rinse and sanitize the Top Cover, Feeder, and Chute at the 3-compartment sink.

Inspect the belts

NOTE: Replace any belts that are torn, folded, missing snaps, or damaged. Belts should be removed ONLY during belt replacement or when required in a service situation (see images on page 9 for examples). Refer to the section titled Replacing Belts for instructions on removing and installing belts.

4. Clean the top and bottom belts with a clean, sanitized towel.
5. Wipe the exterior surfaces of the unit with a clean, sanitizer-soaked towel and allow to air dry.
6. Reinstall all accessories (Figure 3).
7. Turn the unit on and test the unit before returning it to operation.

Replacing Belts

NOTE: Be sure to clean and sanitize the Belts completely. Failure to properly clean the Belts will shorten the life of the Belts and result in poor performance.

Over time, the Belts begin to show signs of wear. This wear appears in the form of tears, folds, or other damage of the belt, at which point all belts should be replaced.

Removing Belts

1. Press and release the Power button to turn the unit off. The Tortilla Warmer enters a cool-down mode. Wait until the unit automatically shuts down and OFF appears on the display.
2. Unplug the power cord.
3. Wearing heat resistant gloves, remove the Top Cover, Feeder, and Chute and set aside (Figure 3).
4. Facing the front of the unit, move to the right side panel. Rotate the unit as necessary for access.
5. Unlock the side panel door using a screwdriver, coin, or similar tool. Open the side panel (Figure 4).
6. Unlock the Lock Lever (Figure 4).
7. Remove tension on the Top Belt by pushing the Top FRONT Roller IN and UP until it locks into position.
8. Remove tension on the Bottom Belt by pushing the Bottom FRONT Roller IN and DOWN.
9. Rotate the pins shown in Figure 5.
10. Lift up on the two brackets shown in Figure 5.

NOTE: If the brackets will not move, rotate the pins from Step 9 until the brackets can be lifted up.

11. Slide the Belts out of the unit and discard (Figure 6).
12. With belts removed, wipe all four rollers and the top and bottom heater cover plates with a clean sanitized towel to remove any debris (Figure 6).

NOTE: Any debris stuck on the roller/cover plates can damage the belts.

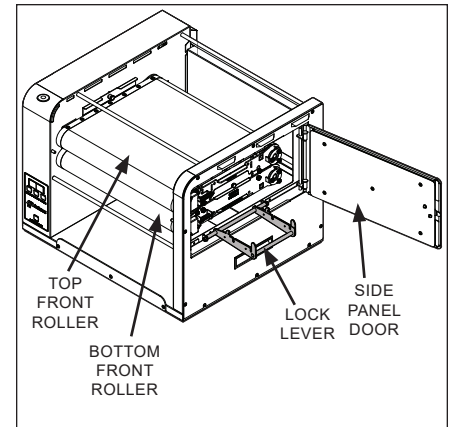

Figure 4. Open side panel

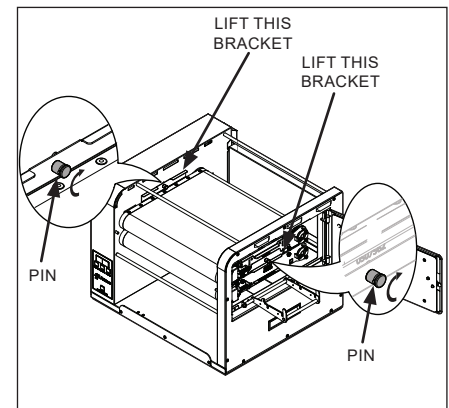

Figure 5. Rotate Pins and Lift Brackets

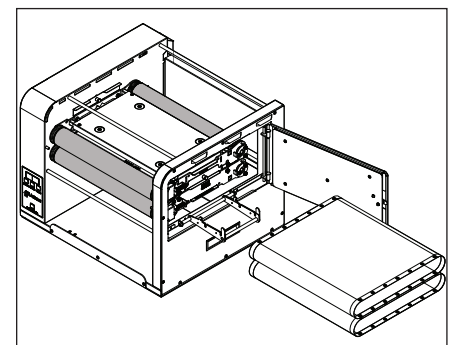

Figure 6. Remove Belts

Installing Belts

1. Follow the steps for Removing Belts.
2. Wipe both sides of the new Belts with a clean, sanitized towel sprayed with an approved sanitizer and allow to air dry.
3. Slide the new bottom belt over the bottom rollers (Figure 6).
4. Slide the new top belt over the top rollers (Figure 6).

NOTE: You may need to lift the upper roller assembly when installing the belts.

NOTE: Make sure the snaps are aligned evenly on the rollers. The snaps on the belts should face inside and should be aligned with the grooves on the roller. Belts must be installed so the exposed diagonal seam of the belt is away from the direction of belt travel.

5. Restore tension on the bottom belt by pushing UP and OUT (Figure 4).
6. Restore the tension on the top belt by pushing DOWN and OUT (Figure 4).
7. Lock the brackets shown in Figure 7 by rotating the highlighted pin so the brackets drop down into place. Push down on each bracket to ensure they are in position.
8. Engage the lock lever as shown in Figure 11. Make sure the lock lever is properly inserted into the slotted grooves.
9. Close and lock the side panel (Figure 8).
10. Reinstall the accessories (Figure 3).
11. Plug the power cord into the appropriate outlet, turn the unit on. Return the unit to use.

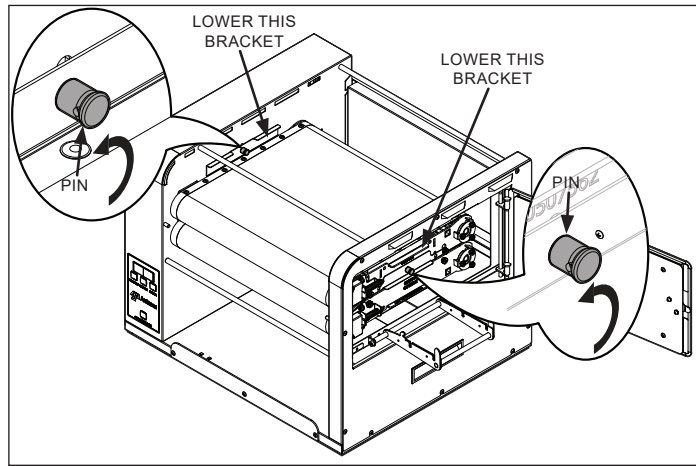

Figure 7. Lock the Brackets

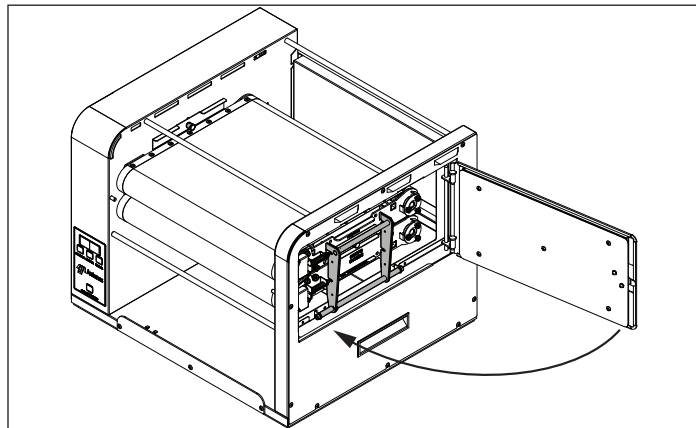
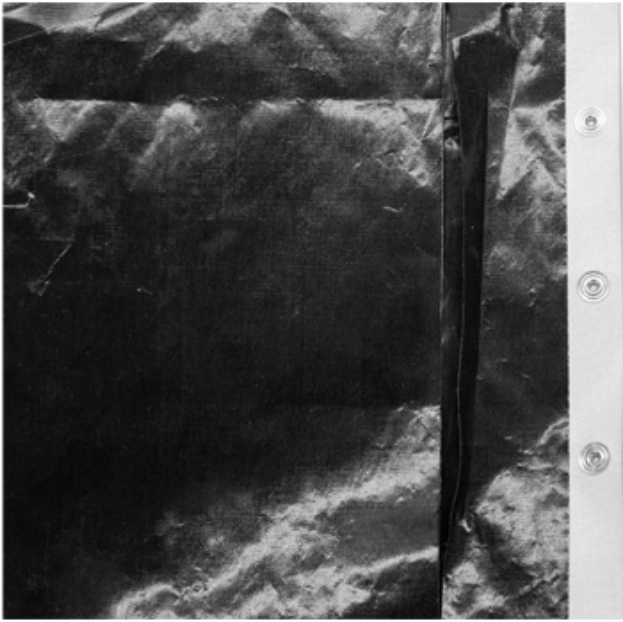
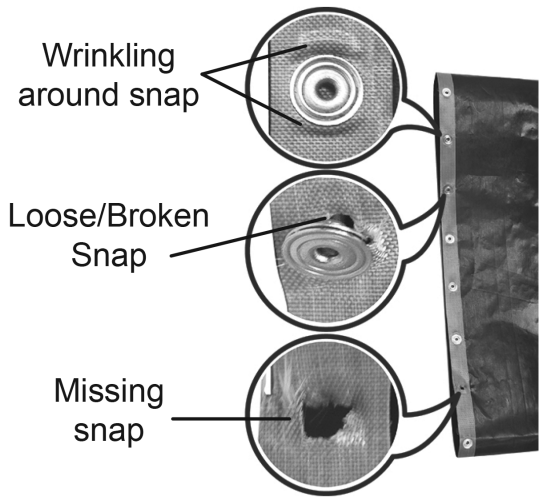

Figure 8. Close and Lock the Side Panel



**BELT IS TORN AND FOLDED.
REPLACE BELT.**

Figure 9. Example of Damaged Belt



Belt is wrinkling/distressed around snaps, has loose/damaged snaps, and is missing snaps. Replace defective belt.

Figure 10. Example of Damaged Belt



**BELT IS MISSING SNAPS
AND IS DAMAGED. REPLACE BELT.**

Figure 11. Example of Damaged Belt



**BELT IS TORN IN THE CENTER.
REPLACE BELT.**

Figure 12. Example of Damaged Belt

Troubleshooting

Problem	Possible Cause	Corrective Action
Control Display flashes PLt continuously. Product not toasting properly.	Platen temperature is below 545°F (285°C).	Allow the unit to warm up for 30 minutes and then recheck. If the Control Display still flashes PLt , contact your maintenance person or Antunes Technical Service for service.
	Failed Platen Thermocouple.	Contact your maintenance person or Antunes Technical Service for service.
	Failed Control Board	
Control Display flashes Er 10 continuously.	Control Compartment ambient temperature is above 150°F (66°C)	Verify side vents on toaster are unblocked and not near other heating appliances. If problem persists, contact your maintenance person or Antunes Technical Service for service.
	Failed Cooling Fan.	
	Failed Control Board	
Control Display Flashes SSr continuously. Product Burns.	Failed Front Platen Solid State Relay.	Contact your maintenance person or Antunes Technical Service for service.
	Failed Control Board.	
	Failed Front Platen Thermocouple.	
Control Display flashes Er 12 continuously. Product not toasting properly.	Loose Platen Thermocouple connection on Control Board or the Platen Thermocouple is open.	Re-secure the Platen Thermocouple to the Control Board. If the Control Display still reads Er 11 , check the Thermocouple for continuity. Contact your maintenance person or Antunes Technical Service for service.
	Failed Control Board.	
Control Display flashes Er 11 continuously. Product not toasting properly.	Shorted Platen Thermocouple to ground.	Disconnect and re-secure the Platen Thermocouple connection to the Control Board. If the Control Display still reads Er 10 , check the Thermocouple for continuity. Contact your maintenance person or Antunes Technical Service for service.
	Failed Control Board	
Control Display flashes StoP .	Mechanical bind in one or both conveyors.	Enter "user mode" to check the motor speed. Check both conveyors for mechanical binds. Test the motor. Replace necessary parts. Contact your maintenance person or Antunes Technical Service for service.
	Worn or damaged Ball Bearings.	
	Drive chain or sprockets damaged.	
	Failed Motor.	
	Failed Control Board.	
Control Display flashes SpEd .	Mechanical bind in one or both conveyors.	Enter "user mode" to check motor speed. Check both conveyors for mechanical binds. Replace necessary parts. Contact your maintenance person or Antunes Technical Service for service.
	Worn or damaged Ball Bearings.	
	Conveyor chains loose or damaged.	
	Drive chain or sprockets damaged.	
Crowns and/or Heels must be forced into the toaster. Product sticking and burning.	Belts are dirty, worn, or damaged (replace every 2-4 months).	Clean or replace Belts as described in the Maintenance section of this manual.
	Product does not meet specifications.	Contact your product supplier.
	One of the Conveyor shafts is stuck in the lower lock position.	Inspect positions of the shafts as described in the Maintenance section of this manual.
	Either both Upper/Lower Conveyor locks are not properly locked in place.	Inspect the proper position of the locks as described in the Maintenance section of this manual.
	Product does not meet specifications.	Contact your product supplier.
	Motor settings are incorrect.	Verify that the motor setting is set to 4000 as described in the Programming section of this Manual.
Side door will not close.	Either both Upper/Lower Conveyor Locks are not properly locked in place.	Inspect the proper position of the locks as described in the Maintenance section of this manual.
	The lock on the Side Door is in the locked position when trying to close the door.	Turn the lock to the unlocked position before closing the door.

Problem	Possible Cause	Corrective Action
Fan is making an unusual sound.	Failed Cooling Fan.	Verify vents on toaster are unblocked and not near other heating appliances. Clean fans as described in the Maintenance section of this manual. If problem persists, contact your maintenance person or Antunes Technical Service for service.
	Cooling Fan is dirty and needs to be cleaned.	
Control Display flashes HL continuously. Product is not toasting properly.	Hi-Limit Control is tripped.	Allow the unit to cool and reset the Hi-Limit Control. If it trips again, contact your maintenance person or Antunes Technical Service for service.
Control Display is blank.	Power Cord is not plugged in.	Plug the Power Cord into the appropriate outlet. Turn the toaster on. If the Control Display is still blank, contact your maintenance person or Antunes Technical Service for service.
	Circuit Breakers turned off or tripped. Damaged electrical outlet, plug, or Power Cord. Power Switch damaged.	Reset Circuit Breakers. If they trip again, check the Power Cord, Plug, and outlet for damage. Contact your maintenance person and Electrician for service.
	Faulty Transformer.	Replace Transformer.
Conveyors not turning.	Belt is damaged.	Replace Belts
	Motor Drive Chain is detached from sprockets.	Reinstall the Drive Chain.
	Failed Drive Motor.	Contact your maintenance person or Antunes Technical Service for service.
Belts are ripped or torn.	Rollers or Heater Cover Plates are dirty and need to be cleaned.	Clean Rollers and Heater Cover Plates as outlined in the Maintenance section of this manual.
	Belts are not installed properly.	Install Belts correctly as outlined in the Maintenance section of this manual.
	Roller(s) in the incorrect locked position during operation.	Unlock Rollers to operational position.
	Front Conveyor Lock is disengaged.	Engage and lock the Front Conveyor Lock.

Replacement Parts

ITEM	PART NO.	DESCRIPTION	QTY
1	0013093	Bracket Assy Top	1
2	0013094	Bracket Assy Bottom	1
3	0013095	Bearing Bracket Assy	2
4	0013111	Assembly Drive Chain Tensioner	1
5	0013338	Base Assy	1
6	0013346	Door Assy	1
7	0013509	Drive Motor Assy	1
8	0013666	Electronics Assy	1
9	0013817	Housing Assy	1
10	0021724	Weldment, Bearing Brkt & Spring Guide - RH	2
11	0021725	Weldment, Bearing Brkt & Spring Guide - LH	2
12	0021838	Weldment, Drive Roller Main Platten	2
13	0021839	Weldment, Idler Main Platen	1
14	0021897	End Housing Panel Wldmt	1
15	0022313	Control Housing Wldmt	1
16	0022314	Main Platen Frame Wldmt	1
17	0022324	Top Frame Wldmt	1
18	0022326	Cover Wldmt	1
19	0022332	Back Cover Wldmt	1
20	0022339	Insulation Plate Wldmt	2
21	0022759	Wldmt, Frame Locking Bracket	1
22	0022760	Wldmt, End Housing	1
23	0022773	Wldmt, Idler Bearing	1
24	0022796	Assy, Platen Lock RH	1
25	0022797	Assy, Platen Lock LH	1
26	0022968	Chute Wldmt, Flatbread	1
27	0100292	Platen, Main 230V, 2300W	2
28	0200384	Gasket, Base - 21.64" LG	2
29	0200385	Gasket, Base - 19.7" LG	2
30	0400119	Bushing, Shorty 5/8	1
31	0400138	Conduit Locknut 1/2"	1
32	0400347	Strain Relief - Cord Connector	1
33	0400432	Bushing, Open/Closed	1
34	0400480	Insulation, Platen	2
35	0504083	Hi-Limit Guard	2
36	0506543	Plate, Tensioner LH	1
37	0506566	Plate, Tensioner	2
38	0506959	Retainer, Bearing	2
39	0507551	Base Bottom Side	1
40	0507552	Bun Stop	1
41	0507554	Electrical Cover	1
42	0507581	Plate, Air Cover	1
43	0507585	Plate, Insulation	2
44	0508065	Chute, Front	1
45	0508220	Plate, Tensioner RH	1
46	0508553	Cover, Fan	1
47	0600141	Spring, Compression	4
48	0600155	Spring, Compression Setting	1
49	0700588	Power Cord HRMN/IEC-309	1
50	0701052	Wire Set, GST-1H Main	1
51	0701053	Wire Set, GST-1H Platen	1
52	0701054	Wire Set, GST-1H	1
53	0701055	Wire Set, GST-1H XFMR	1
54	0701056	Braided Wire Set	1
55	0800438	Rod Spacer	4
56	1001658	Label, Control	1
57	2000259	Tube, 1/4"	4
58	2100212	Handle, Pocket Pull, Snap-In	2
59	2100334	Thrust Strip, Teflon, 2.140 X 1	4

ITEM	PART NO.	DESCRIPTION	QTY
60	2110199	Kwik-Klip, Type "C"	1
61	2140101	Adhesive / Sealant - RTV	1
62	2152061	Sprocket ,25B14 1/2 Bore	4
63	2150187	Chain, Drive	1
64	2150258	Bearing, Idler	2
65	2150384	Bearing Assy, High Temp 1 1/8" OD X 1/2" ID	8
66	2150444	Thrust Bearing .500" ID	8
67	2180514	Clamp, Cable	3
68	3000124	Ring, Retainer	2
69	3040105	Nut, Hex 'Keps' #4-40 Zinc	4
70	3060130	Nut ,Hex "Keps" #06-32 Steel; Zinc Plated	3
71	3080124	8-32 x .5 LG Round HD. One-Way	1
72	3080145	Nut, Hex Acorn #08-32 Low Crown	4
73	3080157	Screw, Tap 8-32 X 3/8" LG	30
74	3080193	Scr. Mach #8-32 X 1 1/4" SLTFLTHD	2
75	3080199	Nut, Hex Keps #8-32 S/S	4
76	3080202	Nut, Hex Tri-Lock #8-32	8
77	3080203	Screw #8-32 x 3/8 With Int. Tooth Washer	14
78	3100102	Washer, Int. Tooth-Lock,#10	8
79	3100110	Screw, Mach. #10-32 X 1/2"	4
80	3100146	Nut, Hex "Keps" #10-32	26
81	3100196	Bolt, Shdr 1/4 DIA X 1/8, 10-32 S.S.	2
82	3100199	SCR, #10-32 X 3/8 LG Socket HD Cap	12
83	3100204	Screw, FHPH, #10-32 X 1/4 LG	2
84	3250103	Screw, Hexcap 1/4 X 3/4"	3
85	3250104	Washer, Flat - 1/4"	10
86	3250109	Screw, Hexcap 1/4-20 X 1/2"	7
87	3250154	Washer, Ø1/4" Helical Spring Lock	10
88	3250177	Screw, Shoulder	1
89	3250180	Washer Flat, .468 OD X .255 ID X .029 THK	1
90	3100225	Set Screw, Cone Point, 10-32 UNF-2A X 1/4"	4
91	3250217	Bolt, Shoulder .313 SD X 1.125 SL	8
92	3250220	1/4"-20 Nylon Insert Locknut	2
93	4000211	Fan, Axial 230V	1
94	4010221	CAP-MP, Motor Run	1
96	4030332	Thermostat, Hi-Limit	2
97	4050214	Thermocouple, Type K, Ø3/16", Closed End, 25" LG	2
98	4060374	Grounding Lug	1
99	4060377	Cable Tie Mount W/ Adhesive	4
100	4060398	Terminal Block, S-Series	1
101	4070280	Assy-PCB, Tortilla Toaster	1
102	5206035	Sleeve, Elec - Fiberglass	1
103	7001659	2PK Full Belt, Main Belt	1

* Item available in packages of ten (10).

Exploded Diagram #1

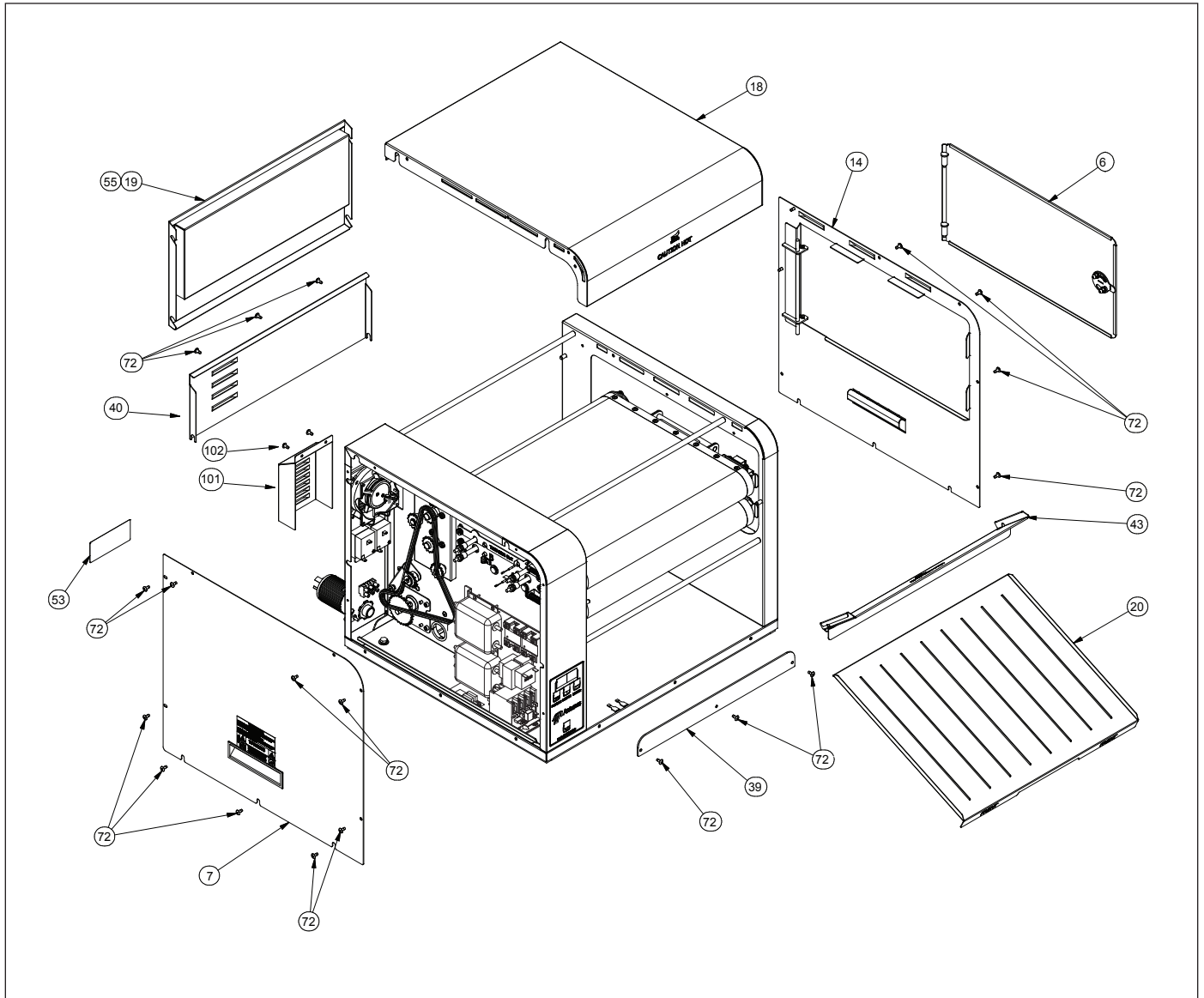

Exploded Diagram #2

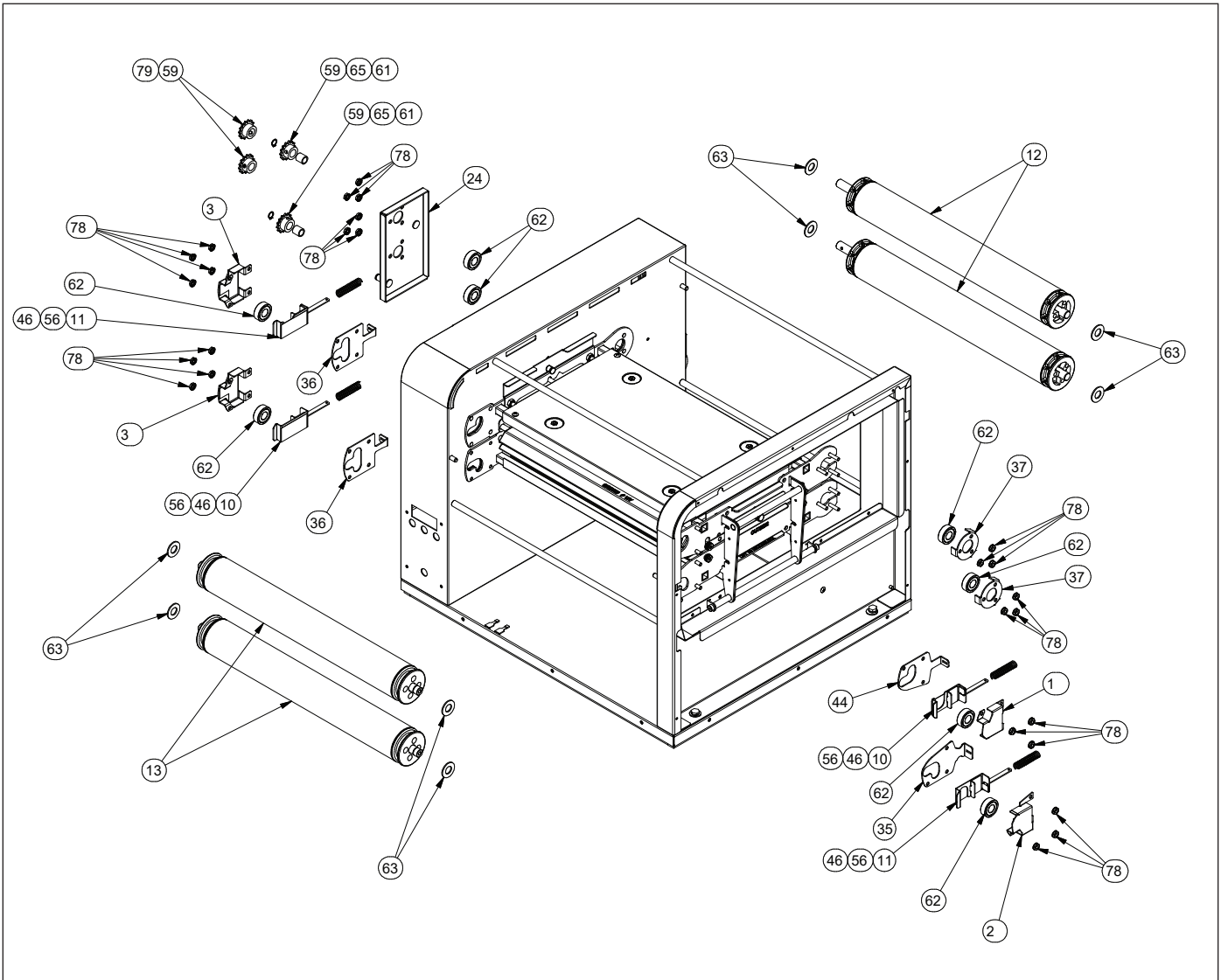

Exploded Diagram #3

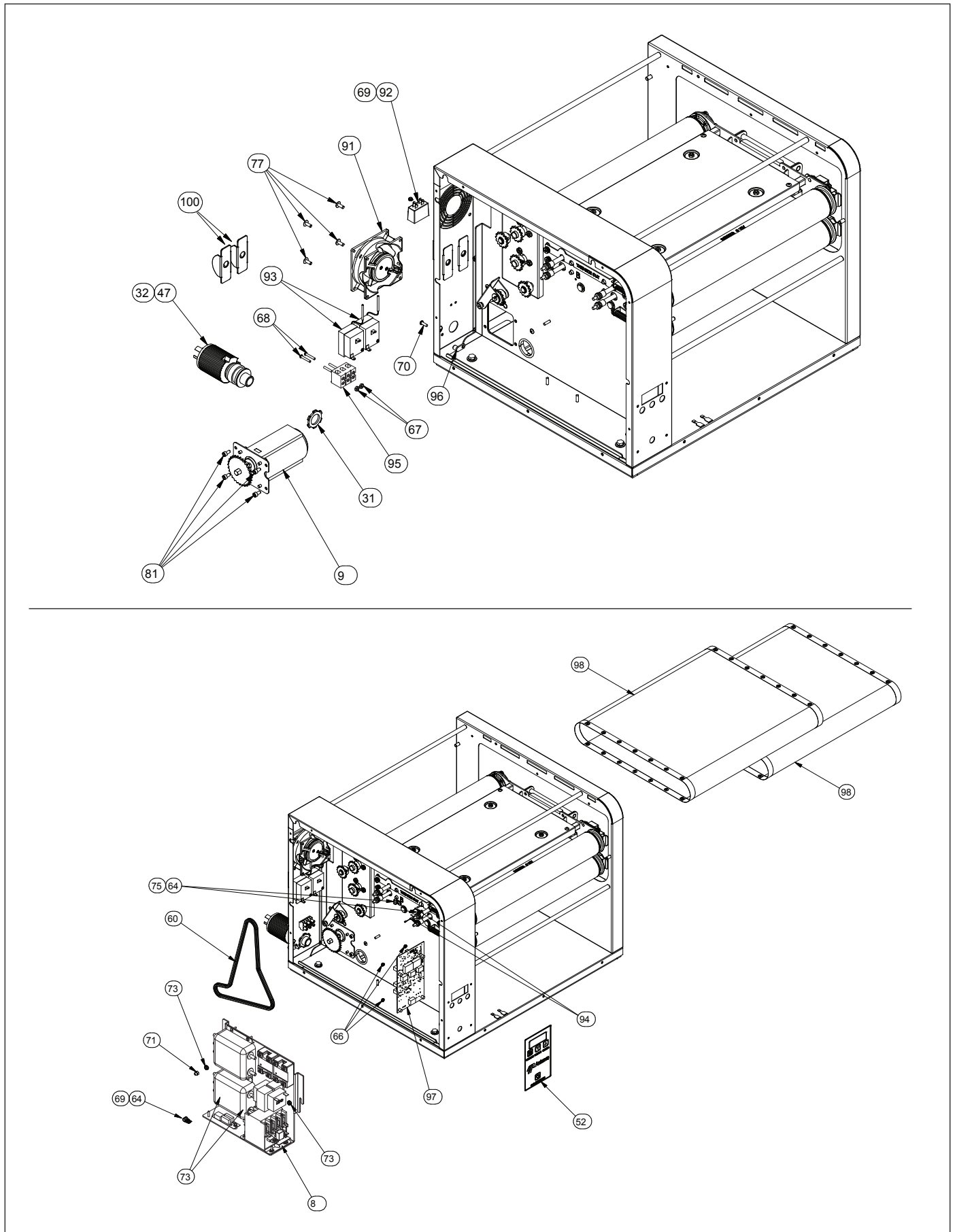

Exploded Diagram #4

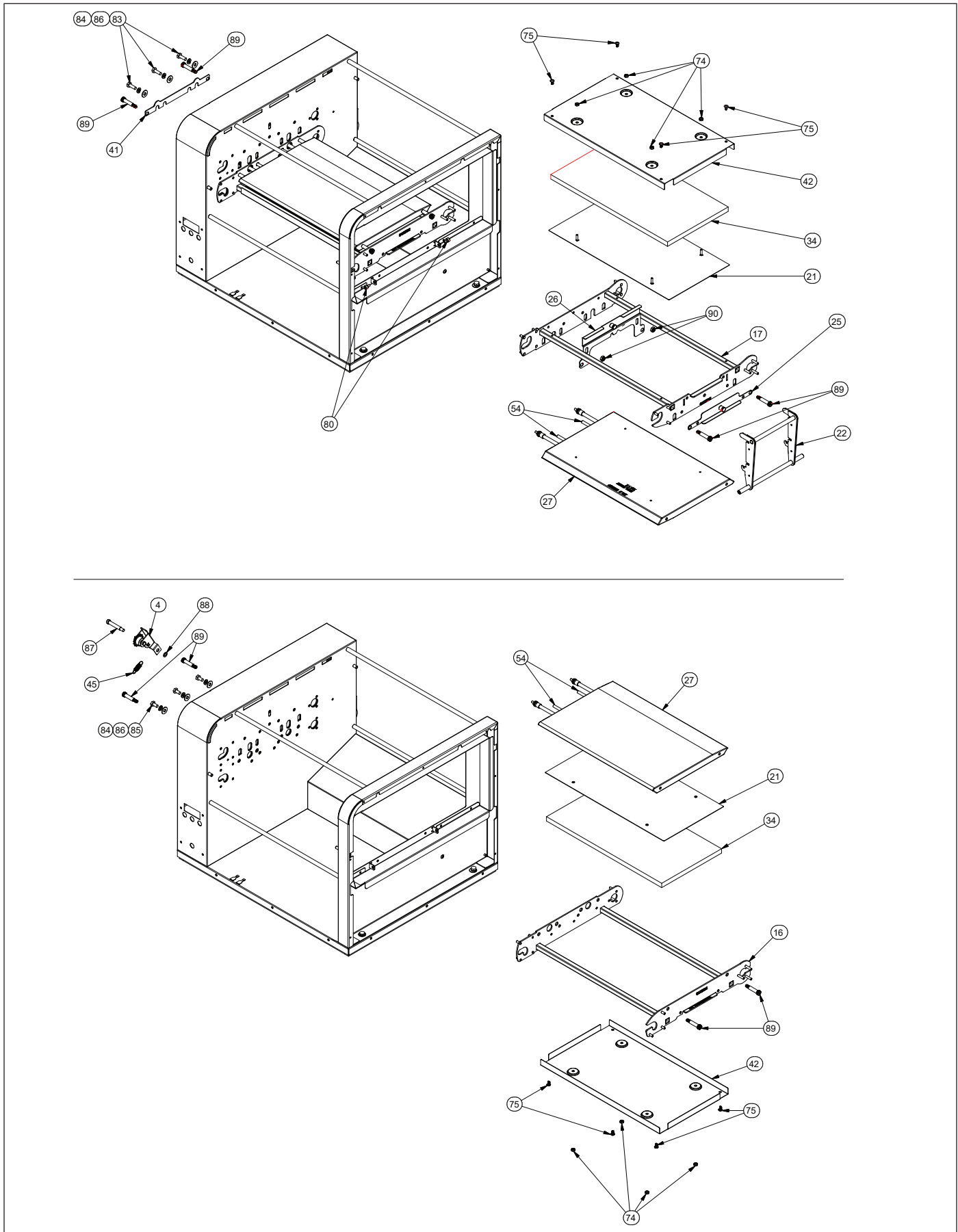

Exploded Diagram #5

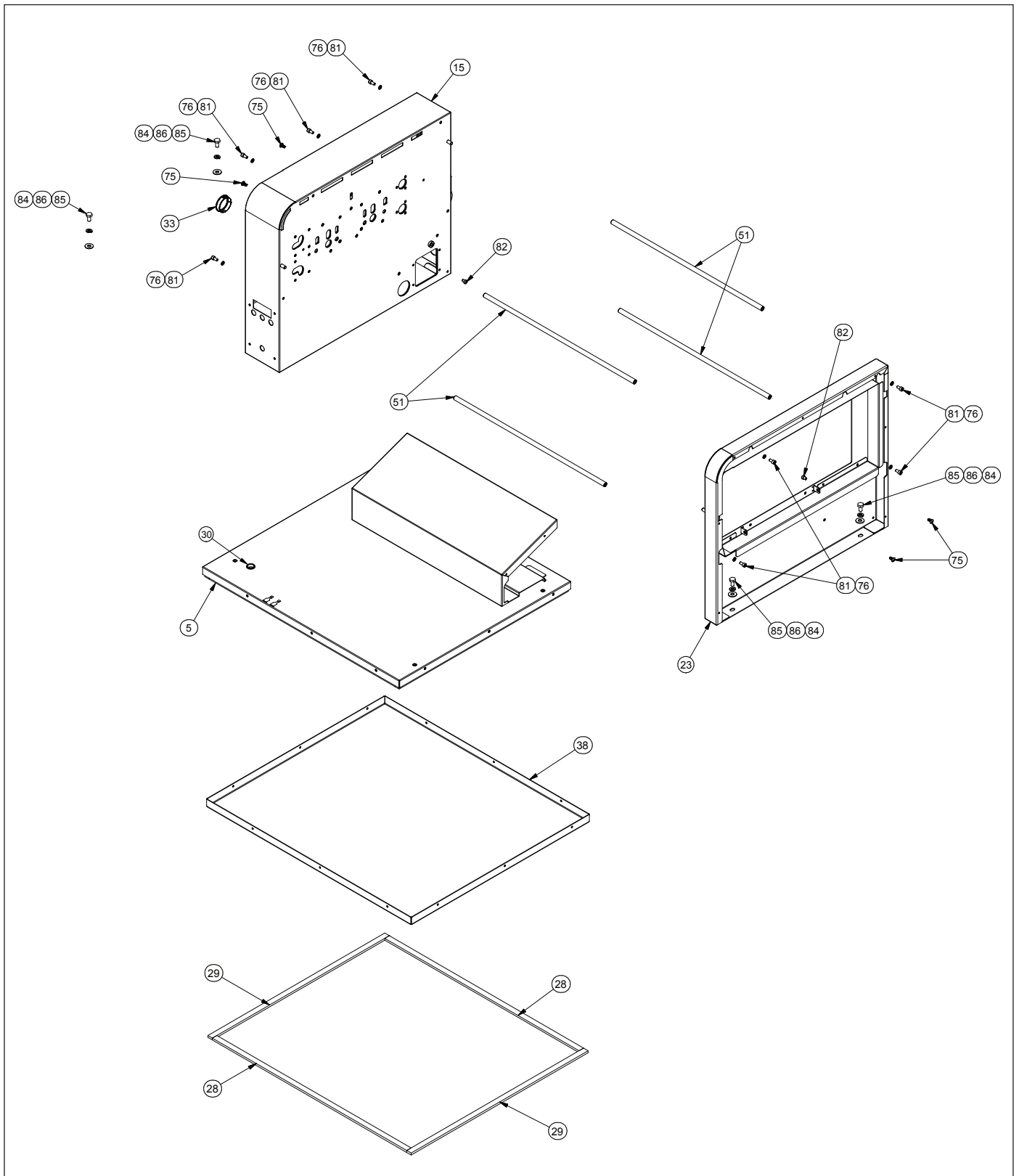

Wiring Diagram

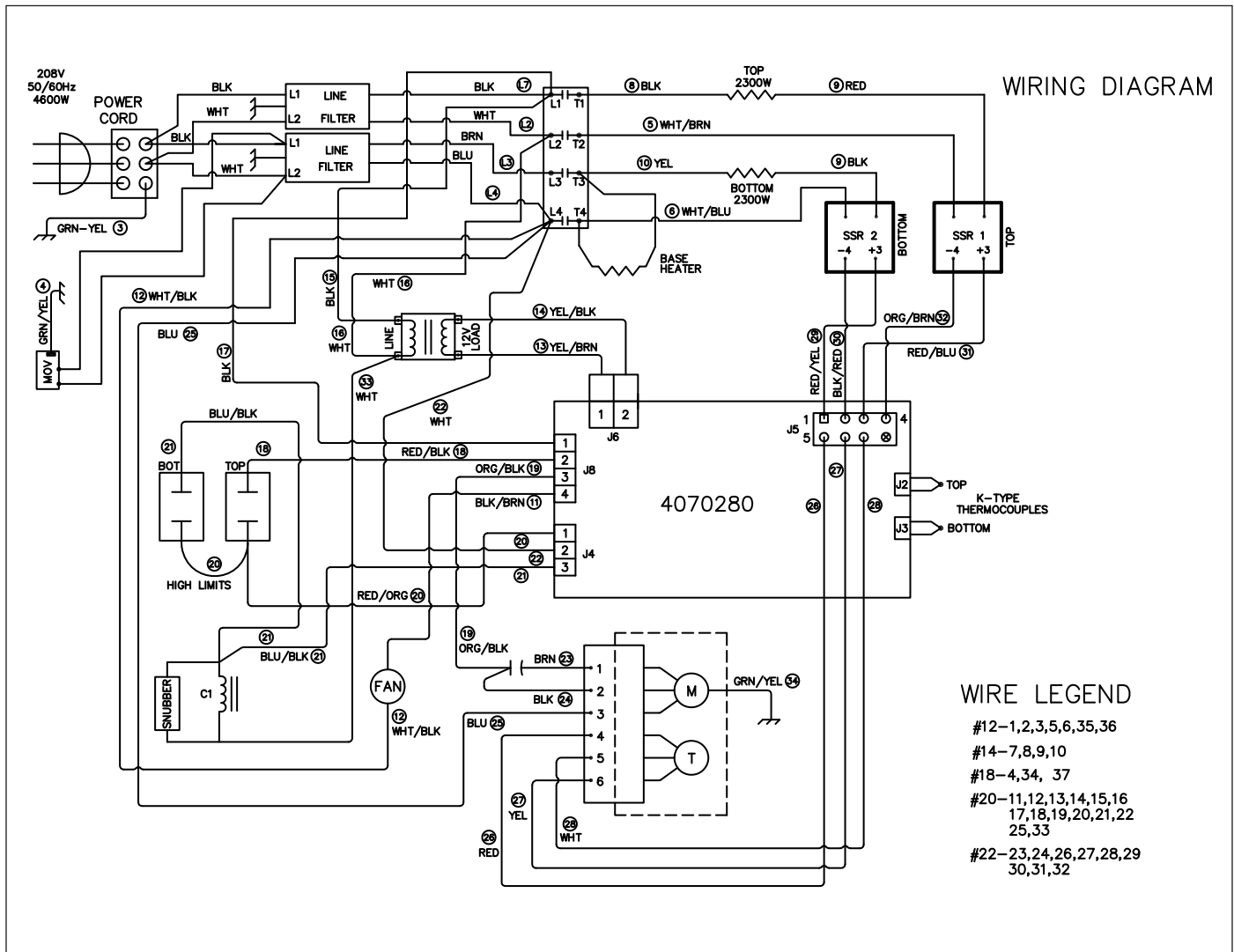

Limited Warranty

Equipment manufactured by Antunes (Antunes) has been constructed of the finest materials available and manufactured to high quality standards. These units are warranted to be free from electrical and mechanical defects for a period of one (1) year from date of purchase under normal use and service, and when installed in accordance with manufacturer's recommendations. To insure continued operation of the units, follow the maintenance procedures outlined in the Owner's Manual. During the first 12 months, electro-mechanical parts, non-overtime labor, and travel expenses up to 2 hours (100 miles/160 km), round trip from the nearest Authorized Service Center are covered.

1. This warranty does not cover cost of installation, defects caused by improper storage or handling prior to placing of the Equipment. This warranty does not cover overtime charges or work done by unauthorized service agencies or personnel. This warranty does not cover normal maintenance, calibration, or regular adjustments as specified in operating and maintenance instructions of this manual, and/or labor involved in moving adjacent objects to gain access to the equipment. This warranty does not cover consumable/wear items. This warranty does not cover damage to the Load Cell or Load Cell Assembly due to abuse, misuse, dropping of unit/shock loads or exceeding maximum weight capacity (4 lbs). This warranty does not cover water contamination problems such as foreign material in water lines or inside solenoid valves. It does not cover water pressure problems or failures resulting from improper/incorrect voltage supply. This warranty does not cover Travel Time & Mileage in excess of 2 hours (100 miles/160 km) round trip from the nearest authorized service agency.
2. Antunes reserves the right to make changes in design or add any improvements on any product. The right is always reserved to modify equipment because of factors beyond our control and government regulations. Changes to update equipment do not constitute a warranty charge.
3. If shipment is damaged in transit, the purchaser should make a claim directly upon the carrier. Careful inspection should be made of the shipment as soon as it arrives and visible damage should be noted upon the carrier's receipt. Damage should be reported to the carrier. This damage is not covered under this warranty.
4. Warranty charges do not include freight or foreign, excise, municipal or other sales or use taxes. All such freight and taxes are the responsibility of the purchaser.
5. THIS WARRANTY IS EXCLUSIVE AND IS IN LIEU OF ALL OTHER WARRANTIES, EXPRESSED OR IMPLIED, INCLUDING ANY IMPLIED WARRANTY OR MERCHANTABILITY OR FITNESS FOR A PARTICULAR PURPOSE, EACH OF WHICH IS HEREBY EXPRESSLY DISCLAIMED. THE REMEDIES DESCRIBED ABOVE ARE EXCLUSIVE AND IN NO EVENT SHALL ANTUNES BE LIABLE FOR SPECIAL CONSEQUENTIAL OR INCIDENTAL DAMAGES FOR THE BREACH OR DELAY IN PERFORMANCE OF THIS WARRANTY.



Corporate Headquarters
Carol Stream, IL, USA
Phone: +1.630.784.1000
Toll Free: +1.800.253.2991
Fax: +1.(630).784-1650

China Facility
Suzhou, China
Phone: +84.512.6841.3637
Fax: +86.512.6841.3907

India Facility
Chennai, India
Phone: +91.44.25532212
Fax: +91.44.25532415